



### General Description

AF1205 consists of step-down switching regulator with PWM control. These devices include a reference voltage source, oscillation circuit, error amplifier, internal PMOS and etc.

AF1205 provides low-ripple power, high efficiency, and excellent transient characteristics. The PWM control circuit is able to vary the duty ratio linearly from 0 up to 100%. This converter also contains an error amplifier circuit as well as a soft-start circuit that prevents overshoot at startup. An enable function, an over current protect function and a short circuit protect function are built inside, and when OCP or SCP happens, the operation frequency will be reduced from 300KHz to 60KHz. Also, an internal compensation block is built in to minimum external component count.

With the addition of an internal P-channel Power MOS, a coil, capacitors, and a diode connected externally, these ICs can function as step-down switching regulators. They serve as ideal power supply units for portable devices when coupled with the SOP-8P mini-package, providing such outstanding features as low current consumption. Since this converter can accommodate an input voltage up to 23V, it is also suitable for the operation via an AC adapter.

### Features

- Input voltage: 4.2V to 23V.
- Output voltage: 0.8V to VIN.
- Duty ratio: 0% to 100% PWM control
- Oscillation frequency: 300KHz typ.
- Soft-start, Current limit, Enable function
- Thermal Shutdown function
- Built-in internal P-channel MOS
- SOP-8P Package.

### Application

- PC Motherboard
- LCD Monitor
- Graphic Card
- DVD-Video Player
- Telecom Equipment
- ADSL Modem
- Printer and other Peripheral Equipment
- Microprocessor core supply
- Networking power supply

### Pin Define ( SOP-8P )

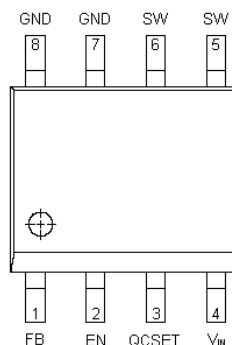

### Marking Information



### Typical Application Circuit

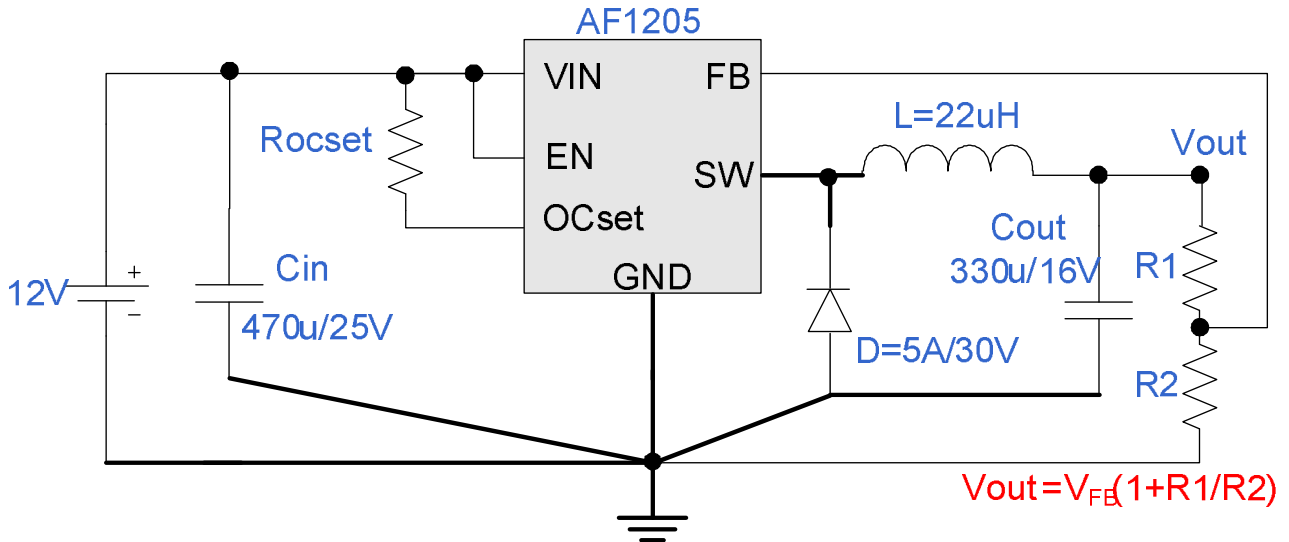

### Pin Description

Pin	Symbol	Description
FB	1	Feedback pin.
EN	2	Enable / Disable pin H: Normal operation mode. (Step-down operation) L: Shutdown mode. (All circuits deactivated)
OCSET	3	Add an external resistor to set max output current.
VIN	4	IC power supply pin
SW	5 · 6	Switch Pin. Connect external inductor/diode here. Minimize trace area at this pin to reduce EMI.
GND	7 · 8	GND Pin

### Ordering Information

Part Ordering No.	Part Marking	Package	Unit	Quantity
AF1205S8RG	AF1205	SOP-8P	Tape & Reel	2500 EA

- ※ A Lot code
- ※ B Date code
- ※ AF1205S8RG : 13" Tape & Reel ; Pb- Free ; Halogen- Free

### Block Diagram

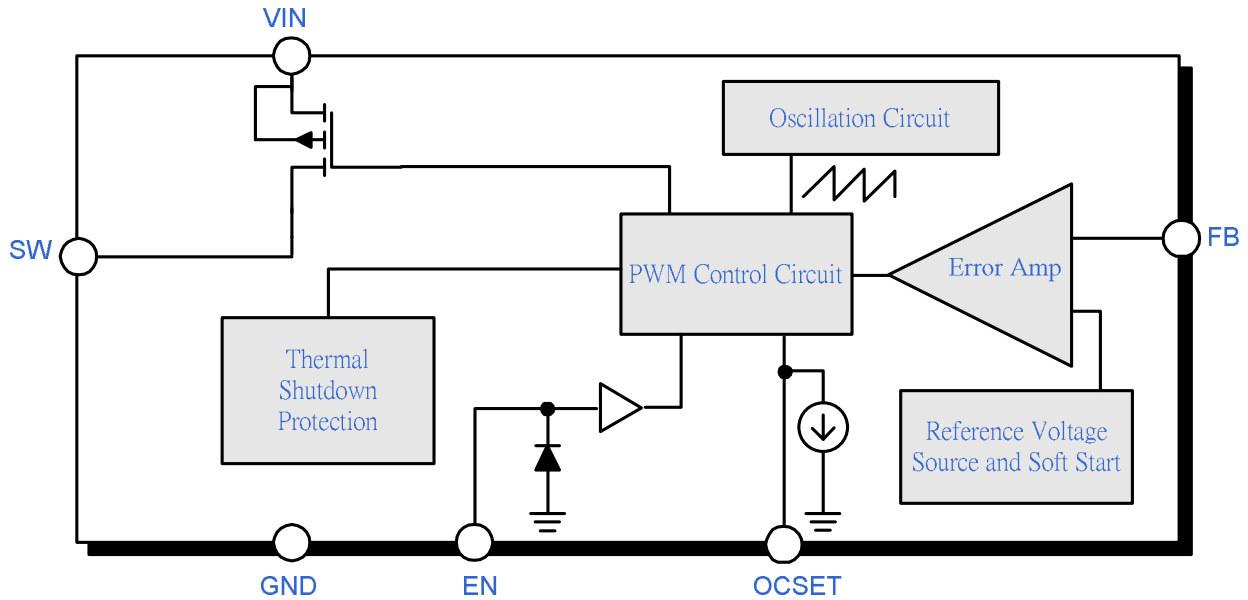

**Absolute Maximum Ratings** ( $T_A=25^{\circ}\text{C}$  Unless otherwise noted)

The following ratings designate persistent limits beyond which damage to the device may occur.

Symbol	Parameter	Value	Unit
$V_{IN}^{(1)}$	$V_{IN}$ Pin Voltage	$V_{SS} - 0.3$ to $V_{SS} + 25$	V
$V_{FB}$	Feedback Pin Voltage	$V_{SS} - 0.3$ to $V_{CC}$	V
$V_{ON/OFF}^{(1)}$	ON/OFF Pin Voltage	$V_{SS} - 0.3$ to $V_{IN} + 0.3$	V
$V_{OUTPUT}$	Switch Pin Voltage	$V_{SS} - 0.3$ to $V_{IN} + 0.3$	V
$P_D$	Power Dissipation	Internally limited	mW
$T_{OPR}$	Operating Temperature Range	-20 to +125	$^{\circ}\text{C}$
$T_{STG}$	Storage Temperature Range	-40 to +150	$^{\circ}\text{C}$

**Caution:**

The absolute maximum ratings are rated values exceeding which the product could suffer physical damage. These values must therefore not be exceeded under any conditions.



### Electrical Characteristics

( $T_A=25^{\circ}\text{C}$ ,  $V_{CC}=12\text{V}$ , unless otherwise specified.)

Symbol	Parameter	Conditions	Min.	Typ.	Max.	Unit
$V_{IN}$	Input Voltage		4.2		23	V
$V_{FB}$	Feedback Voltage	$I_{OUT}=0.1\text{A}$	0.784	0.8	0.816	V
$I_{FB}$	Feedback Bias Current	$I_{OUT}=0.1\text{A}$		0.1	0.5	$\mu\text{A}$
$I_{SW}$	Switch Current		5		-	A
$I_{GND}$	Current Consumption During Power Off	$V_{ON/OFF}=0\text{V}$		1	10	$\mu\text{A}$
$I_{OCSET}$	OCSET Pin Bias Current		75	90	105	$\mu\text{A}$
$\frac{\Delta V_{OUT}}{V_{OUT}}$	Line Regulation	$V_{IN}=5\text{V}\sim 23\text{V}$		1	2	%
$\frac{\Delta V_{OUT}}{V_{OUT}}$	Load Regulation	$I_{OUT}=0.1$ to 4A		0.2	0.5	%
$f_{OSC}$	Oscillation Frequency	Measure waveform at SW pin	240	300	360	KHz
$f_{OSC1}$	Frequency of Current Limit or Short Circuit Protect	Measure waveform at SW pin	30	60	90	KHz
$V_{SH}$	EN Pin Input Voltage	Evaluate oscillation at SW pin	2.0			V
$V_{SL}$		Evaluate oscillation stop at SW pin			0.8	
$I_{SH}$	EN Pin Input Leakage Current			20	-	$\mu\text{A}$
$I_{SL}$				-10	-	$\mu\text{A}$
$T_{SS}$	Soft-Start Time		0.3	2	5	ms
$R_{DS(on)}$	Internal MOSFET $R_{dson}$	$V_{IN}=5\text{V}$ , $V_{FB}=0\text{V}$		110	150	m $\Omega$
		$V_{IN}=12\text{V}$ , $V_{FB}=0\text{V}$		60	80	
$\eta$	Efficiency	$V_{IN}=12\text{V}$ , $V_{OUT}=5\text{V}$ $I_{OUT}=4\text{A}$		87		%



## **Function Description**

### **PWM Control**

The AF1205 consists of DC/DC converters that employ a pulse-width modulation (PWM) system.

In converters of the AF1205, the pulse width varies in a range from 0 to 100%, according to the load current. The ripple voltage produced by the switching can easily be removed through a filter because the switching frequency remains constant. Therefore, these converters provide a low-ripple power over broad ranges of input voltage and load current.

### **RDS(ON) Current Limiting**

The current limit threshold is setting by the external resistor connecting from VIN supply to OCSET. The internal 100uA sink current crossing the resistor sets the voltage at the pin of OCSET. When the PWM voltage is less than the voltage at OCSET, an over-current condition is triggered.



**Package Information ( SOP-8P )**

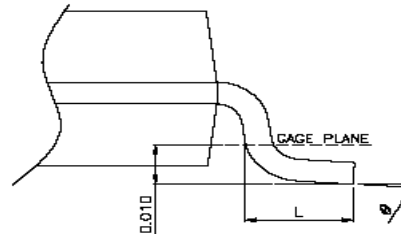
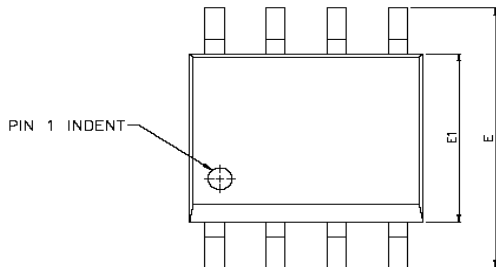

DETAIL A

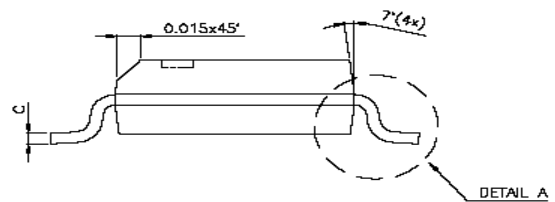
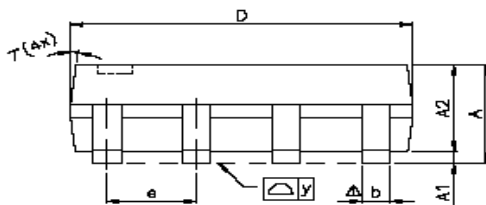

DETAIL A

SYMBOLS	DIMENSIONS IN MILLIMETERS			DIMENSIONS IN INCHES		
	MIN	NOM	MAX	MIN	NOM	MAX
A	1.47	1.60	1.73	0.058	0.063	0.068
A1	0.10	—	0.25	0.004	—	0.010
A2	—	1.45	—	—	0.057	—
b	0.33	0.41	0.51	0.013	0.016	0.020
C	0.19	0.20	0.25	0.0075	0.008	0.0098
D	4.80	4.85	4.95	0.189	0.191	0.195
E	5.80	6.00	6.20	0.228	0.236	0.244
E1	3.80	3.90	4.00	0.150	0.154	0.157
e	—	1.27	—	—	0.050	—
L	0.38	0.71	1.27	0.015	0.028	0.050
$\Delta$ y	—	—	0.076	—	—	0.003
$\theta$	0°	—	8°	0°	—	8°

©2010 Alfa-MOS Technology Corp.  
 2F, No.80, Sec.1, Cheng Kung Rd., Nan Kang Dist., Taipei City 115, Taiwan (R.O.C.)  
 Tel : 886 2) 2651 3928  
 Fax : 886 2) 2786 8483  
 ©http://www.alfa-mos.com