



General Description

AF1210 consists of step-down switching regulator with PWM control. These devices include a reference voltage source, oscillation circuit, error amplifier, internal PMOS and etc.

AF1210 provides low-ripple power, high efficiency, and excellent transient characteristics. The PWM control circuit is able to vary the duty ratio linearly from 0 up to 100%. This converter also contains an error amplifier circuit as well as a soft-start circuit that prevents overshoot at startup. An enable function, an over current protect function and a short circuit protect function are built inside, and when OCP or SCP happens, the operation frequency will be reduced from 150KHz to 30KHz. Also, an internal compensation block is built in to minimum external component count.

With the addition of an internal P-channel Power MOS, a coil, capacitors, and a diode connected externally, these ICs can function as step-down switching regulators. They serve as ideal power supply units for portable devices when coupled with the SOP-8P mini-package, providing such outstanding features as low current consumption. Since this converter can accommodate an input voltage up to 40V, it is also suitable for the operation via an AC adapter.

Features

- Input voltage: 4.2V to 40V.
- Output voltage: 0.8V to V_{IN} .
- Duty ratio: 0% to 100% PWM control
- Oscillation frequency: 150KHz typ.
- Soft-start, Current limit, Enable function
- Thermal Shutdown function
- Built-in internal P-channel MOS
- SOP-8P Package.

Application

- PC Motherboard
- LCD Monitor
- Graphic Card
- DVD-Video Player
- Telecom Equipment
- ADSL Modem
- Printer and other Peripheral Equipment
- Microprocessor core supply
- Networking power supply

Pin Define (SOP-8P)

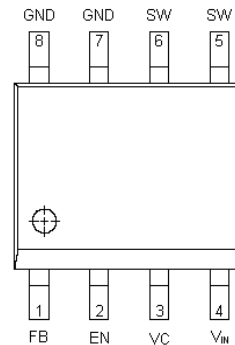

Marking Information

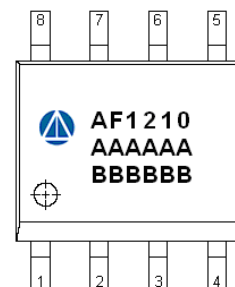



Typical Application Circuit

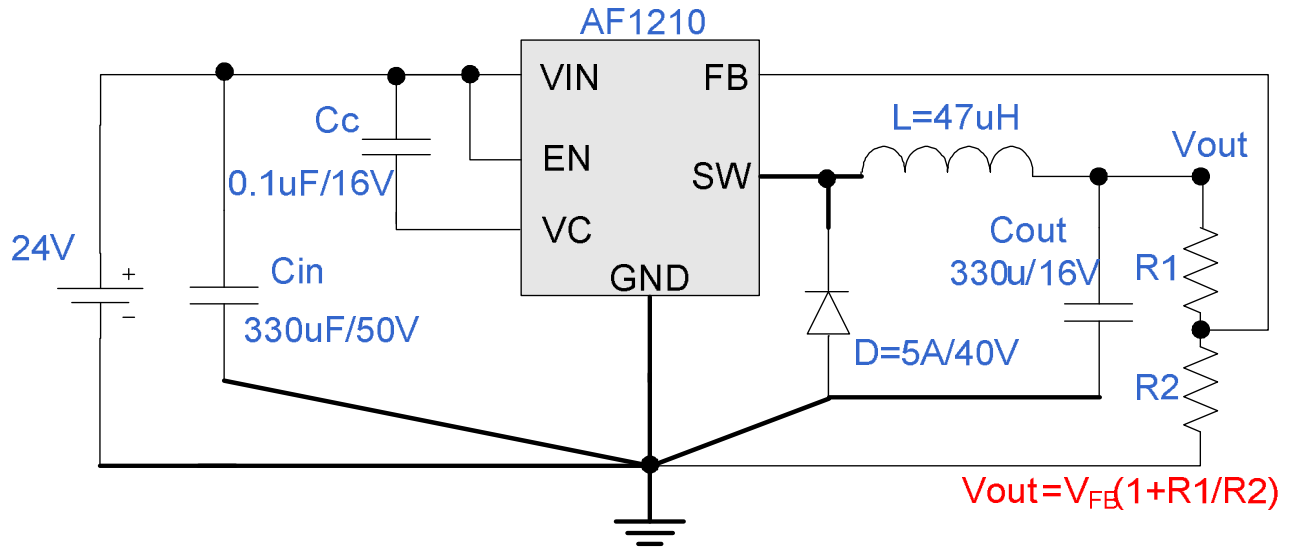

Pin Description

Pin	Symbol	Description
FB	1	Feedback pin.
EN	2	Enable / Disable pin H: Normal operation mode. (Step-down operation) L: Shutdown mode. (All circuits deactivated)
VC	3	Add an external capacitor to VIN. It's voltage is set to VIN -7V
VIN	4	IC power supply pin
SW	5 · 6	Switch Pin. Connect external inductor/diode here. Minimize trace area at this pin to reduce EMI.
GND	7 · 8	GND Pin

Ordering Information

Part Ordering No.	Part Marking	Package	Unit	Quantity
AF1210S8RG	AF1210	SOP-8P	Tape & Reel	2500 EA

- ※ A Lot code
- ※ B Date code
- ※ AF1210S8RG : 13" Tape & Reel ; Pb- Free ; Halogen- Free



Block Diagram

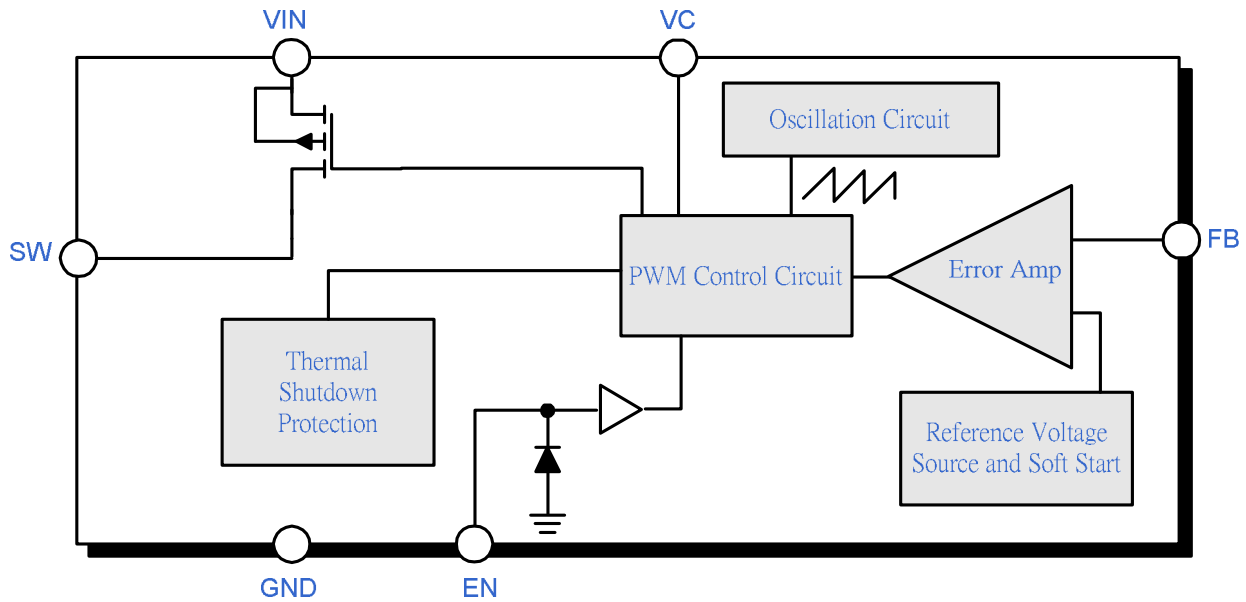

Absolute Maximum Ratings ($T_A=25^\circ\text{C}$ Unless otherwise noted)

The following ratings designate persistent limits beyond which damage to the device may occur.

Symbol	Parameter	Value	Unit
V_{IN}	VIN Pin Voltage	GND - 0.3 to GND + 40	V
V_{FB}	Feedback Pin Voltage	GND - 0.3 to V_{IN}	V
V_{EN}	EN Pin Voltage	GND - 0.3 to $V_{IN} + 0.3$	V
V_{SW}	Switch Pin Voltage	GND - 0.3 to $V_{IN} + 0.3$	V
V_C	Clamp Voltage	$V_{IN} - 20$ to $V_{IN} + 0.3$	V
P_D	Power Dissipation	Internally limited	mW
T_{OPR}	Operating Temperature Range	-20 to +125	$^\circ\text{C}$

Caution:

The absolute maximum ratings are rated values exceeding which the product could suffer physical damage. These values must therefore not be exceeded under any conditions.



Electrical Characteristics

($T_A=25^{\circ}\text{C}$, $V_{IN}=24\text{V}$, unless otherwise specified.)

Symbol	Parameter	Conditions	Min.	Typ.	Max.	Unit
V_{IN}	Input Voltage		4.2		40	V
V_{EN_H}	EN Pin Input Voltage	Evaluate oscillation at SW pin	2.0			V
V_{EN_L}		Evaluate oscillation stop at SW pin	-		0.8	
V_{FB}	Feedback Voltage	$I_{OUT}=0.1\text{A}$	0.803	0.82	0.836	V
I_{FB}	Feedback Bias Current	$I_{OUT}=0.1\text{A}$	-	0.1	0.5	μA
I_{CL}	Current Limit		2	2.75	3.5	A
I_{GND}	Quiescent Current (switch off)	$EN \geq VEN_H$, $V_{FB} = 1\text{V}$		1	2	mA
I_{GND_OFF}	Current Consumption During Power Off	$EN \leq VEN_L$		1	10	μA
V_C	Voltage Clamp	No load	VIN-6	VIN-7	VIN-8	V
F_{OSC}	Oscillation Frequency	Measure waveform at SW pin	120	150	180	KHz
F_{OSC1}	Frequency of Current Limit or Short Circuit Protect	Measure waveform at SW pin	20	30	40	KHz
$\frac{\Delta V_{OUT}}{V_{OUT}}$	Line Regulation	$V_{IN}=12\text{V}\sim 40\text{V}$, $I_{OUT}=0.2\text{A}$		1	2	%
$\frac{\Delta V_{OUT}}{V_{OUT}}$	Load Regulation	$I_{OUT}=0.1$ to 2A		0.2	0.5	%
$R_{DS(ON)}$	Internal MOSFET Rdson	$V_{FB}=0\text{V}$, $I_{OUT}=1\text{A}$		80	100	m Ω
η	Efficiency	$V_{IN}=24\text{V}$, $V_{OUT} = 5\text{V}$, $I_{OUT}=2\text{A}$		87		%

Function Description

PWM Control

The AF1210 consists of DC/DC converters that employ a pulse-width modulation (PWM) system.

In converters of the AF1210, the pulse width varies in a range from 0 to 100%, according to the load current. The ripple voltage produced by the switching can easily be removed through a filter because the switching frequency remains constant. Therefore, these converters provide a low-ripple power over broad ranges of input voltage and load current.



Package Information (SOP-8P)

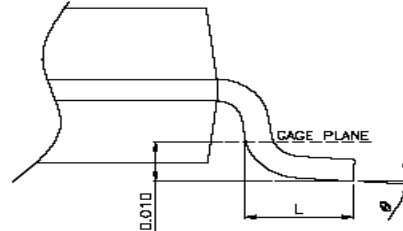
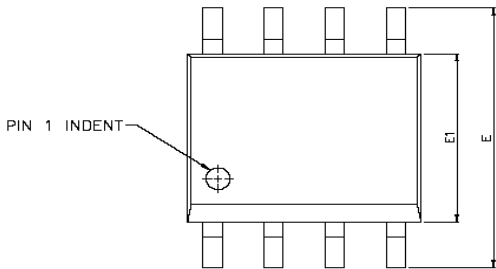

DETAIL A

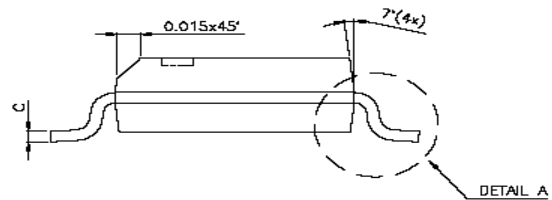
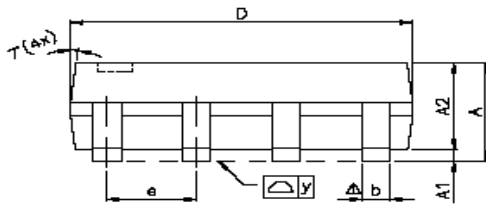

DETAIL A

SYMBOLS	DIMENSIONS IN MILLIMETERS			DIMENSIONS IN INCHES		
	MIN	NOM	MAX	MIN	NOM	MAX
A	1.47	1.60	1.73	0.058	0.063	0.068
A1	0.10	—	0.25	0.004	—	0.010
A2	—	1.45	—	—	0.057	—
b	0.33	0.41	0.51	0.013	0.016	0.020
C	0.19	0.20	0.25	0.0075	0.008	0.0098
D	4.80	4.85	4.95	0.189	0.191	0.195
E	5.80	6.00	6.20	0.228	0.236	0.244
E1	3.80	3.90	4.00	0.150	0.154	0.157
e	—	1.27	—	—	0.050	—
L	0.38	0.71	1.27	0.015	0.028	0.050
Δ y	—	—	0.076	—	—	0.003
θ	0°	—	8°	0°	—	8°

©2010 Alfa-MOS Technology Corp.
2F, No.80, Sec.1, Cheng Kung Rd., Nan Kang Dist., Taipei City 115, Taiwan (R.O.C.)
Tel : 886 2) 2651 3928
Fax : 886 2) 2786 8483
©http://www.alfa-mos.com