



General Description

AF1505 is a step down LED driver that is designed to meet least 2A continuous output current for high power LED application, and utilizes PWM control scheme that switches with 300KHz fixed frequency.

The input voltage range of AF1505 is from 4.2V to 40V. It is suitable for series-parallel 1W, 3W, or 5W high power LED application due to the high operation voltage and output capability. At 24V input voltage, this device can drive up to 30pcs 1W LED (6S-5P) with constant 350mA LED current.

The PWM control circuit is able to vary the duty ratio linearly from 0 up to 100%. This device also contains an error amplifier circuit as well as a soft-start circuit that prevents overshoot at startup. An enable function, an over current protect function and a short circuit protect function are built inside, and when OCP or SCP happens, the operation frequency will be reduced from 300KHz to 60KHz. Also, an internal compensation block is built in to minimum external component count. The package is available in a standard SOP-8P.

Features

- Input voltage: 4.2V to 40V.
- Low Feedback Voltage 0.21V.
- Driving up to 30 LEDs (1W 6S-5P) at 24V_{IN}
- Oscillation frequency: 300KHz typ.
- Soft-start, Current limit, Enable function
- Great Output Capability
- PWM or Analog Dimming Control
- Thermal Shutdown function
- Built-in internal P-channel MOS
- SOP-8P Package.

Application

- High Power LED Driver
- Backlight Application
- General Lighting Solution
- Constant Current Source

Pin Define (SOP-8P)

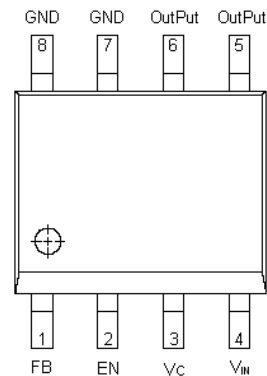

Marking Information

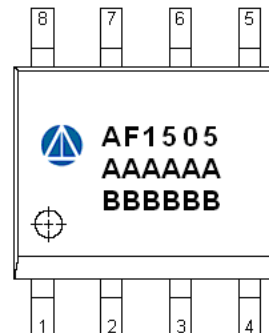



Typical Application Circuit

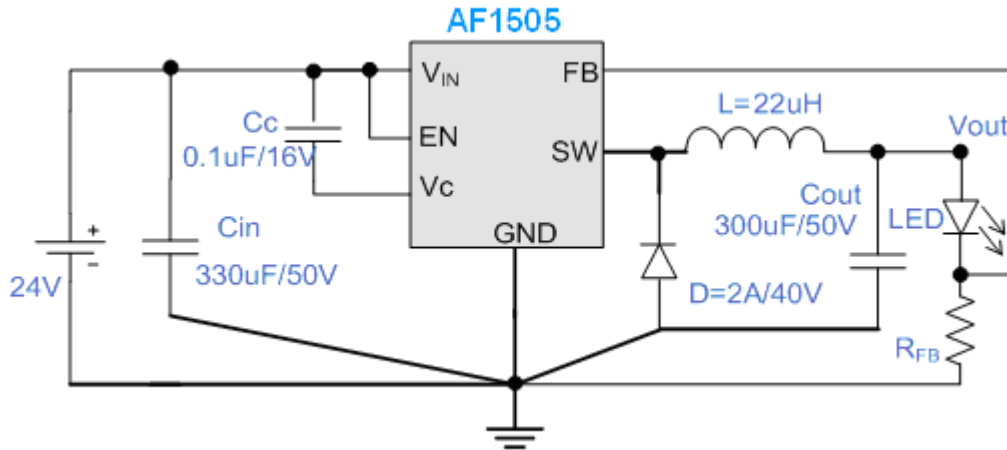

Pin Description

Pin	Symbol	Description
FB	1	Feedback pin Connect to a resistor to set LED current by following formula : $I_{LED} = 0.23V/R_{FB}$
EN	2	Enable / Disable pin H: Normal operation mode. (Step-down operation) L: Shutdown mode. (All circuits deactivated)
V _C	3	Add an external capacitor to V _{IN} . It's voltage is set to V _{IN} -7V
V _{IN}	4	IC power supply pin
Output	5 · 6	Switch Pin. Connect external inductor/diode here. Minimize trace area at this pin to reduce EMI.
GND	7 · 8	GND Pin

Ordering Information

Part Ordering No.	Part Marking	Package	Unit	Quantity
AF1505S8RG	AF1505	SOP-8P	Tape & Reel	2500 EA

- ※ A Lot code
- ※ B Date code
- ※ AF1505S8RG : 13" Tape & Reel ; Pb- Free ; Halogen- Free



Block Diagram

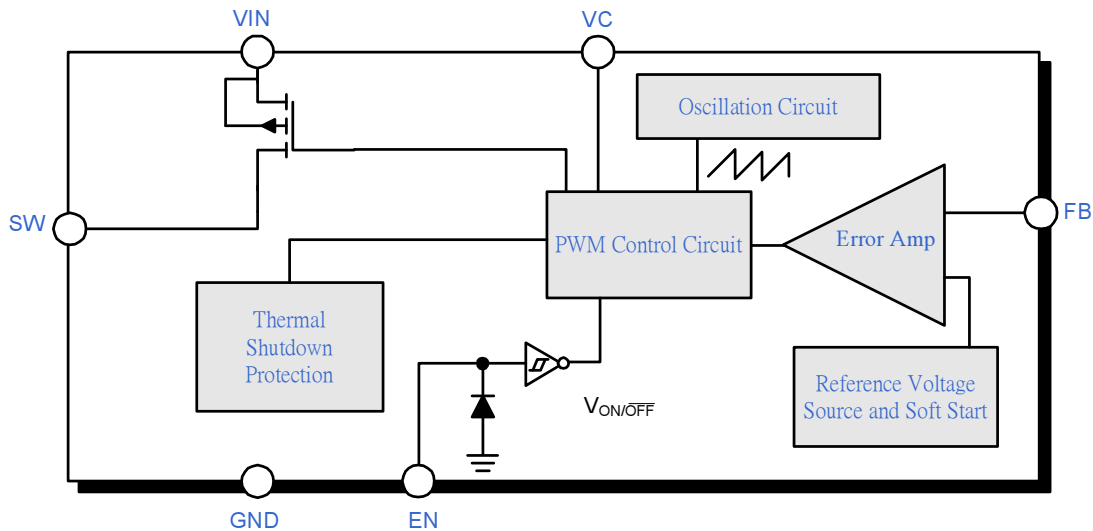

Absolute Maximum Ratings ($T_A=25^{\circ}\text{C}$ Unless otherwise noted)

The following ratings designate persistent limits beyond which damage to the device may occur.

Symbol	Parameter	Value	Unit
$V_{IN}^{(1)}$	V_{IN} Pin Voltage	GND - 0.3 to GND + 42	V
V_{FB}	Feedback Pin Voltage	GND - 0.3 to V_{IN}	V
$V_{ON/OFF}^{(1)}$	ON/OFF Pin Voltage	GND - 0.3 to $V_{IN} + 0.3$	V
V_{OUTPUT}	Switch Pin Voltage	GND - 0.3 to $V_{IN} + 0.3$	V
P_D	Power Dissipation	Internally limited	mW
T_{OPR}	Operating Temperature Range	-20 to +125	$^{\circ}\text{C}$
T_{STG}	Storage Temperature Range	-40 to +150	$^{\circ}\text{C}$

Caution:

1. The absolute maximum ratings are rated values exceeding which the product could suffer physical damage. These values must therefore not be exceeded under any conditions.



Electrical Characteristics

($T_A=25^{\circ}\text{C}$, $V_{CC}=24\text{V}$, unless otherwise specified.)

Symbol	Parameter	Conditions	Min.	Typ.	Max.	Unit
V_{IN}	Input Voltage		4.2		40	V
V_{ENH}	EN Pin Input Voltage	Evaluate oscillation at SW pin	2.0			V
V_{ENL}		Evaluate oscillation stop at SW pin			0.8	
V_{FB}	Feedback Voltage	$I_{OUT}=0.1\text{A}$	0.1995	0.21	0.2205	V
I_{FB}	Feedback Bias Current	$I_{OUT}=0.1\text{A}$	-	0.1	0.5	μA
I_{CL}	Current Limit		2.5			A
I_{GND}	Quiescent Current (switch off)	$EN \geq V_{EN_H}$, $V_{FB} = 1\text{V}$		1	2	mA
I_{GND_OFF}	Current Consumption During Power Off	$EN \leq V_{EN_L}$		1	10	μA
V_C	Voltage Clamp	No load	$V_{IN}-6$	$V_{IN}-7$	$V_{IN}-8$	V
F_{OSC}	Oscillation Frequency	Measure waveform at SW pin	240	300	360	KHz
F_{OSC1}	Frequency of Current Limit or Short Circuit Protect	Measure waveform at SW pin	30	60	90	KHz
$\frac{\Delta V_{OUT}}{V_{OUT}}$	Line Regulation	$V_{IN}=12\text{V}\sim 40\text{V}$, $I_{OUT}=0.2\text{A}$		1	2	%
$\frac{\Delta V_{OUT}}{V_{OUT}}$	Load Regulation	$I_{OUT}=0.1$ to 2A		0.2	0.5	%
$R_{DS(ON)}$	Internal MOSFET Rdson	$V_{FB}=0\text{V}$, $I_{OUT}=1\text{A}$		80	100	m Ω
η	Efficiency	$V_{IN}=24\text{V}$, 6pcs LED, $I_{OUT}=2\text{A}$	95			%

Function Description



PWM Control

The AF1505 consists of DC/DC converters that employ a pulse-width modulation (PWM) system.

In converters of the AF1505 the pulse width varies in a range from 0 to 100%, according to the load current. The ripple voltage produced by the switching can easily be removed through a filter because the switching frequency remains constant. Therefore, these converters provide a low-ripple power over broad ranges of input voltage and load current.

Current Limit and short circuit protection

The device includes current limit and short protection. When inductor current large than current limit threshold or the V_o is shorted to GND, then the protection circuit will be triggered and force the oscillation frequency down to approximately 60Khz. The oscillation frequency will return to the normal value once the feedback voltage rises above 0.23V.

Delay Start-up

The following circuit uses the EN pin to provide a time delay between the input voltages is applied and the output voltage comes up. As the instant of the input voltage rises, the charging of the capacitor C_{DELAY} pulls the EN pin low, keeping the device of. Once the capacitor voltage rises above the EN pin threshold voltage, the device will start to operate.

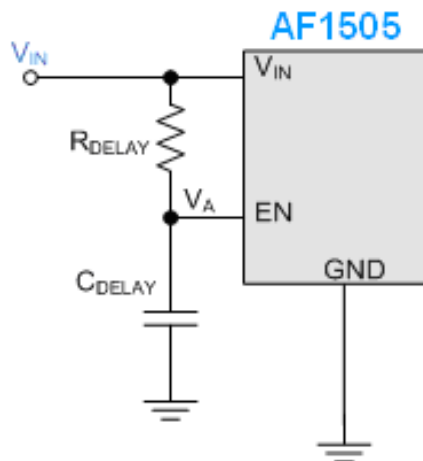

For example, setting $V_{IN}=24V$, $R_{DELAY}=100K\Omega$, $C_{DELAY}=0.1\mu F$. The start-up delay time can be calculated as below:

$$V_A = V_{IN} * (1 - e^{-\tau/t}) \geq V_{EN};$$
$$t = R_{DELAY} * C_{DELAY}$$
$$T \geq 1.147ms$$



Where V_A is the capacitor voltage, V_{EN} is the EN threshold voltage ($1.3V_{TYP}$), T is the delay time, and τ is the RC time constant.

This feature is useful in the situations where the input power source is limited in the amount of current it can deliver. It allows the input voltage to rise to higher voltage before the device starts operating.



Application Information

LED Current Sensing

This device is a constant current buck regulator that develops 0.23V reference voltage between the feedback pin and GND pin. Therefore, the use 1% chip resistors to attain the better current accuracy.

The LED current is given by the following equation:

$$I_{LED} = \frac{V_{FB}}{R_{FB}} ; V_{FB}=0.23V$$

The resistor's power dissipation can be calculation by the following equation:

$$P_{RFB} = I_{LED} \times V_{FB}$$

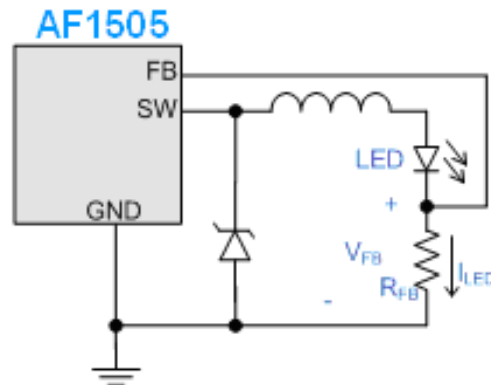

Dimming Control

Analog Dimming control

The analog dimming control using a DC voltage (V_{DIM}) is shown in the following circuit. As the V_{DIM} increases, the voltage drop on R2 increases. Thus the LED current decreases. The R1 and R2 must take the DC source current much larger than FB bias current and much smaller than the LED current.

The LED current can be calculated by the following equation:

$$I_{LED} = \frac{V_{FB} \times (R1 + R2) - V_{DIM} \times R2}{R1 \times R_{FB}}$$

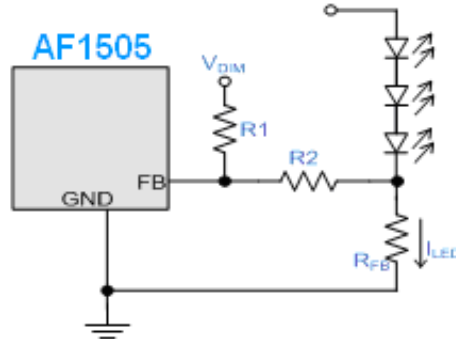

If the V_{DIM} is taken below the V_{FB} , the inverse will happen and brightness will increase.

The analog dimming circuit can be tailored for different resistor value using the following equation:

$$R1 = \frac{(V_{DIM_MAX} - V_{FB}) \times R2}{V_{FB} \times \left(1 - \frac{I_{LED_DIMMED_MIN}}{I_{LED_UNDIMMED}}\right)}$$

Example:

$$V_{DIM_MAX} = 5V$$

$$I_{LED_DIMMED_MIN} = 17.5mA ; V_{DIM} = 5V$$

$$I_{LED_UNDIMMED_MIN} = 350mA ; V_{DIM} = V_{FB} = 0.23V$$

$$R2 = 5K\Omega \rightarrow R1 = 120k\Omega$$

The analog dimming circuit can be tailored for different dimming voltage range using the following equation:

$$V_{DIM} = V_{FB} \times \frac{R1}{R2} \times \left(1 + \frac{R1}{R2} - \frac{I_{LED_DIMMED_MIN}}{I_{LED_UNDIMMED}}\right)$$

Filtered PWM Dimming from FB

Filtered PWM circuit can be used to place the DC voltage in the dimming control. The circuit is shown in the following figure that is suitable for the high frequency PWM control signal.

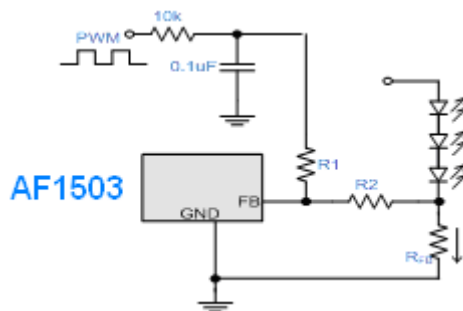



Snubber Circuit

The simple RC snubber is used for the voltage transient and ringing suppression. The high frequency ringing and voltage overshooting at the SW pin is caused by the fast switching transition and resonating circuit parasitical elements in the power circuit. It maybe generates EMI and interferes with circuit performance.

Reserve a snubber circuit in the PC board is preferred to damp the ringing due to the parasitical capacitor and inductor of layout. The following circuit is a simple RC snubber.

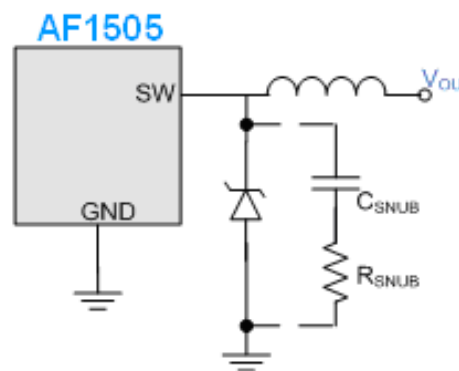

Choose the value of RC network by the following procedure:

1. Measure the voltage ringing by the frequency (f_R) of the SW pin.
2. Find a small capacitor and place it across the SW pin and the GND pin to damp the ringing frequency by half.
3. The parasitical capacitor (C_{PAR}) at the SW pin is 1/3 the value of the added capacitor above. The parasitical inductance (L_{PAR}) at the SW pin is:

$$L_{PAR} = \frac{1}{(2\pi f_R)^2 \times C_{PAR}}$$

4. Select the value of C_{SNUB} that should be more than 2~4 times the value of C_{PAR} but must be small enough so that the power dissipation of R_{SNUB} is kept to a minimum. The power rating of R_{SNUB} can be calculated by follow equation:

$$P_{SNUB} = C_{SNUB} \times V_{IN}^2 \times f_S$$

5. Calculate the value of R_{SNUB} by the following equation and adjust the value to meet the expectative peak voltage.

$$R_{SNUB} = 2\pi \times f_R \times L_{PAR}$$



Thermal Considerations

Thermal protection limits total power dissipation in the device. When the junction temperature reaches approximately 150°C the thermal sensor signals the shutdown logic turning off this device. The thermal sensor will turn this device on again after the IC's junction temperature cools by 55°C. For continuous operation, do not exceed the maximum operation junction temperature 125°C.

The power dissipation across this device can be calculated by following equation:

$$P_D = I_{LED}^2 \times R_{DS(ON)} \times D + \frac{1}{2} \times V_{IN} \times I_{LED} \times (tr + tf) \times f_s + Q_{GATE} \times V_{GS} \times f_s + I_Q \times V_{IN}$$

Where:

D : Duty Cycle

f_s : Switching Frequency

V_{GS} : Power MOSFET Gate Voltage

I_Q : Quiescent Current

The tr, tf and Q_{GATE} are the rising, falling time, and gate charge of the power MOSFET. The typical value of (tr+tf) is approximately 30ns, and the Q_{GATE} is approximately 10nC. The V_{GS} is approximately equal V_{IN}.

The Maximum power dissipation of this device depends on the thermal resistance of the IC package and PCB layout, the temperature difference between the junction and ambient air, and the rate of airflow. The maximum power dissipation can be calculated by the following equation:

$$P_{D(MAX)} = \frac{T_J - T_A}{\theta_{JA}}$$

Where T_J-T_A is the temperature difference between the junction and surrounding environment. The value of junction to case thermal resistance θ_{Jc} is also popular to users. This thermal parameter is convenient for users to estimate the internal junction operated temperature of packages while IC operating. The operated junction temperature can be calculated by the following equation :

$$T_J = T_C + P_D \times \theta_{Jc}$$



T_C is the package case temperature measured by thermal sensor. Therefore it's easy to estimate the junction temperature by any condition.

There are many factors affect the thermal resistance. Some of the factors include trace width, copper thickness, total PCB copper area, and etc.

For the best thermal performance, wide copper tracks and generous amounts of PCB copper should be used in board layout. If further improve thermal characteristics are needed, double sided and multi-layer PCB with large copper areas and airflow will be recommended.

Layout consideration

PC board layout is very important, especially for switching regulators of high frequencies and large peak currents. A good layout minimizes EMI on the feedback path and provides best efficiency. The following layout guides should be used to ensure proper operation of this device.

1. The power charge path that consists of the V_{IN} trace, SW trace, external inductor, and the GND trace should be kept wide and as short as possible.
2. The power discharge path that consists of SW trace, external inductor, external diode and the GND trace should kept wide and as short as possible.
3. The feedback path of the voltage divider should be close to FB pin and keep noisy traces away; also keep them separate using grounded copper.
4. The input capacitors should be close to the regulator and rectifier diode. The output capacitors should be close to the load.
5. Keep the (-) plates of input and output capacitor as close as possible.

Inductor Selection

The conduction mode of power stage depends on input voltage, output voltage, LED current, and the value of the inductor. Select an inductor to maintain this device operating in continuous conduction mode (CCM). The minimum value of inductor can be determined by the following procedure.

1. Calculate the minimum duty ratio

$$D_{(MIN)} = \frac{V_{OUT} + I_{LED} \times R_L + V_F}{V_{IN(MAX)} - I_{LED} \times R_{DS(ON)} + V_F} = \frac{T_{ON}}{T_S}$$

Where R_L is the DC resistance of the external inductor, V_F is the forward voltage of external diode, and T_S is the switching period.

This equation can be simplified to

$$D_{(MIN)} = \frac{V_{OUT}}{V_{IN(MAX)}} = \frac{T_{ON}}{T_S} ; 0 \leq D \leq 1$$



2. Defined a value of minimum LED current that is approximately 10%~30% of full LED current to maintain continuous conduction mode, usually referred to as the critical current (I_{CRIT}).

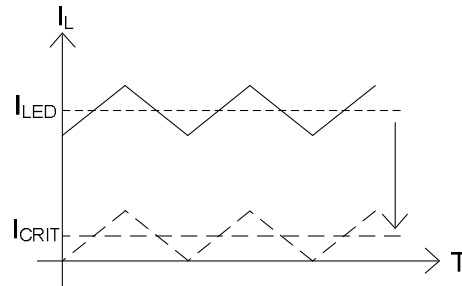

$$I_{CRIT} = \delta \times I_{LED} ; \delta = 0.1 \sim 0.3$$

3. Calculate the inductor ripple current (ΔI_L). In steady state conditions, the inductor ripple current increase, (ΔI_{L+}), during the ON time and the current decrease, (ΔI_{L-}), during the OFF time must be equal.

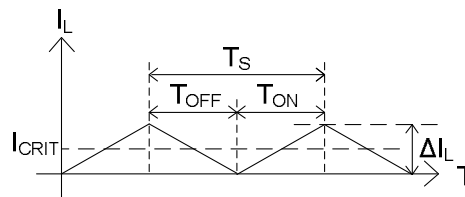

4. Calculate the minimum value of the inductor use maximum input voltage. That is the worst case condition because it gives the maximum ΔI_L .

$$L \geq \frac{[V_{IN(MAX)} - I_{LED} \times (R_{DS(ON)} + R_L) - V_{OUT}] \times D_{(MIN)}}{\Delta I_L \times f_S}$$

This equation can be simplified to

$$\geq \frac{(V_{IN(MAX)} - V_{OUT}) \times D_{(MIN)}}{\Delta I_L \times f_S}$$

The higher value inductor results in lower output ripple current and ripple voltage. It also reduces the conduction loss. But higher value inductor requires larger physical size and price.

5. Calculate the inductor peak current and choose a suitable inductor to prevent saturation.

$$I_{L(PEAK)} = I_{LED} + \frac{\Delta I_L}{2}$$

Coil inductor and surface mount inductors are all available. The surface mount inductors can reduce the board size but they are more expensive and its larger DC resistance results in more conduction loss. The power dissipation is due to the DC resistance can be calculated as below :

$$P_{D_INDUCTOR} = I_{LED}^2 \times R_L$$



Output Capacitor Selection

The functions of the output capacitor are to store energy and maintain the output voltage. The low ESR (Equivalent Series resistance) capacitors are preferred to reduce the output ripple voltage (ΔV_{OUT}) and conduction loss. The output ripple voltage can be calculated as below:

$$\Delta V_{OUT} = \Delta I_L \times (ESR_{COUT} + \frac{1}{8 \times f_S \times C_{OUT}})$$

The ESR of the aluminum electrolytic or tantalum output capacitor is an important parameter to determine the output ripple voltage. But the manufactures usually do not specify ESR in the specifications, Assuming the capacitor is enough results in the output ripple voltage is due to the capacitor can be ignored, the ESR can be calculated as below :

$$ESR_{COUT} \leq \frac{\Delta V_{OUT}}{\Delta I_L}$$

Choose the output capacitor by the average value of the RC product as below :

$$C_{OUT} \approx \frac{50 \sim 80 \times 10^{-6}}{ESR_{COUT}}$$

The ESR and ripple current results power dissipation in the capacitor. It will increase the internal temperature. Usually, the capacitors manufactures specify ripple current ratings and should not exceeds to prevent excessive temperature shorten the lift time. Choose a smaller inductor causes higher ripple current which maybe result in the capacitor overstress. The RMS ripple current flowing through the output capacitor and power dissipation can be calculated as below :

$$I_{RMS_COUT} = \frac{\Delta I_L}{\sqrt{12}} = \Delta I_L \times 0.289$$

$$P_{D_COUT} = (I_{RMS_COUT})^2 \times ESR_{COUT}$$

Besides, the capacitor's ESL (Equivalent Series inductance) maybe causes ringing in the low Mhz region. Choose low ESL capacitors, and parallel connecting several smaller capacitors to replace with a larger one will reduce the ringing phenomenon.



Input Capacitor Selection

The input capacitor is required to supply current to the regulator and maintain the DC input voltage. Low ESR capacitors are preferred as they provide better performance and less ripple voltage.

1. The input capacitors need an adequate RMS current rating. It can be calculated by the following equation and should not be exceeded.

$$I_{RMS_CIN} = I_{LED(MAX)} \times \sqrt{D \times (1-D)}$$

This equation has a maximum at $V_{IN}=2V_{OUT}$. That is the worst case and the above equation can be simplified to :

$$I_{RMS_CIN} = \frac{I_{LED(MAX)}}{2}$$

Therefore, choose a suitable capacitor at the input whose ripple current rating must be greater than half of the maximum LED current.

2. The input ripple voltage (ΔV_{IN}) mainly depends on the input capacitor's ESR and its capacitance. Assuming the input current of the regulator is constant, the required input capacitance for a given input ripple voltage can be calculated as below :

$$C_{IN} = \frac{I_{LED(MAX)} \times D \times (1-D)}{f_S \times (V_{IN} - I_{LED(MAX)} \times ESR_{CIN})}$$

If using aluminum electrolytic or tantalum input capacitors, parallel connecting a 0.1uF ceramic capacitor as close to the V_{IN} pin of the regulator as possible. If using a ceramic capacitor, make sure the capacitance is enough to prevent the excessive input ripple current.

3. The power dissipation of the input capacitor causes a small conduction loss, which can be calculated as below :

$$P_{D_CIN} = (I_{RMS_CIN})^2 \times ESR_{CIN}$$



Package Information (SOP-8P)

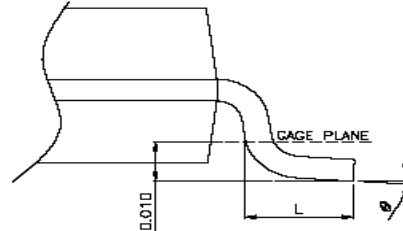
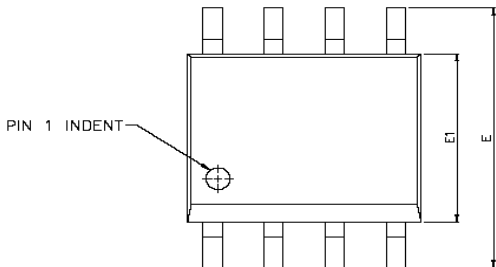

DETAIL A

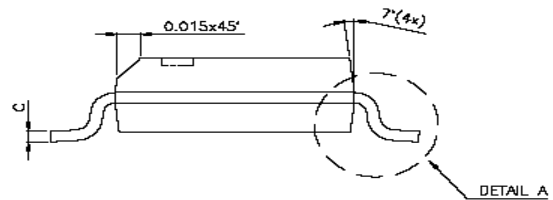
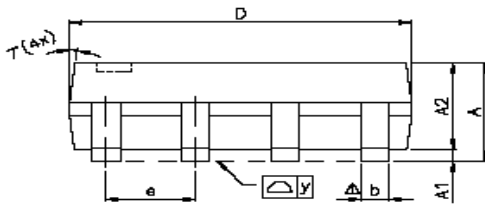

DETAIL A

SYMBOLS	DIMENSIONS IN MILLIMETERS			DIMENSIONS IN INCHES		
	MIN	NOM	MAX	MIN	NOM	MAX
A	1.47	1.60	1.73	0.058	0.063	0.068
A1	0.10	—	0.25	0.004	—	0.010
A2	—	1.45	—	—	0.057	—
b	0.33	0.41	0.51	0.013	0.016	0.020
C	0.19	0.20	0.25	0.0075	0.008	0.0098
D	4.80	4.85	4.95	0.189	0.191	0.195
E	5.80	6.00	6.20	0.228	0.236	0.244
E1	3.80	3.90	4.00	0.150	0.154	0.157
e	—	1.27	—	—	0.050	—
L	0.38	0.71	1.27	0.015	0.028	0.050
Δ y	—	—	0.076	—	—	0.003
θ	0°	—	8°	0°	—	8°

©2010 Alfa-MOS Technology Corp.
 2F, No.80, Sec.1, Cheng Kung Rd., Nan Kang Dist., Taipei City 115, Taiwan (R.O.C.)
 Tel : 886 2) 2651 3928
 Fax : 886 2) 2786 8483
 ©http://www.alfa-mos.com