



## General Description

AFC5604, N & P Pair enhancement mode MOSFET, uses Advanced Trench Technology to provide excellent RDS(ON), low gate charge. These devices are particularly suited for low voltage power management, and low in-line power loss are needed in commercial industrial surface mount applications.

## Features

N-Channel

- 40V/15A,  $R_{DS(ON)} = 20m\Omega @ V_{GS} = 10V$
- 40V/12A,  $R_{DS(ON)} = 30m\Omega @ V_{GS} = 4.5V$

P-Channel

- -40V/-15A,  $R_{DS(ON)} = 38m\Omega @ V_{GS} = -10V$
- -40V/-12A,  $R_{DS(ON)} = 54m\Omega @ V_{GS} = -4.5V$

## Pin Description ( TO-252-4L )

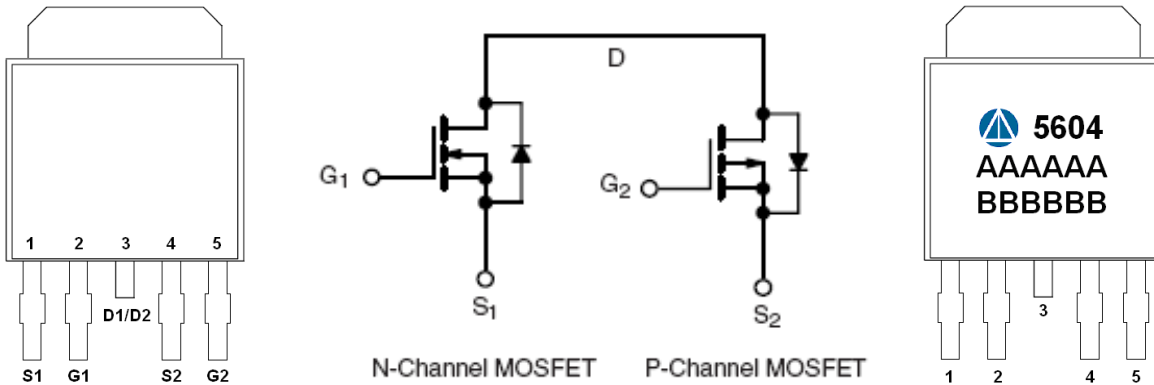

## Application

- DC/DC Conversion
- Load Switch
- DC FAN

## Pin Define

Pin	Symbol	Description
1	S1	Source 1
2	G1	Gate 1
3	D1 / D2	Drain 1 / Drain 2
4	S2	Source 2
5	G2	Gate 2

## Ordering Information

Part Ordering No.	Part Marking	Package	Unit	Quantity
AFC5604T254RG	5604	TO-252-4L	Tape & Reel	2500 EA

※ A Lot code

※ B Date code

※ AFC5604T254RG : 13" Tape & Reel ; Pb- Free ; Halogen -Free



**Absolute Maximum Ratings ( N-Channel )**

(T<sub>A</sub>=25°C Unless otherwise noted)

Parameter	Symbol	Value	Unit
Drain-Source Voltage	V <sub>DSS</sub>	40	V
Gate –Source Voltage	V <sub>GSS</sub>	±20	V
Continuous Drain Current(T <sub>J</sub> =150°C)	I <sub>D</sub>	T <sub>A</sub> =25°C	8.0
		T <sub>A</sub> =70°C	6.0
Pulsed Drain Current	I <sub>DM</sub>	20	A
Continuous Source Current(Diode Conduction)	I <sub>S</sub>	1.5	A
Power Dissipation	P <sub>D</sub>	T <sub>A</sub> =25°C	2.8
		T <sub>A</sub> =70°C	1.8
Operating Junction Temperature	T <sub>J</sub>	150	°C
Storage Temperature Range	T <sub>STG</sub>	-55/150	°C
Thermal Resistance-Junction to Ambient	R <sub>θJA</sub>	62.5	°C/W

**Electrical Characteristics ( N-Channel )**

(T<sub>A</sub>=25°C Unless otherwise noted)

Parameter	Symbol	Conditions	Min.	Typ	Max.	Unit
<b>Static</b>						
Drain-Source Breakdown Voltage	V <sub>(BR)DSS</sub>	V <sub>GS</sub> =0V, I <sub>D</sub> =250uA	40			V
Gate Threshold Voltage	V <sub>GS(th)</sub>	V <sub>DS</sub> =V <sub>GS</sub> , I <sub>D</sub> =250uA	1.0		3.0	
Gate Leakage Current	I <sub>GSS</sub>	V <sub>DS</sub> =0V, V <sub>GS</sub> =±20V			±100	nA
Zero Gate Voltage Drain Current	I <sub>DSS</sub>	V <sub>DS</sub> =32V, V <sub>GS</sub> =0V			1	uA
		V <sub>DS</sub> =32V, V <sub>GS</sub> =0V T <sub>J</sub> =85°C			10	
On-State Drain Current	I <sub>D(on)</sub>	V <sub>DS</sub> ≥ 5V, V <sub>GS</sub> =10V	20			A
Drain-Source On-Resistance	R <sub>DS(on)</sub>	V <sub>GS</sub> =10V, I <sub>D</sub> =15A		13	20	mΩ
		V <sub>GS</sub> =4.5V, I <sub>D</sub> =12A		18	30	
Forward Transconductance	g <sub>FS</sub>	V <sub>DS</sub> =15V, I <sub>D</sub> =5.0A		25		S
Diode Forward Voltage	V <sub>SD</sub>	I <sub>S</sub> =2A, V <sub>GS</sub> =0V		0.85	1.2	V
<b>Dynamic</b>						
Total Gate Charge	Q <sub>g</sub>	V <sub>DS</sub> =20V, V <sub>GS</sub> =4.5V I <sub>D</sub> = 5A		10	14	nC
Gate-Source Charge	Q <sub>gs</sub>			2.8		
Gate-Drain Charge	Q <sub>gd</sub>			3.2		
Input Capacitance	C <sub>iss</sub>	V <sub>DS</sub> =20V, V <sub>GS</sub> =0V f=1MHz		850		pF
Output Capacitance	C <sub>oss</sub>			110		
Reverse Transfer Capacitance	C <sub>rss</sub>			75		
Turn-On Time	t <sub>d(on)</sub>	V <sub>DD</sub> =20V, R <sub>L</sub> =4Ω I <sub>D</sub> ≅5.0A, V <sub>GEN</sub> =10V		6	12	ns
	t <sub>r</sub>			10	20	
Turn-Off Time	t <sub>d(off)</sub>		R <sub>G</sub> =1Ω		20	
	t <sub>f</sub>			6	12	



### Absolute Maximum Ratings ( P-Channel )

( $T_A=25^\circ\text{C}$  Unless otherwise noted)

Parameter	Symbol	Value	Unit
Drain-Source Voltage	$V_{DSS}$	-40	V
Gate –Source Voltage	$V_{GSS}$	$\pm 20$	V
Continuous Drain Current( $T_J=150^\circ\text{C}$ )	$I_D$	$T_A=25^\circ\text{C}$	-7.0
		$T_A=70^\circ\text{C}$	-6.0
Pulsed Drain Current	$I_{DM}$	-30	A
Continuous Source Current(Diode Conduction)	$I_S$	-1.7	A
Power Dissipation	$P_D$	$T_A=25^\circ\text{C}$	2.8
		$T_A=70^\circ\text{C}$	1.8
Operating Junction Temperature	$T_J$	150	$^\circ\text{C}$
Storage Temperature Range	$T_{STG}$	-55/150	$^\circ\text{C}$
Thermal Resistance-Junction to Ambient	$R_{\theta JA}$	62.5	$^\circ\text{C/W}$

### Electrical Characteristics ( P-Channel )

( $T_A=25^\circ\text{C}$  Unless otherwise noted)

Parameter	Symbol	Conditions	Min.	Typ	Max.	Unit
<b>Static</b>						
Drain-Source Breakdown Voltage	$V_{(BR)DSS}$	$V_{GS}=0V, I_D = -250\mu\text{A}$	-40			V
Gate Threshold Voltage	$V_{GS(th)}$	$V_{DS}=V_{GS}, I_D = -250\mu\text{A}$	-1.0		-3.0	V
Gate Leakage Current	$I_{GSS}$	$V_{DS}=0V, V_{GS} = \pm 20V$			$\pm 100$	nA
Zero Gate Voltage Drain Current	$I_{DSS}$	$V_{DS} = -32V, V_{GS}=0V$			-1	uA
		$V_{DS} = -32V, V_{GS}=0V$ $T_J=85^\circ\text{C}$			-20	
On-State Drain Current	$I_{D(on)}$	$V_{DS} \geq -5V, V_{GS} = -10V$	-20			A
Drain-Source On-Resistance	$R_{DS(on)}$	$V_{GS} = -10V, I_D = -15A$		30	38	m $\Omega$
		$V_{GS} = -4.5V, I_D = -12A$		44	54	
Forward Transconductance	$g_{FS}$	$V_{DS} = -15V, I_D = -5A$		20		S
Diode Forward Voltage	$V_{SD}$	$I_S = -2A, V_{GS}=0V$		-0.8	-1.2	V
<b>Dynamic</b>						
Total Gate Charge	$Q_g$	$V_{DS}=-20V, V_{GS}=-4.5V$ $I_D = -5.0A$		13	20	nC
Gate-Source Charge	$Q_{gs}$		4.5			
Gate-Drain Charge	$Q_{gd}$		6.5			
Input Capacitance	$C_{iss}$	$V_{DS}=-20V, V_{GS}=0V$ $f=1\text{MHz}$		1100		pF
Output Capacitance	$C_{oss}$		145			
Reverse Transfer Capacitance	$C_{rss}$		115			
Turn-On Time	$t_{d(on)}$	$V_{DD}=-20V, R_L=4\Omega$ $I_D = -5.0A, V_{GEN}=-4.5V$ $R_G=1\Omega$		40	80	ns
	$t_r$			55	100	
Turn-Off Time	$t_{d(off)}$			30	60	
	$t_f$			12	20	



## Typical Characteristics ( N-Channel )

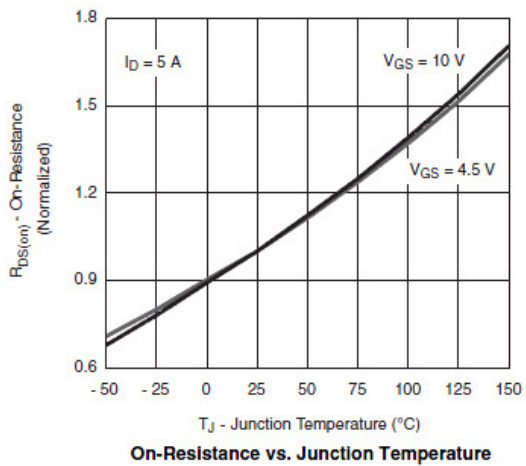
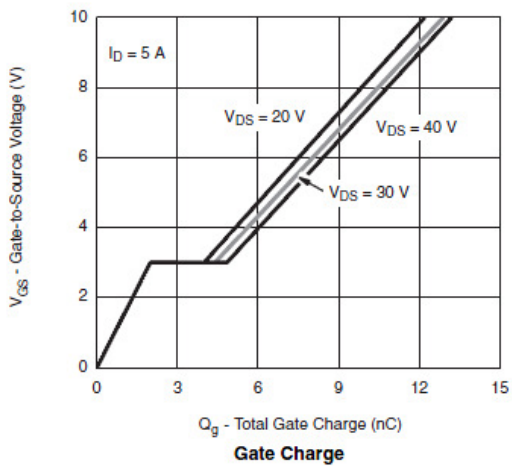
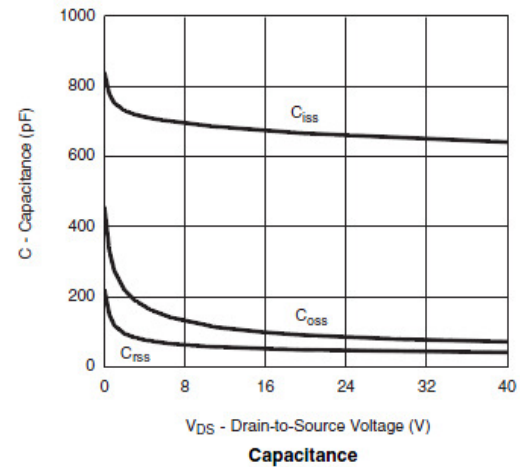
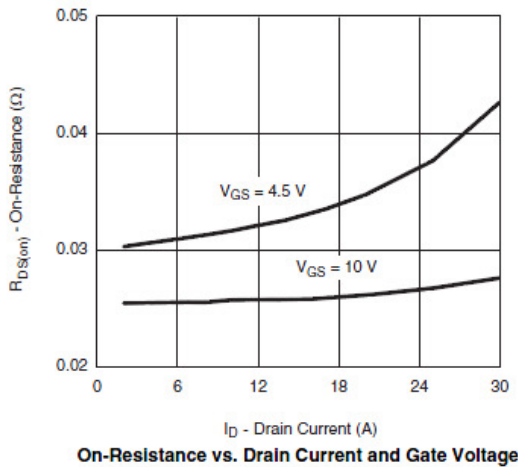
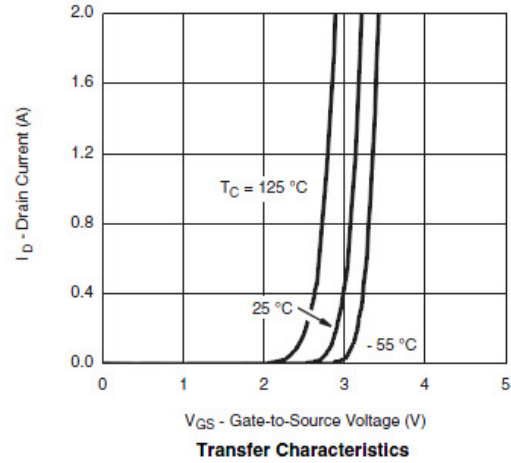
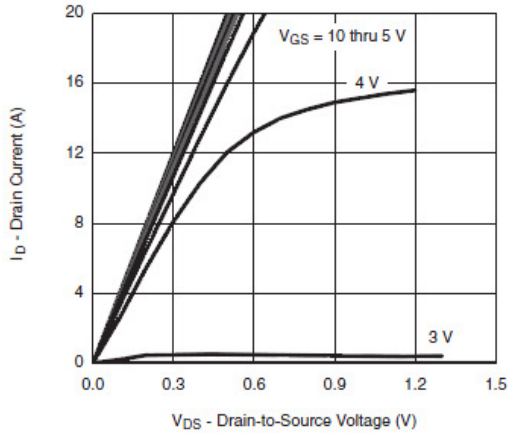



## Typical Characteristics ( N-Channel )

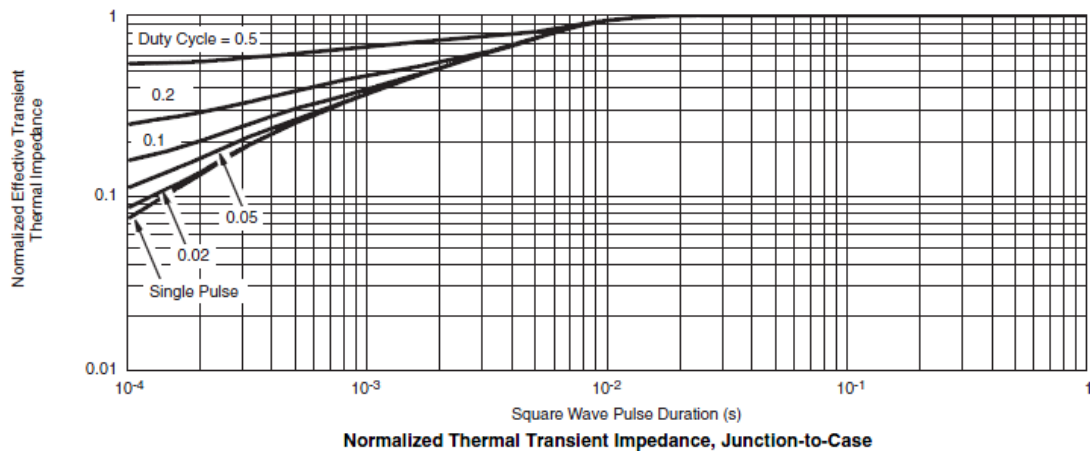
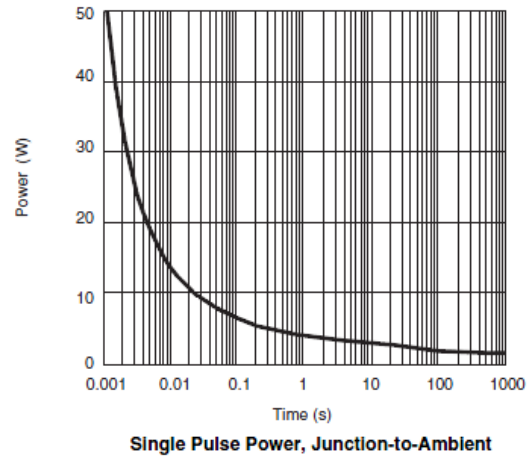
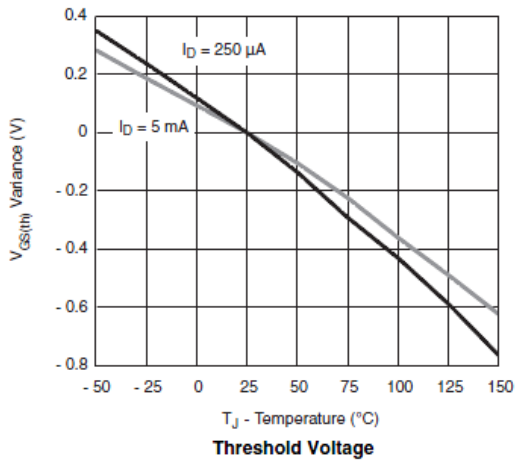
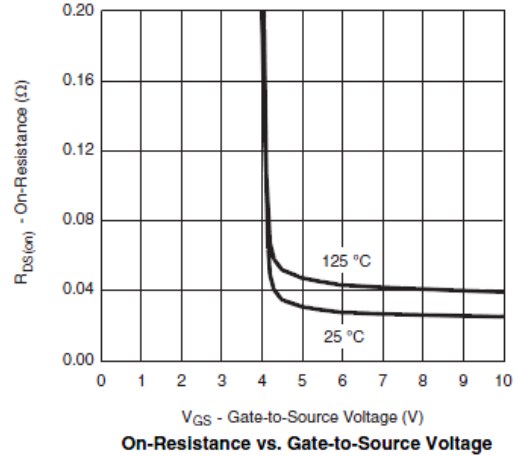
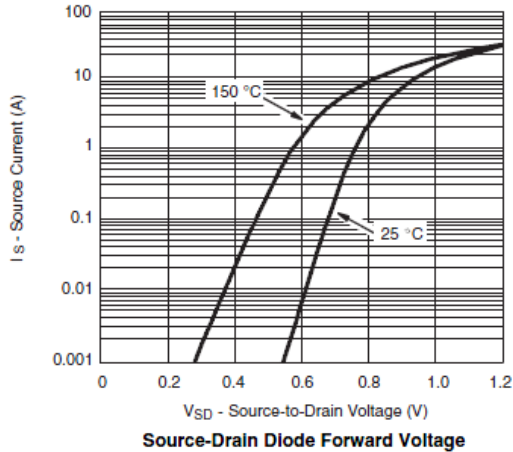



## Typical Characteristics ( P-Channel )

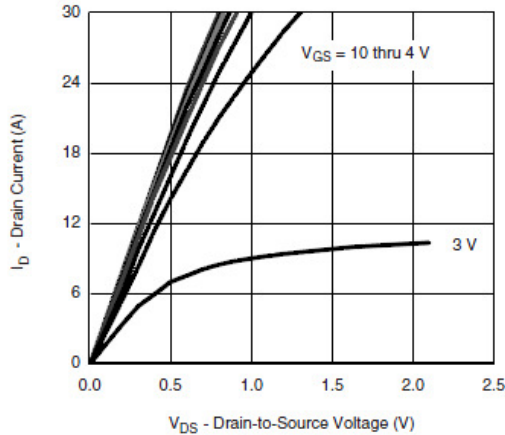

Output Characteristics

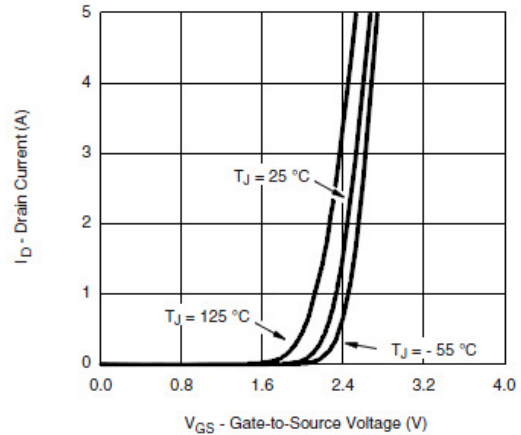

Transfer Characteristics

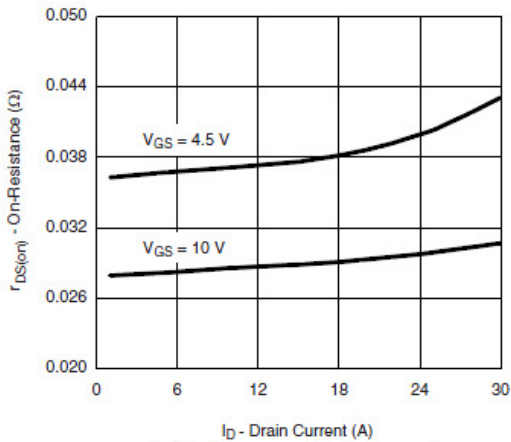

On-Resistance vs. Drain Current

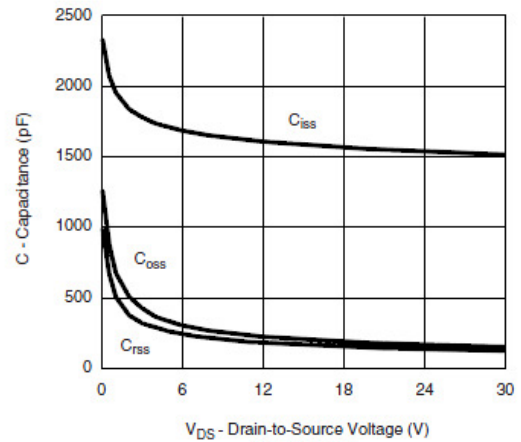

Capacitance

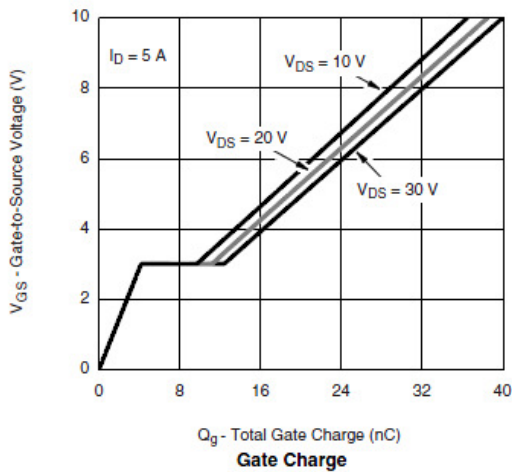

Gate Charge

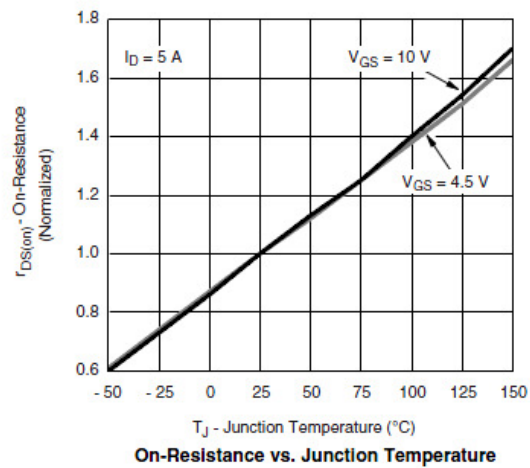

On-Resistance vs. Junction Temperature



**Typical Characteristics ( P-Channel )**

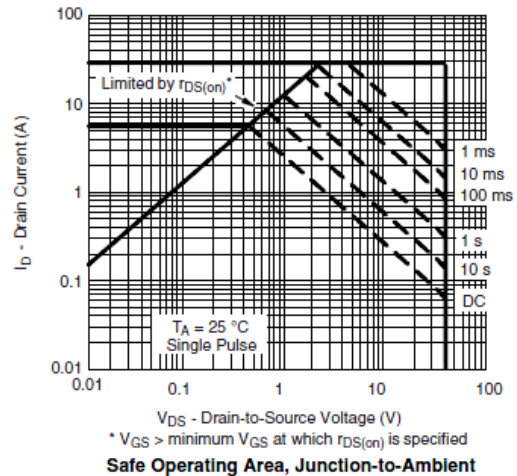
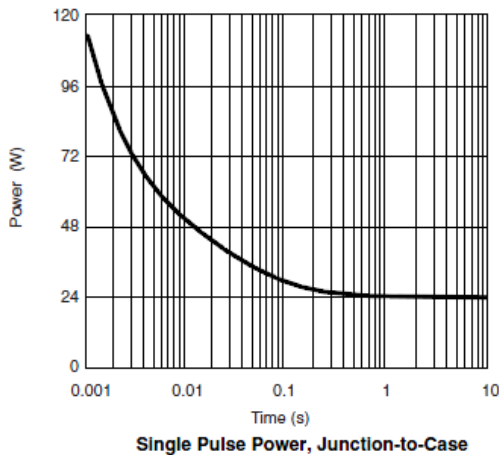
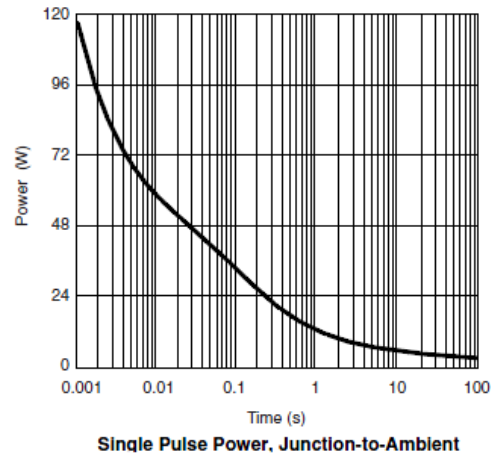
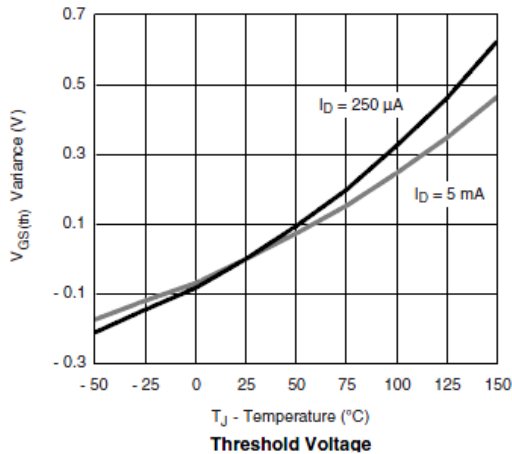
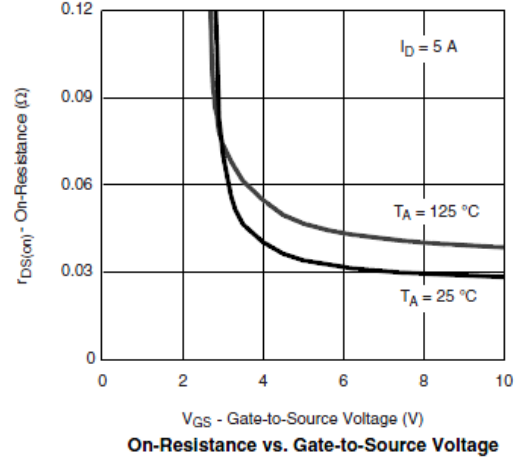
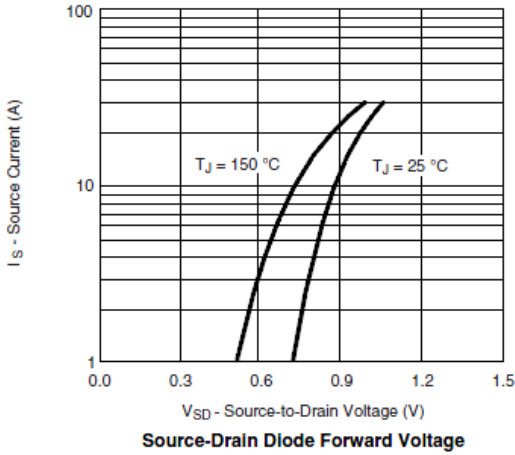



Typical Characteristics

Gate Charge Test Circuit & Waveform

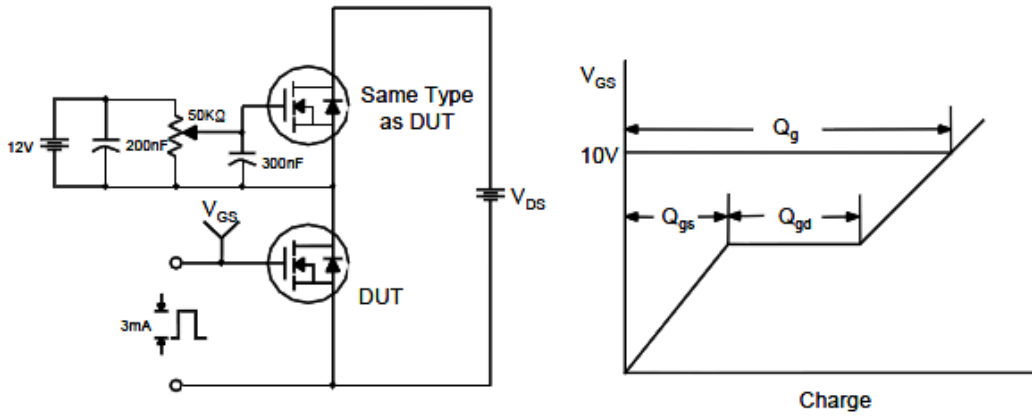

Resistive Switching Test Circuit & Waveforms

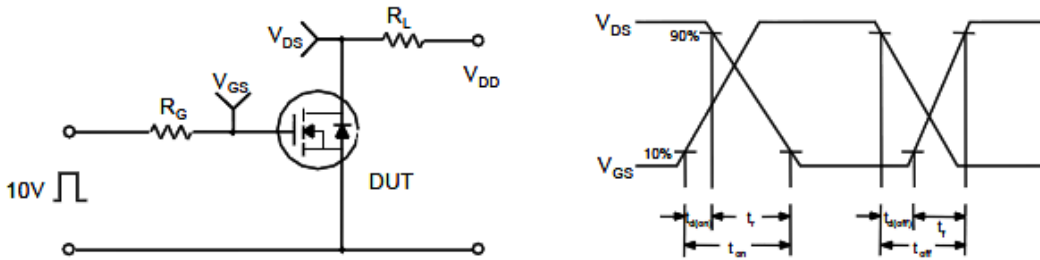

Unclamped Inductive Switching Test Circuit & Waveforms

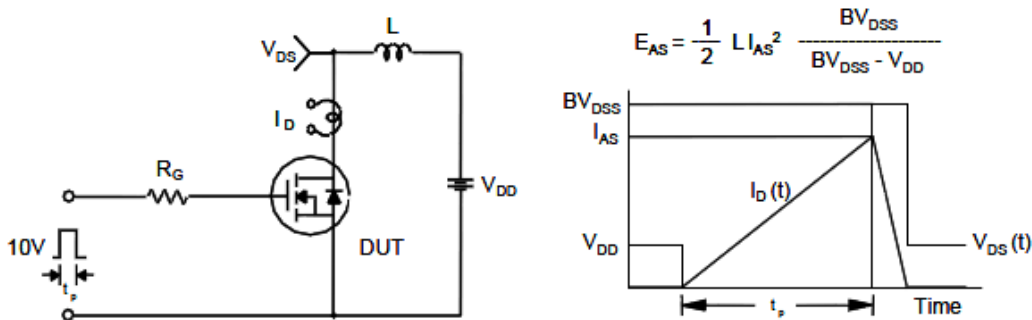





**Package Information ( TO-252-4L )**

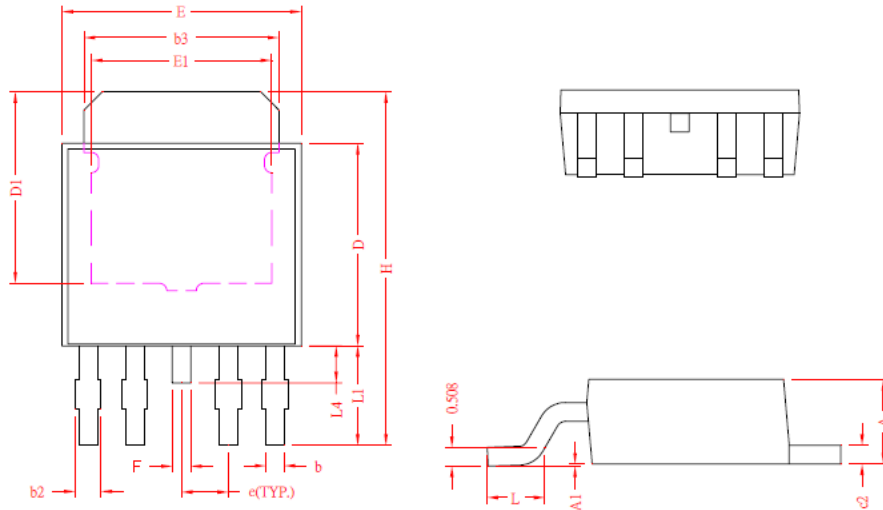

REF.	Millimeter		REF.	Millimeter	
	Min.	Max.		Min.	Max.
A	2.20	2.40	E	6.40	6.80
A1	0	0.15	E1	3.81	---
b	0.40	0.60	e	1.27 REF.	
b2	0.50	0.80	F	0.40	0.60
b3	5.20	5.50	H	9.40	10.20
c2	0.45	0.55	L	1.40	1.77
D	5.40	5.80	L1	2.40	3.00
D1	4.57	---	L4	0.80	1.20

©2010 Alfa-MOS Technology Corp.  
 2F, No.80, Sec.1, Cheng Kung Rd., Nan Kang Dist., Taipei City 115, Taiwan (R.O.C.)  
 Tel : 886 2) 2651 3928  
 Fax : 886 2) 2786 8483  
 ©http://www.alfa-mos.com