



General Description

AFN1330KS, N-Channel enhancement mode MOSFET, uses Advanced Trench Technology to provide excellent $R_{DS(ON)}$, low gate charge.

These devices are particularly suited for low voltage power management, such as smart phone and notebook computer and other battery powered circuits, and low in-line power loss are needed in commercial industrial surface mount applications.

Features

- 60V/0.5A , $R_{DS(ON)}=2400m\Omega@V_{GS}=10V$
- 60V/0.3A , $R_{DS(ON)}=3000m\Omega@V_{GS}=4.5V$
- Super high density cell design for extremely low $R_{DS(ON)}$
- Exceptional on-resistance and maximum DC current capability
- ESD Protection (2KV) Diode design-in
- SOT-323 package design

Pin Description (SOT-323)

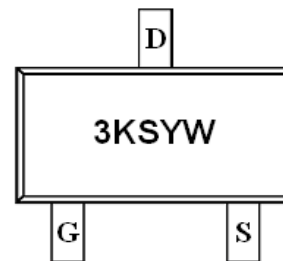
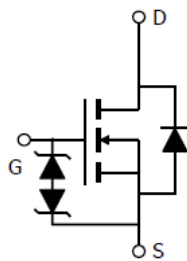
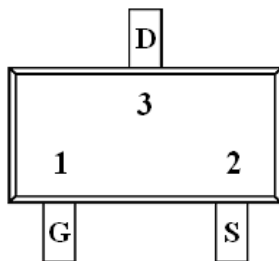

Application

- Drivers: Relays, Solenoids, Lamps, Hammers, Display, Memories, Transistors, etc.
- High saturation current capability. Direct Logic-Level Interface: TTL/CMOS
- Battery Operated Systems
- Solid-State Relays

Pin Define

Pin	Symbol	Description
1	G	Gate
2	S	Source
3	D	Drain

Ordering Information

Part Ordering No.	Part Marking	Package	Unit	Quantity
AFN1330KSS32RG	3KSYW	SOT-323	Tape & Reel	3000 EA

- ※ 3KS Parts code
- ※ Y Year code (0 ~ 9)
- ※ W Week code (A ~ Z = 1 ~ 26 / a ~ z = 27 ~ 52)
- ※ AFN1330KSS32RG : 7" Tape & Reel ; Pb- Free ; Halogen -Free



Absolute Maximum Ratings

(T_A=25°C Unless otherwise noted)

Parameter	Symbol	Value	Unit
Drain-Source Voltage	V _{DSS}	60	V
Gate –Source Voltage	V _{GSS}	±20	V
Continuous Drain Current(T _J =150°C)	I _D	T _A =25°C	0.5
		T _A =70°C	0.3
Pulsed Drain Current	I _{DM}	1.0	A
Continuous Source Current(Diode Conduction)	I _S	0.4	A
Power Dissipation	P _D	T _A =25°C	0.35
		T _A =70°C	0.22
Operating Junction Temperature	T _J	150	150
Storage Temperature Range	T _{STG}	-55/150	-55/150
Thermal Resistance-Junction to Ambient	R _{θJA}	120	120

Electrical Characteristics

(T_A=25°C Unless otherwise noted)

Parameter	Symbol	Conditions	Min.	Typ	Max.	Unit
Static						
Drain-Source Breakdown Voltage	V _{(BR)DSS}	V _{GS} =0V, I _D =250uA	60			V
Gate Threshold Voltage	V _{GS(th)}	V _{DS} =V _{GS} , I _D =250uA	1.0		2.0	
Gate Leakage Current	I _{GSS}	V _{DS} =0V, V _{GS} =±20V			3	uA
Zero Gate Voltage Drain Current	I _{DSS}	V _{DS} =60V, V _{GS} =0V			1	uA
		V _{DS} =60V, V _{GS} =0V T _J =85°C			10	
Drain-Source On-Resistance	R _{DS(on)}	V _{GS} =10V, I _D =0.5A		1200	2400	mΩ
		V _{GS} = 4.5V, I _D =0.3A		1600	3000	
Forward Transconductance	g _{FS}	V _{DS} =10V, I _D =0.2A		0.2		S
Diode Forward Voltage	V _{SD}	I _S =0.2A, V _{GS} =0V		0.75	1.4	V
Dynamic						
Total Gate Charge	Q _g	V _{DS} =10V, V _{GS} =4.5V I _D ≅0.25A		450		pC
Gate-Source Charge	Q _{gs}			110		
Gate-Drain Charge	Q _{gd}			150		
Input Capacitance	C _{iss}	V _{DS} =25V, V _{GS} =0V f=1MHz		30		pF
Output Capacitance	C _{oss}			8		
Reverse Transfer Capacitance	C _{rss}			5		
Turn-On Time	t _{d(on)}	V _{DD} =30V, R _L =150Ω I _D ≅0.2A, V _{GEN} =10V R _G =10Ω		4	10	ns
	t _r			5	15	
Turn-Off Time	t _{d(off)}			12	20	
	t _f			10	20	



Typical Characteristics

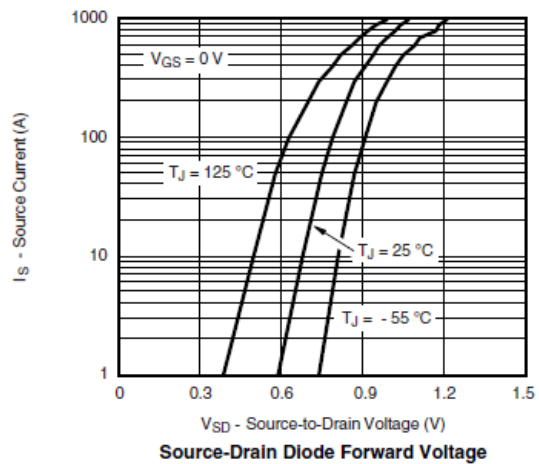
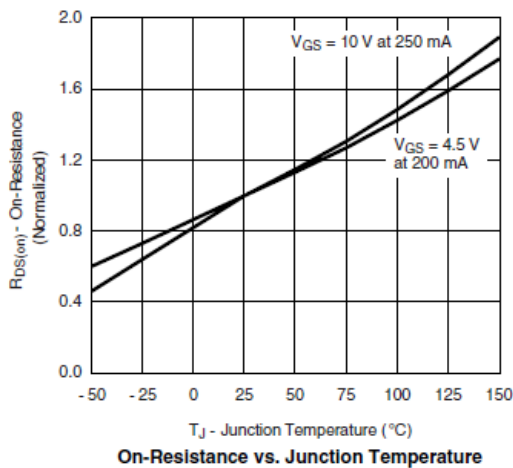
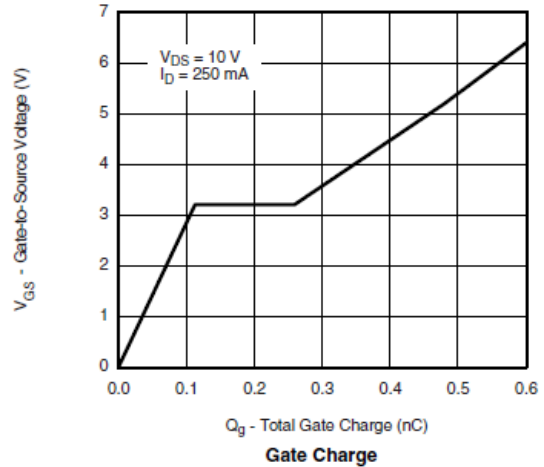
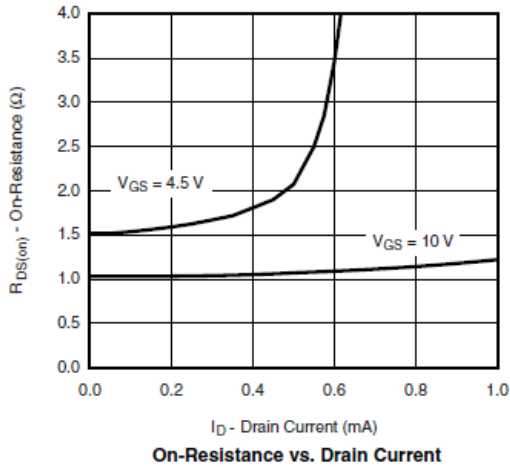
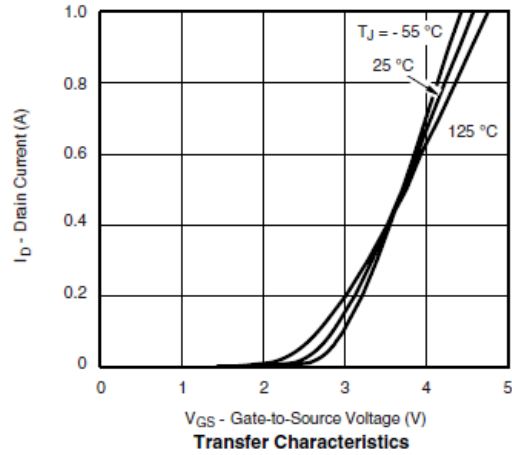
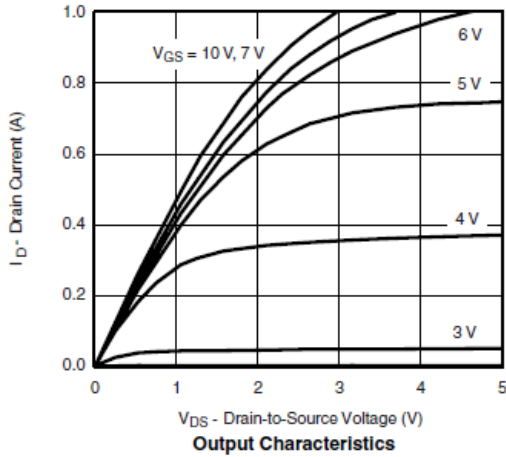



Typical Characteristics

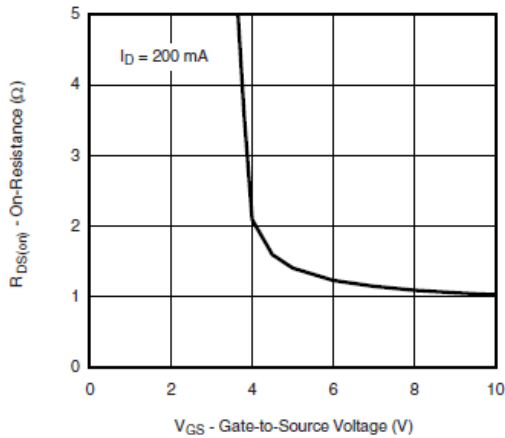

On-Resistance vs. Gate-Source Voltage

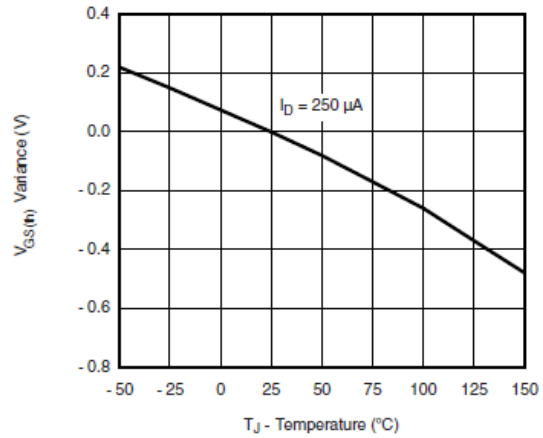

Threshold Voltage Variance over Temperature

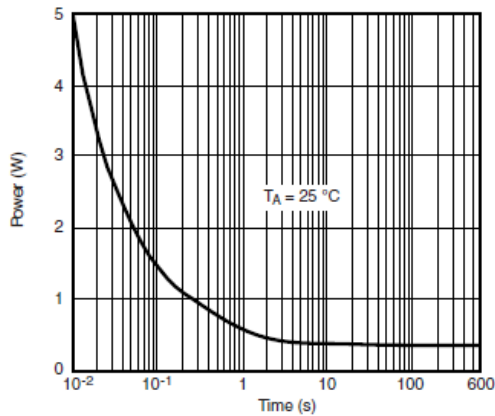

Single Pulse Power

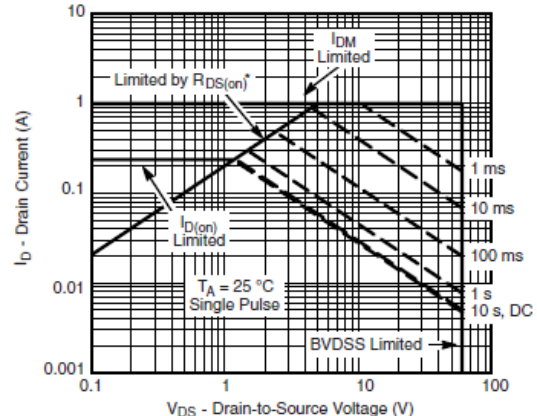

Safe Operating Area
* $V_{GS} >$ minimum V_{GS} at which $R_{DS(on)}$ is specified

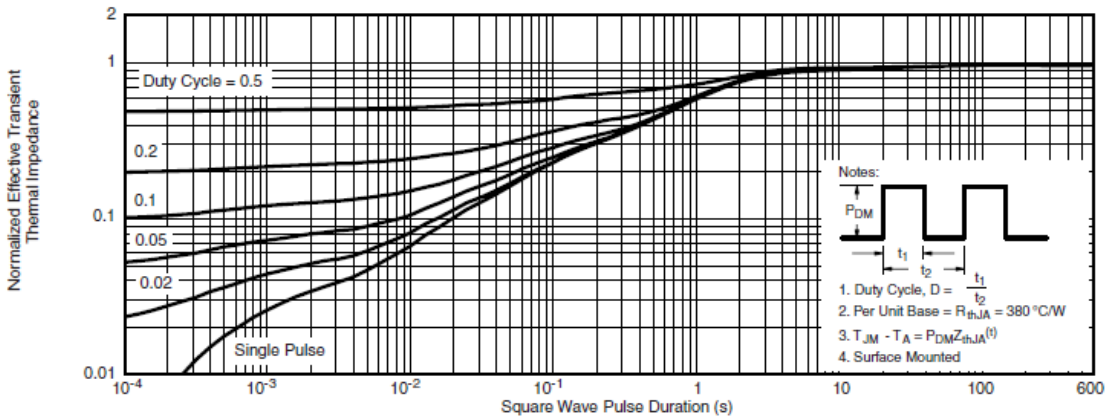

Normalized Thermal Transient Impedance, Junction-to-Ambient



Typical Characteristics

Gate Charge Test Circuit & Waveform

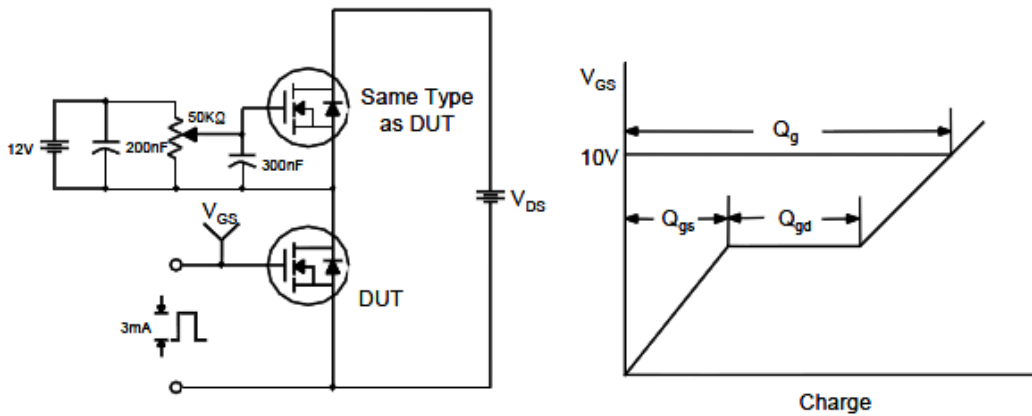

Resistive Switching Test Circuit & Waveforms

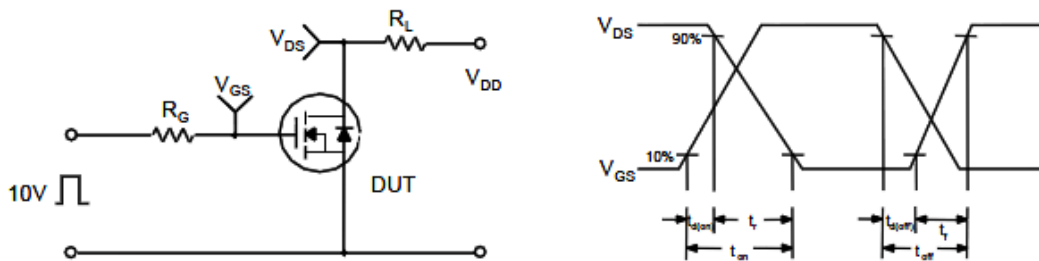

Unclamped Inductive Switching Test Circuit & Waveforms

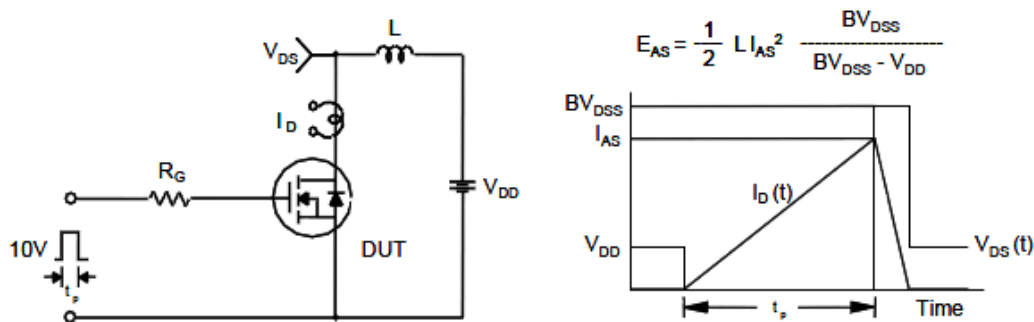



Package Information (SOT-323)

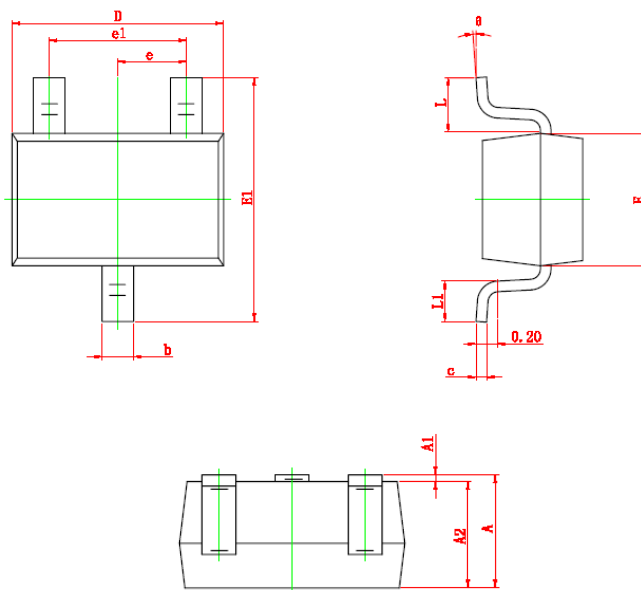

Symbol	Dimensions In Millimeters		Dimensions In Inches	
	Min	Max	Min	Max
A	0.900	1.100	0.035	0.043
A1	0.000	0.100	0.000	0.004
A2	0.900	1.000	0.035	0.039
b	0.200	0.400	0.008	0.016
c	0.080	0.150	0.003	0.006
D	2.000	2.200	0.079	0.087
E	1.150	1.350	0.045	0.053
E1	2.150	2.450	0.085	0.096
e	0.650 TYP		0.026 TYP	
e1	1.200	1.400	0.047	0.055
L	0.525 REF		0.021 REF	
L1	0.260	0.460	0.010	0.018
θ	0°	8°	0°	8°

©2010 Alfa-MOS Technology Corp.
2F, No.80, Sec.1, Cheng Kung Rd., Nan Kang Dist., Taipei City 115, Taiwan (R.O.C.)
Tel : 886 2) 2651 3928
Fax : 886 2) 2786 8483
©http://www.alfa-mos.com