



General Description

AFN5904W, N-Channel enhancement mode MOSFET, uses Advanced Trench Technology to provide excellent $R_{DS(ON)}$, low gate charge.

These devices are particularly suited for low voltage power management, such as smart phone and notebook computer and other battery powered circuits, and low in-line power loss are needed in commercial industrial surface mount applications.

Features

- $I_D=4.5A, R_{DS(ON)}=50m\Omega@V_{GS}=4.5V$
- $I_D=3.6A, R_{DS(ON)}=60m\Omega@V_{GS}=2.5V$
- $I_D=2.4A, R_{DS(ON)}=78m\Omega@V_{GS}=1.8V$
- Super high density cell design for extremely low $R_{DS(ON)}$
- Exceptional on-resistance and maximum DC current capability
- DFN3X2-8L package design

Pin Description (DFN3X2-8L)

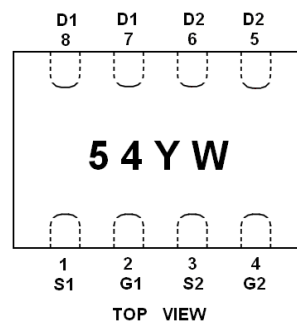
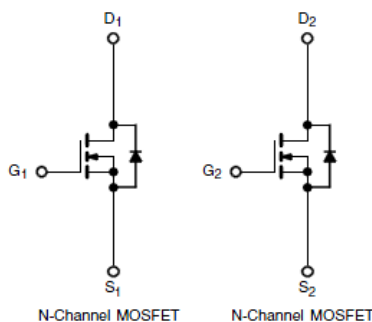
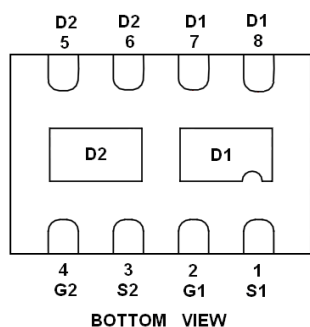

Application

- Load Switch
- PA Switch
- Battery Switch

Pin Define

Pin	Symbol	Description
1	S1	Source 1
2	G1	Gate 1
3	S2	Source 2
4	G2	Gate 2
5	D2	Drain 2
6	D2	Drain 2
7	D1	Drain 1
8	D1	Drain 1

Ordering Information

Part Ordering No.	Part Marking	Package	Unit	Quantity
AFN5904WFN328RG	54YW	DFN3X2-8L	Tape & Reel	4000 EA

※ Y year code

※ W weekh code

※ AFN5904WFN328RG : 7" Tape & Reel ; Pb- Free ; Halogen -Free



Absolute Maximum Ratings

(T_A=25°C Unless otherwise noted)

Parameter	Symbol	Value	Unit
Drain-Source Voltage	V _{DSS}	20	V
Gate –Source Voltage	V _{GSS}	±12	V
Continuous Drain Current(T _J =150°C)	I _D	T _A =25°C	4.5
		T _A =70°C	2.4
Pulsed Drain Current	I _{DM}	20	A
Continuous Source Current(Diode Conduction)	I _S	1.6	A
Power Dissipation	P _D	T _A =25°C	6.5
		T _A =70°C	4.2
Operating Junction Temperature	T _J	150	°C
Storage Temperature Range	T _{STG}	-55/150	°C
Thermal Resistance-Junction to Ambient	R _{θJA}	120	°C/W

Electrical Characteristics

(T_A=25°C Unless otherwise noted)

Parameter	Symbol	Conditions	Min.	Typ	Max.	Unit
Static						
Drain-Source Breakdown Voltage	V _{(BR)DSS}	V _{GS} =0V, I _D =250uA	20			V
Gate Threshold Voltage	V _{GS(th)}	V _{DS} =V _{GS} , I _D =250uA	0.3		0.8	
Gate Leakage Current	I _{GSS}	V _{DS} =0V, V _{GS} =±12V			±100	nA
Zero Gate Voltage Drain Current	I _{DSS}	V _{DS} =16V, V _{GS} =0V			1	uA
		V _{DS} =16V, V _{GS} =0V T _J =85°C			10	
On-State Drain Current	I _{D(on)}	V _{DS} ≥ 5V, V _{GS} =4.5V	6			A
		V _{DS} ≥ 5V, V _{GS} =2.5V	4			
Drain-Source On-Resistance	R _{DS(on)}	V _{GS} =4.5V, I _D =4.5A		46	50	mΩ
		V _{GS} =2.5V, I _D =3.6A		54	60	
		V _{GS} =1.8V, I _D =2.4A		67	78	
Forward Transconductance	g _{FS}	V _{DS} =5V, I _D =3.6A		10		S
Diode Forward Voltage	V _{SD}	I _S =1.6A, V _{GS} =0V		0.85	1.2	V
Dynamic						
Total Gate Charge	Q _g	V _{DS} =10V, V _{GS} =4.5V I _D ≧3.6A		4.2	5.0	nC
Gate-Source Charge	Q _{gs}			0.6		
Gate-Drain Charge	Q _{gd}			0.4		
Input Capacitance	C _{iss}	V _{DS} =10V, V _{GS} =0V f=1MHz		340		pF
Output Capacitance	C _{oss}			115		
Reverse Transfer Capacitance	C _{rss}			33		
Turn-On Time	t _{d(on)}	V _{DD} =10V, R _L =2.8Ω I _D ≧3.6A, V _{GEN} =4.5V R _G =1Ω		8	15	ns
	t _r			8	15	
Turn-Off Time	t _{d(off)}			25	40	
	t _f			8	15	



Typical Characteristics

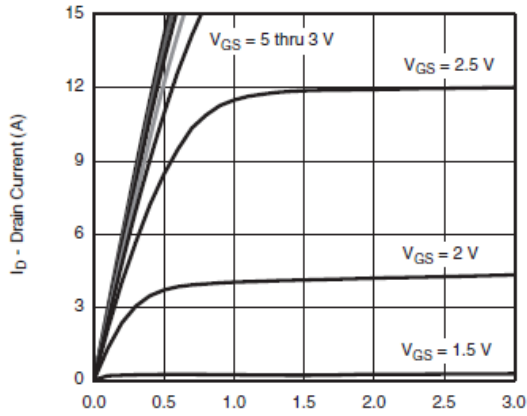

Output Characteristics

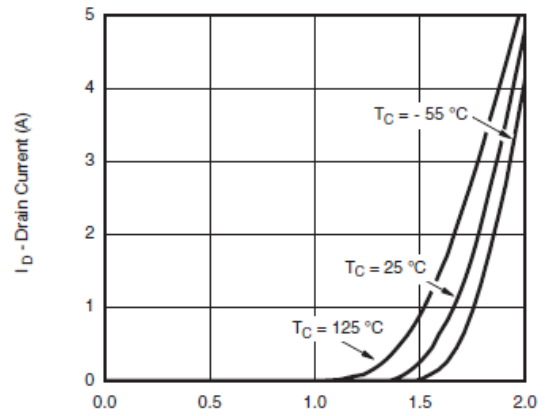

Transfer Characteristics

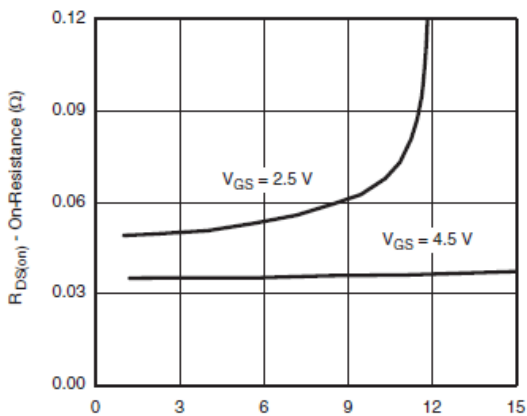

On-Resistance vs. Drain Current and Gate Voltage

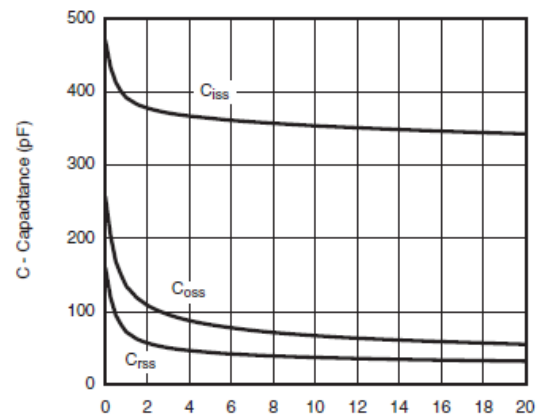

Capacitance

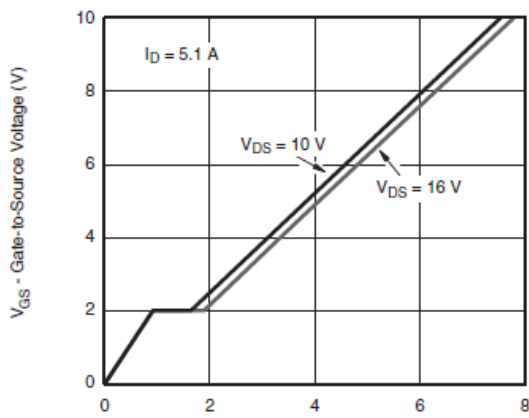

Gate Charge

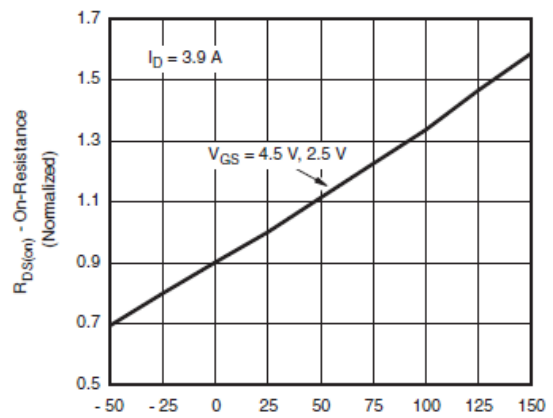

On-Resistance vs. Junction Temperature



Typical Characteristics

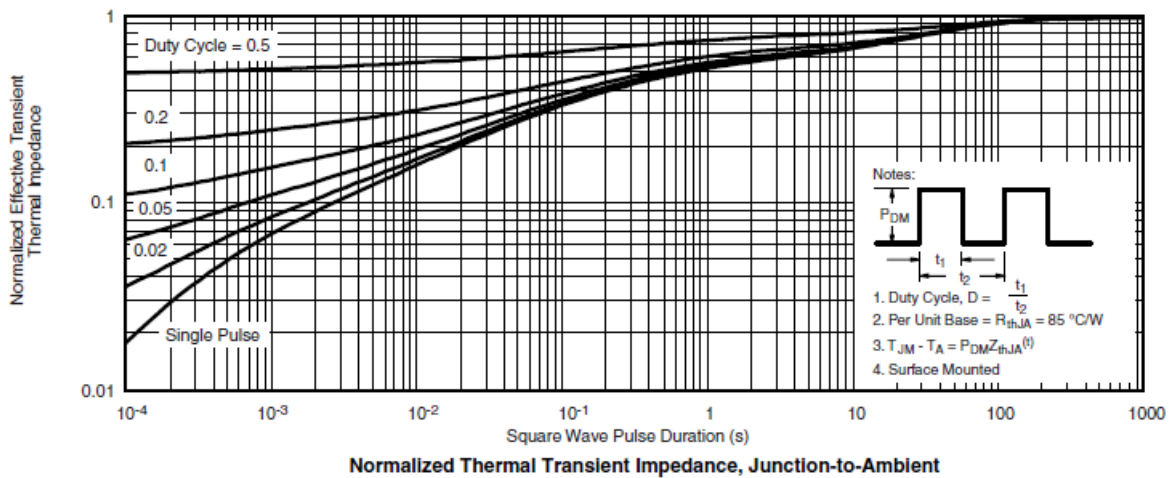
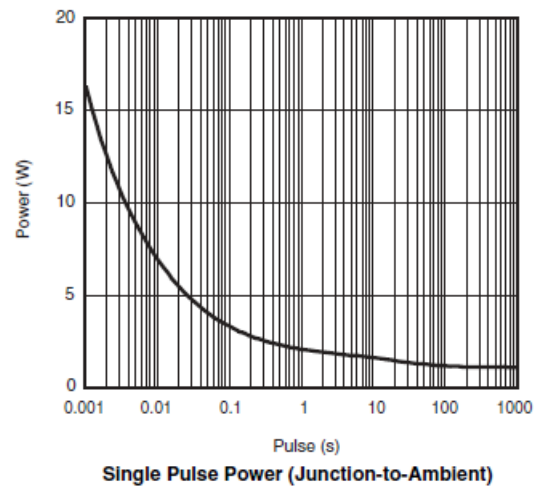
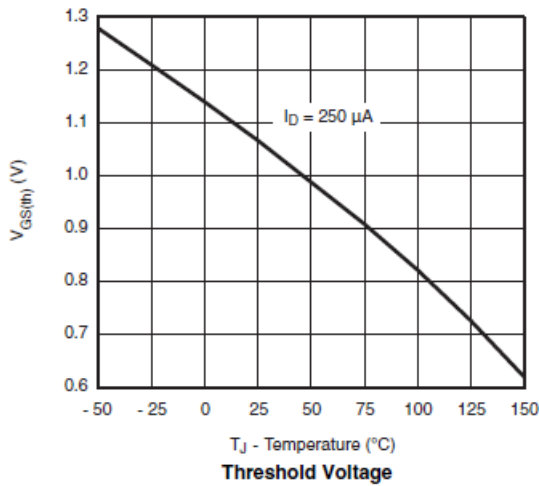
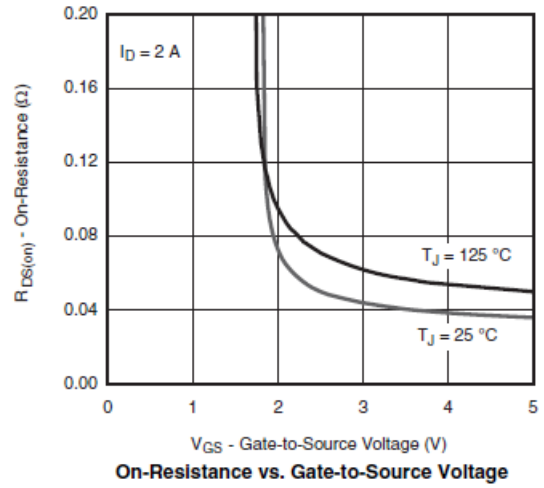
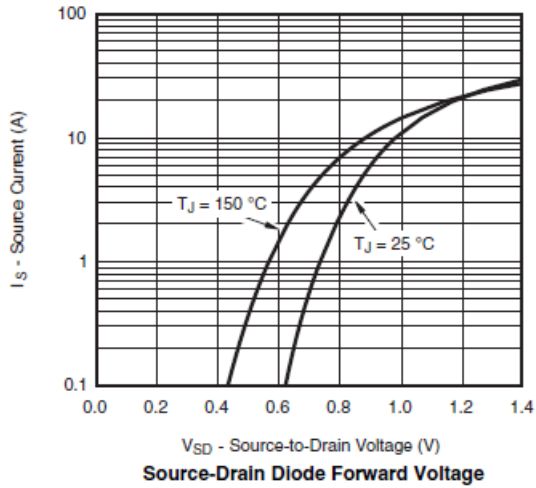



Typical Characteristics

Gate Charge Test Circuit & Waveform



Resistive Switching Test Circuit & Waveforms



Unclamped Inductive Switching Test Circuit & Waveforms





Package Information (DFN3X2-8L)

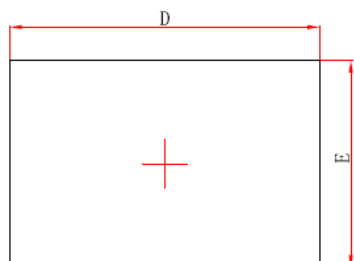

Top View

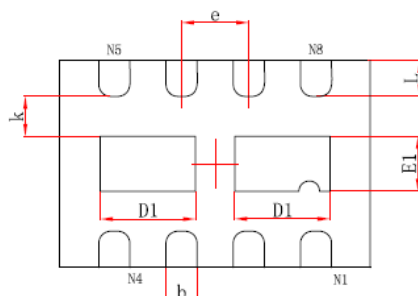

Bottom View

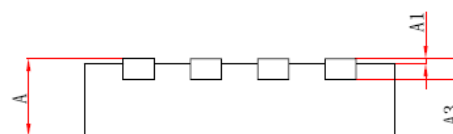

Side View

Symbol	Dimensions In Millimeters		Dimensions In Inches	
	Min.	Max.	Min.	Max.
A	0.700/0.800	0.800/0.900	0.028/0.031	0.031/0.035
A1	0.000	0.050	0.000	0.002
A3	0.203REF.		0.008REF.	
D	2.924	3.076	0.115	0.121
E	1.924	2.076	0.076	0.082
D1	0.820	1.020	0.032	0.040
E1	0.430	0.630	0.017	0.025
k	0.200MIN.		0.008MIN.	
b	0.250	0.350	0.010	0.014
e	0.650TYP.		0.026TYP.	
L	0.274	0.426	0.011	0.017

©2010 Alfa-MOS Technology Corp.
2F, No.80, Sec.1, Cheng Kung Rd., Nan Kang Dist., Taipei City 115, Taiwan (R.O.C.)
Tel : 886 2) 2651 3928
Fax : 886 2) 2786 8483
©http://www.alfa-mos.com