



### General Description

AFN6018S, N-Channel enhancement mode MOSFET, uses Advanced Trench Technology to provide excellent  $R_{DS(ON)}$ , low gate charge.

These devices are particularly suited for low voltage power management, and low in-line power loss are needed in commercial industrial surface mount applications.

### Features

- 60V/25A,  $R_{DS(ON)} = 15m\Omega @ V_{GS} = 10V$
- 60V/15A,  $R_{DS(ON)} = 18m\Omega @ V_{GS} = 4.5V$
- Super high density cell design for extremely low  $R_{DS(ON)}$
- TO-220-3L package design

### Pin Description ( TO-220-3L )

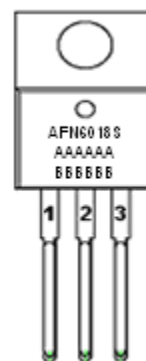
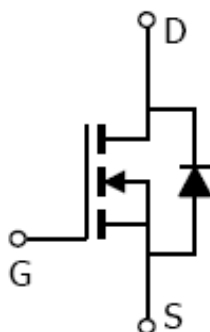
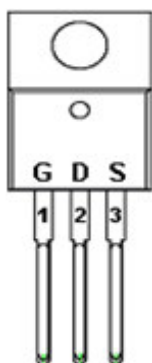

### Application

- Synchronous Rectifier
- Power Supplies

### Pin Define

| Pin | Symbol | Description |
|-----|--------|-------------|
| 1   | G      | Gate        |
| 2   | D      | Drain       |
| 3   | S      | Source      |

### Ordering Information

| Part Ordering No. | Part Marking                 | Package   | Unit | Quantity |
|-------------------|------------------------------|-----------|------|----------|
| AFN6018ST220TG    | AFN6018S<br>AAAAAA<br>BBBBBB | TO-220-3L | Tube | 50 EA    |

- ※ A Lot code
- ※ B Date code
- ※ AFN6018ST220TG : Tube ; Pb- Free ; Halogen- Free



### Absolute Maximum Ratings

(T<sub>A</sub>=25°C Unless otherwise noted)

| Parameter                                       | Symbol           | Typical              | Unit |
|---|------------------|----------------------|------|
| Drain-Source Voltage                            | V <sub>DSS</sub> | 60                   | V    |
| Gate –Source Voltage                            | V <sub>GSS</sub> | ±20                  | V    |
| Continuous Drain Current(T <sub>J</sub> =150°C) | I <sub>D</sub>   | T <sub>A</sub> =25°C | 40   |
|   |                  | T <sub>A</sub> =70°C | 20   |
| Pulsed Drain Current                            | I <sub>DM</sub>  | 60                   | A    |
| Continuous Source Current(Diode Conduction)     | I <sub>S</sub>   | 30                   |      |
| Single Pulse Avalanche Current                  | I <sub>AS</sub>  | 20                   |      |
| Power Dissipation                               | P <sub>D</sub>   | 95                   | W    |
| Operating Junction Temperature                  | T <sub>J</sub>   | 150                  | °C   |
| Storage Temperature Range                       | T <sub>STG</sub> | -55/150              | °C   |
| Thermal Resistance-Junction to Ambient          | R <sub>θJA</sub> | 62.5                 | °C/W |

### Electrical Characteristics

(T<sub>A</sub>=25°C Unless otherwise noted)

| Parameter                       | Symbol               | Conditions   | Min. | Typ  | Max. | Unit |
|---------------------------------|----------------------|--|------|------|------|------|
| <b>Static</b>                   |                      |  |      |      |      |      |
| Drain-Source Breakdown Voltage  | V <sub>(BR)DSS</sub> | V <sub>GS</sub> =0V, I <sub>D</sub> =250uA   | 60   |      |      | V    |
| Gate Threshold Voltage          | V <sub>GS(th)</sub>  | V <sub>DS</sub> =V <sub>GS</sub> , I <sub>D</sub> =250uA   | 1.0  |      | 2.0  |      |
| Gate Leakage Current            | I <sub>GSS</sub>     | V <sub>DS</sub> =0V, V <sub>GS</sub> =±20V   |      |      | ±100 | nA   |
| Zero Gate Voltage Drain Current | I <sub>DSS</sub>     | V <sub>DS</sub> =48V, V <sub>GS</sub> =0V  |      |      | 1    | uA   |
|                                 |                      | V <sub>DS</sub> =48V, V <sub>GS</sub> =0V<br>T <sub>J</sub> =85°C  |      |      | 30   |      |
| On-State Drain Current          | I <sub>D(on)</sub>   | V <sub>DS</sub> ≥ 10V, V <sub>GS</sub> =10V  | 25   |      |      | A    |
| Drain-Source On-Resistance      | R <sub>DS(on)</sub>  | V <sub>GS</sub> =10V, I <sub>D</sub> =25A  |      | 11   | 15   | mΩ   |
|                                 |                      | V <sub>GS</sub> =4.5V, I <sub>D</sub> =15A   |      | 13   | 18   |      |
| Forward Transconductance        | g <sub>FS</sub>      | V <sub>DS</sub> =15V, I <sub>D</sub> =10A  |      | 35   |      | S    |
| Diode Forward Voltage           | V <sub>SD</sub>      | I <sub>S</sub> =20A, V <sub>GS</sub> =0V   |      | 0.8  | 1.3  | V    |
| <b>Dynamic</b>                  |                      |  |      |      |      |      |
| Total Gate Charge               | Q <sub>g</sub>       | V <sub>DS</sub> =10V, V <sub>GS</sub> =10V<br>I <sub>D</sub> ≧10A  |      | 30   | 45   | nC   |
| Gate-Source Charge              | Q <sub>gs</sub>      |  |      | 7    |      |      |
| Gate-Drain Charge               | Q <sub>gd</sub>      |  |      | 6    |      |      |
| Input Capacitance               | C <sub>iss</sub>     | V <sub>DS</sub> =30V, V <sub>GS</sub> =0V<br>f=1MHz  |      | 1200 |      | pF   |
| Output Capacitance              | C <sub>oss</sub>     |  |      | 150  |      |      |
| Reverse Transfer Capacitance    | C <sub>rss</sub>     |  |      | 80   |      |      |
| Turn-On Time                    | t <sub>d(on)</sub>   | V <sub>DD</sub> =30V, R <sub>L</sub> =30Ω<br>I <sub>D</sub> ≧1A, V <sub>GEN</sub> =10V<br>R <sub>G</sub> =6.0Ω |      | 12   | 25   | ns   |
|                                 | t <sub>r</sub>       |  |      | 12   | 20   |      |
| Turn-Off Time                   | t <sub>d(off)</sub>  |  |      | 50   | 80   |      |
|                                 | t <sub>f</sub>       |  |      | 12   | 20   |      |



## Typical Characteristics

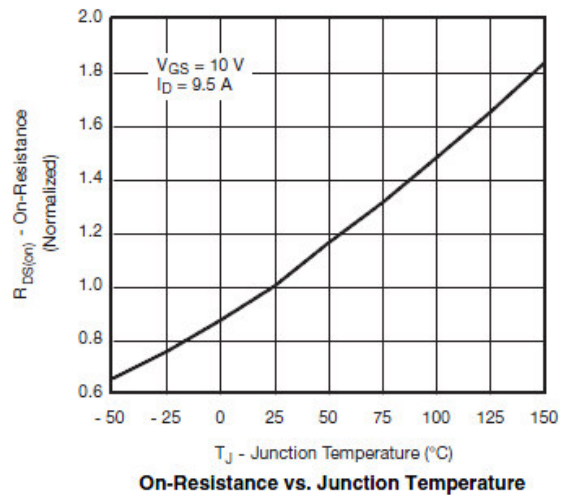
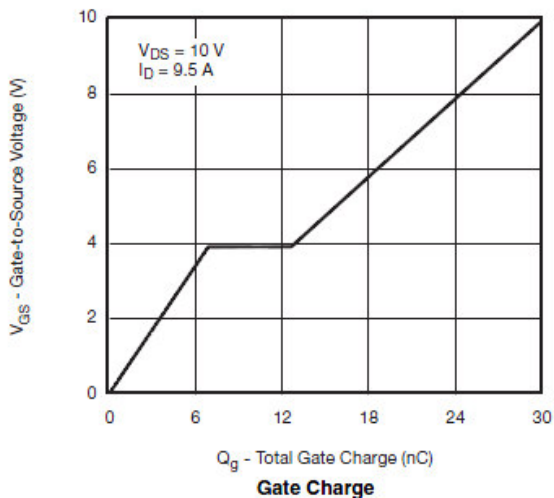
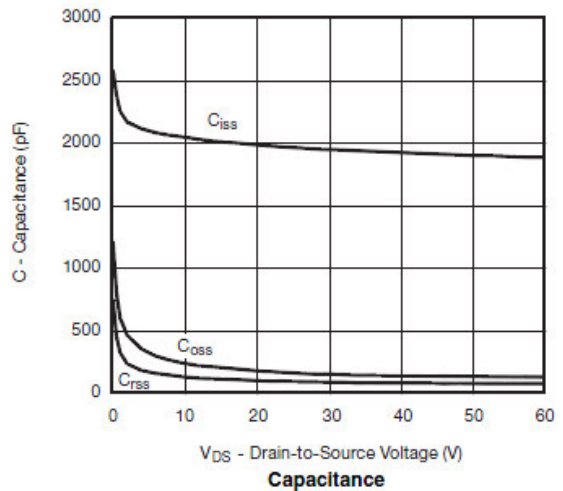
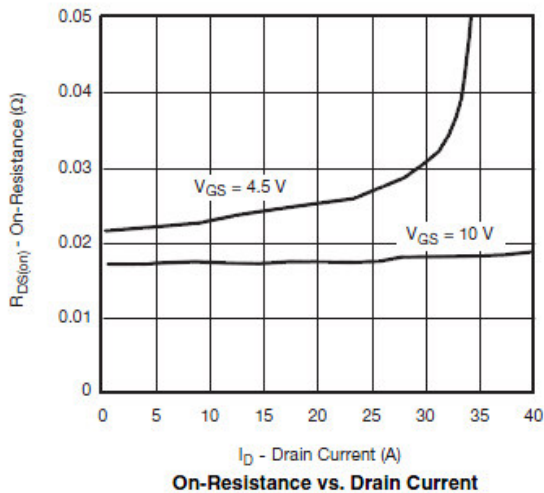
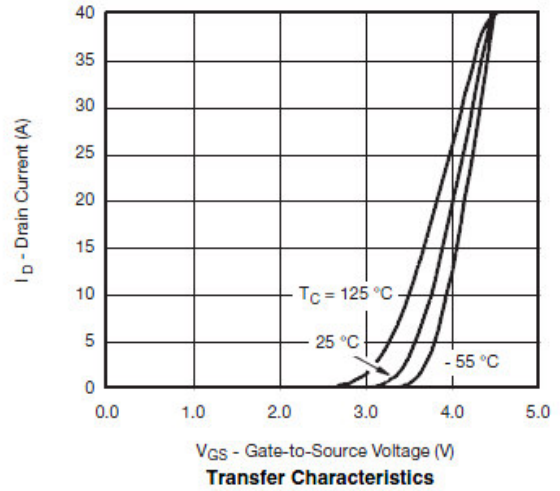
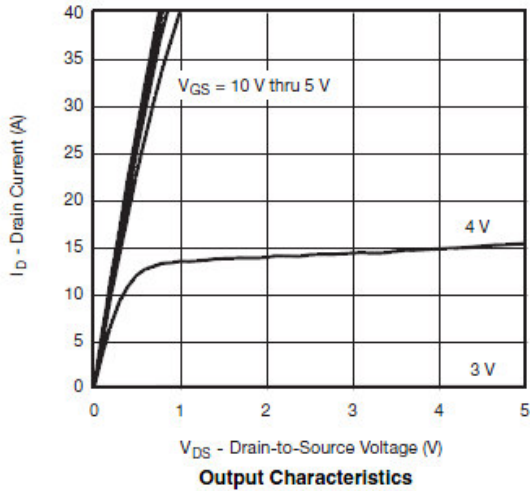



## Typical Characteristics

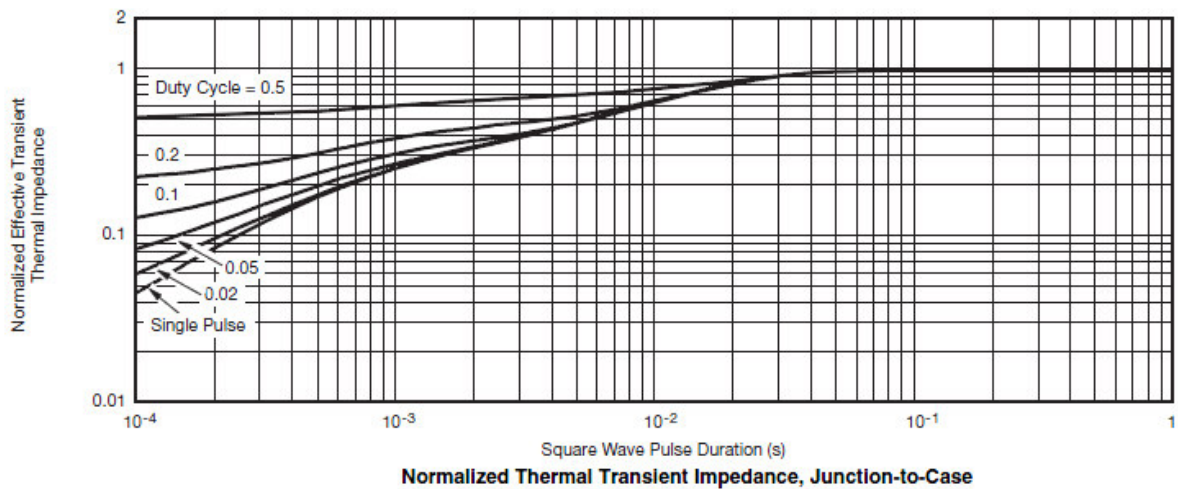
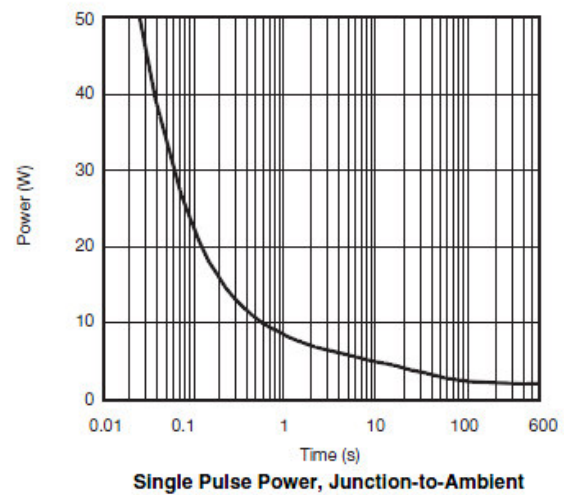
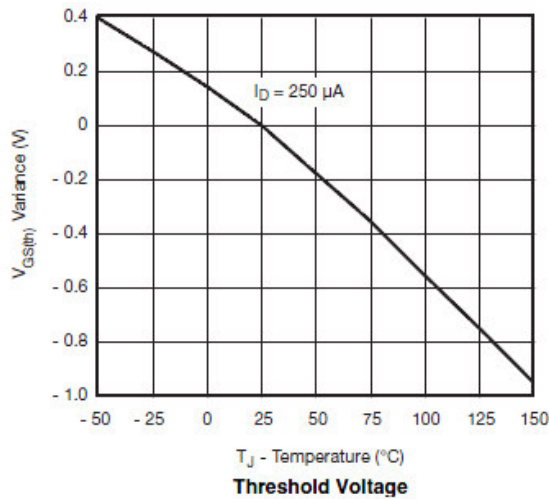
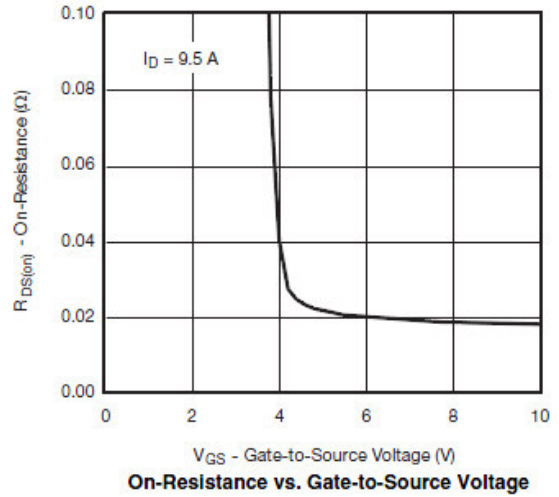
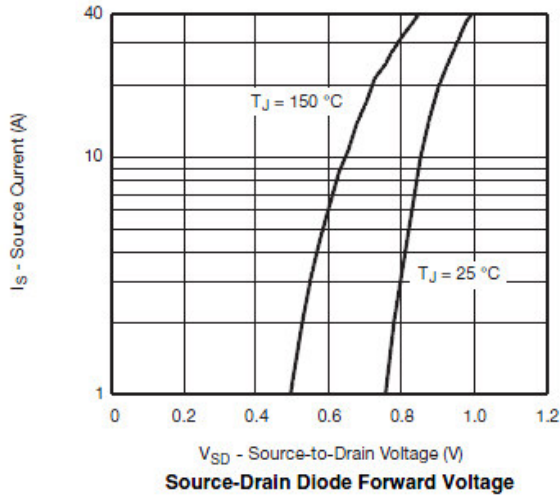



**Typical Characteristics**

Gate Charge Test Circuit & Waveform



Resistive Switching Test Circuit & Waveforms



Unclamped Inductive Switching Test Circuit & Waveforms





**Package Information ( TO-220-3L )**

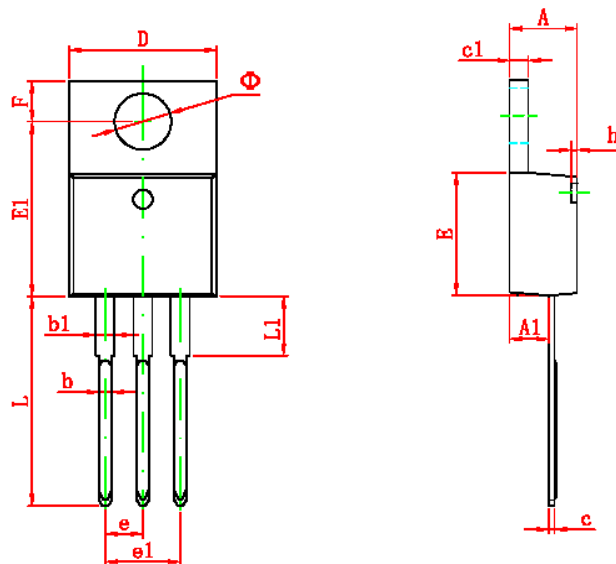

| Symbol | Dimensions In Millimeters |        | Dimensions In Inches |       |
|--------|---------------------------|--------|----------------------|-------|
|        | Min                       | Max    | Min                  | Max   |
| A      | 4.470                     | 4.670  | 0.176                | 0.184 |
| A1     | 2.520                     | 2.820  | 0.099                | 0.111 |
| b      | 0.710                     | 0.910  | 0.028                | 0.036 |
| b1     | 1.170                     | 1.370  | 0.046                | 0.054 |
| c      | 0.310                     | 0.530  | 0.012                | 0.021 |
| c1     | 1.170                     | 1.370  | 0.046                | 0.054 |
| D      | 10.010                    | 10.310 | 0.394                | 0.406 |
| E      | 8.500                     | 8.900  | 0.335                | 0.350 |
| E1     | 12.060                    | 12.460 | 0.475                | 0.491 |
| e      | 2.540 TYP                 |        | 0.100 TYP            |       |
| e1     | 4.980                     | 5.180  | 0.196                | 0.204 |
| F      | 2.590                     | 2.890  | 0.102                | 0.114 |
| h      | 0.000                     | 0.300  | 0.000                | 0.012 |
| L      | 13.400                    | 13.800 | 0.528                | 0.543 |
| L1     | 3.560                     | 3.960  | 0.140                | 0.156 |
| • •    | 3.735                     | 3.935  | 0.147                | 0.155 |

©2010 Alfa-MOS Technology Corp.  
 2F, No.80, Sec.1, Cheng Kung Rd., Nan Kang Dist., Taipei City 115, Taiwan (R.O.C.)  
 Tel : 886 2) 2651 3928  
 Fax : 886 2) 2786 8483  
 ©http://www.alfa-mos.com