



General Description

AFN6035S, N-Channel enhancement mode MOSFET, uses Advanced Trench Technology to provide excellent $R_{DS(ON)}$, low gate charge.

These devices are particularly suited for low voltage power management, and low in-line power loss are needed in commercial industrial surface mount applications.

Features

- 60V/40A, $R_{DS(ON)} = 4.5m\Omega @ V_{GS} = 10V$
- 60V/30A, $R_{DS(ON)} = 5.5m\Omega @ V_{GS} = 6.0V$
- 60V/20A, $R_{DS(ON)} = 7.2m\Omega @ V_{GS} = 4.5V$
- Super high density cell design for extremely low $R_{DS(ON)}$
- TO-220-3L package design

Pin Description (TO-220-3L)

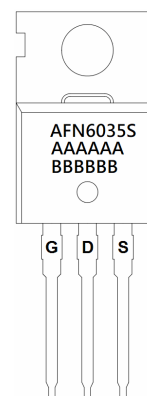
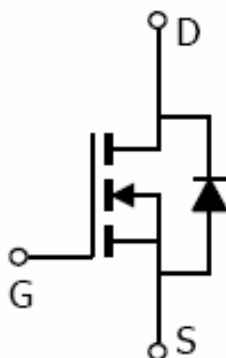
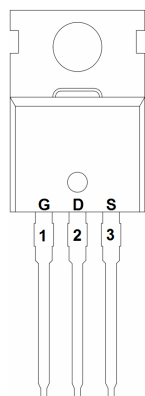

Application

- Synchronous Rectifier
- Power Supplies

Pin Define

Pin	Symbol	Description
1	G	Gate
2	D	Drain
3	S	Source

Ordering Information

Part Ordering No.	Part Marking	Package	Unit	Quantity
AFN6035ST220TG	AFN6035S AAAAAA BBBBBB	TO-220-3L	Tube	50 EA

- ※ A Lot code
- ※ B Date code
- ※ AFN6035ST220TG : Tube ; Pb- Free ; Halogen –Free



Absolute Maximum Ratings

(T_A=25°C Unless otherwise noted)

Parameter	Symbol	Typical	Unit
Drain-Source Voltage	V _{DSS}	60	V
Gate –Source Voltage	V _{GSS}	±20	V
Continuous Drain Current(T _J =150°C)	I _D	T _A =25°C	80
		T _A =70°C	40
Pulsed Drain Current	I _{DM}	160	A
Continuous Source Current(Diode Conduction)	I _S	80	
Single Pulse Avalanche Current	I _{AS}	40	
Power Dissipation	P _D	95	W
Operating Junction Temperature	T _J	150	°C
Storage Temperature Range	T _{STG}	-55/150	°C
Thermal Resistance-Junction to Ambient	R _{θJA}	62.5	°C/W

Electrical Characteristics

(T_A=25°C Unless otherwise noted)

Parameter	Symbol	Conditions	Min.	Typ	Max.	Unit
Static						
Drain-Source Breakdown Voltage	V _{(BR)DSS}	V _{GS} =0V, I _D =250uA	60			V
Gate Threshold Voltage	V _{GS(th)}	V _{DS} =V _{GS} , I _D =250uA	1.0		2.5	
Gate Leakage Current	I _{GSS}	V _{DS} =0V, V _{GS} =±20V			±100	nA
Zero Gate Voltage Drain Current	I _{DSS}	V _{DS} =48V, V _{GS} =0V			1	uA
		V _{DS} =48V, V _{GS} =0V T _J =85°C			30	
On-State Drain Current	I _{D(on)}	V _{DS} ≥ 5V, V _{GS} =10V	40			A
Drain-Source On-Resistance	R _{DS(on)}	V _{GS} =10V, I _D =40A		3.85	4.5	mΩ
		V _{GS} =6.0V, I _D =30A		4.85	5.5	
		V _{GS} =4.5V, I _D =20A		6.2	7.2	
Forward Transconductance	g _{FS}	V _{DS} =15V, I _D =20A		80		S
Diode Forward Voltage	V _{SD}	I _S =20A, V _{GS} =0V		0.8	1.3	V
Dynamic						
Total Gate Charge	Q _g	V _{DS} =30V, V _{GS} =4.5V I _D ≅10A		18	35	nC
Gate-Source Charge	Q _{gs}			8		
Gate-Drain Charge	Q _{gd}			5		
Input Capacitance	C _{iss}	V _{DS} =30V, V _{GS} =0V f=1MHz		2805		pF
Output Capacitance	C _{oss}			1050		
Reverse Transfer Capacitance	C _{rss}			85		
Turn-On Time	t _{d(on)}	V _{DD} =30V, R _L =30Ω I _D ≅10A, V _{GEN} =10V		20	40	ns
	t _r			10	20	
Turn-Off Time	t _{d(off)}	R _G =1Ω		30	60	
	t _f			10	20	



Typical Characteristics

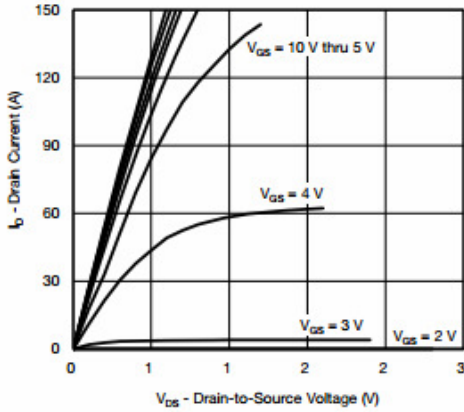

Output Characteristics

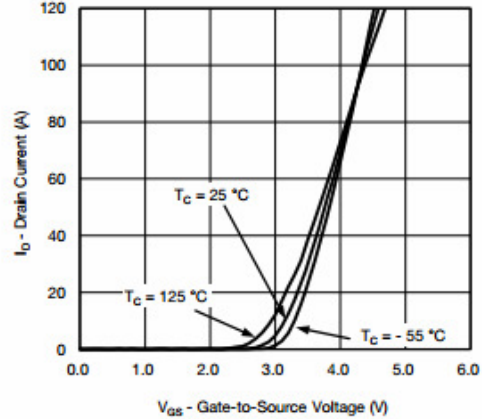

Transfer Characteristics

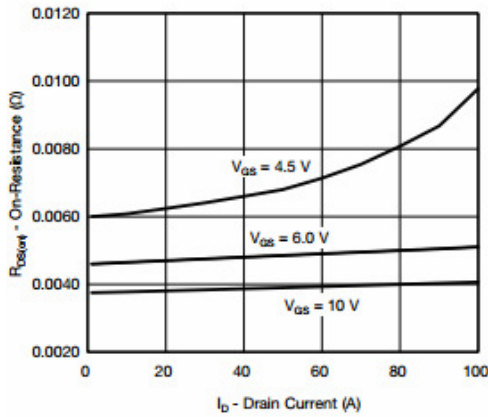

On-Resistance vs. Drain Current

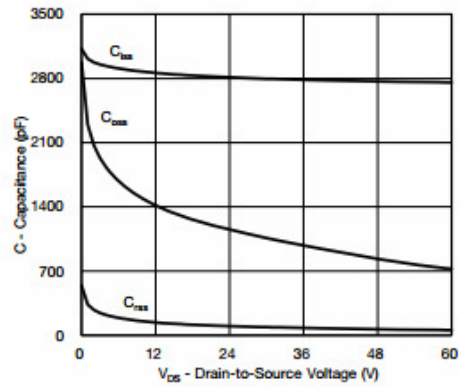

Capacitance

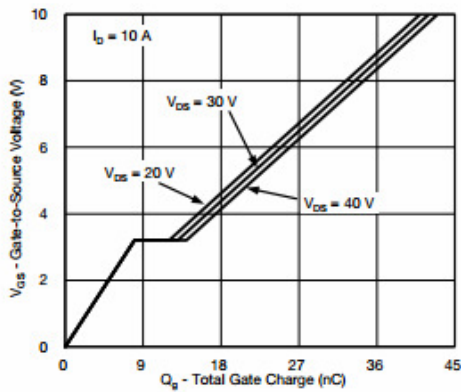

Gate Charge

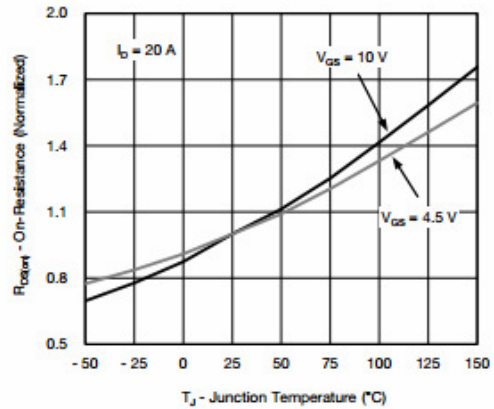

On-Resistance vs. Junction Temperature



Typical Characteristics

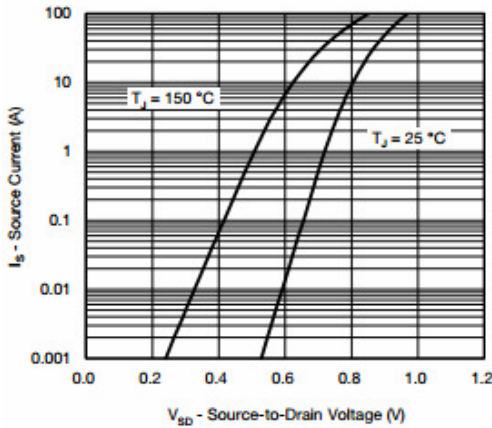

Source-Drain Diode Forward Voltage

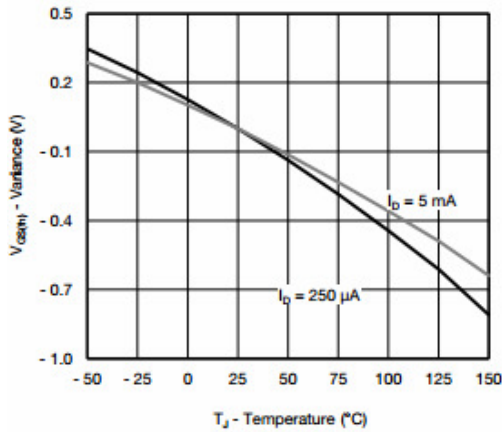

Threshold Voltage

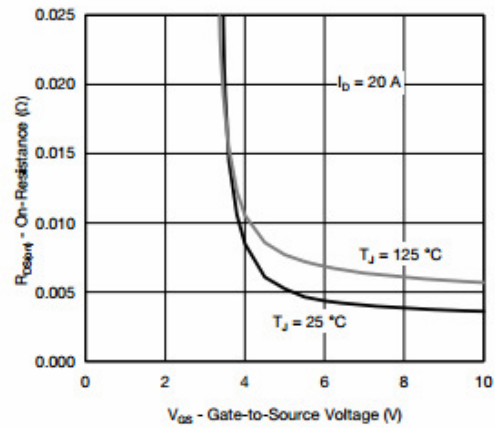

On-Resistance vs. Gate-to-Source Voltage

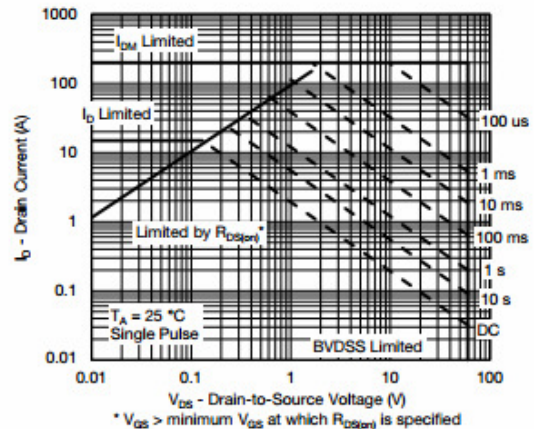

Safe Operating Area, Junction-to-Ambient

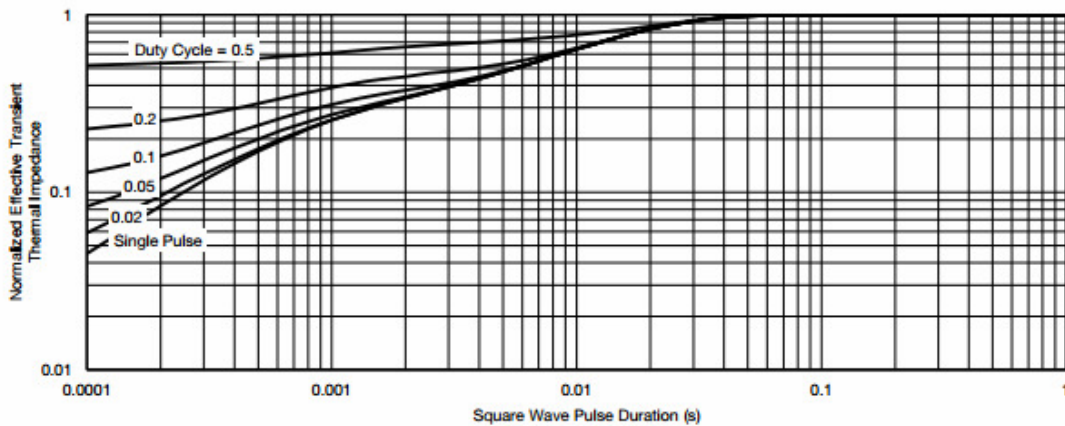

Normalized Thermal Transient Impedance, Junction-to-Case



Typical Characteristics

Gate Charge Test Circuit & Waveform

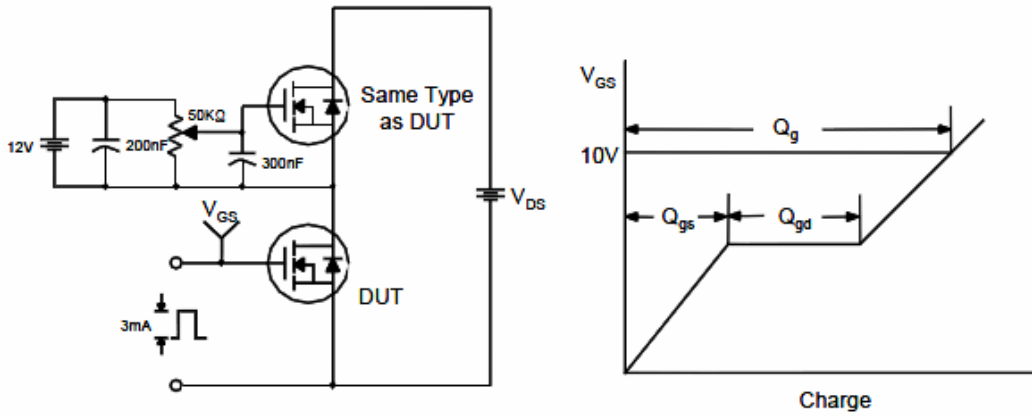

Resistive Switching Test Circuit & Waveforms

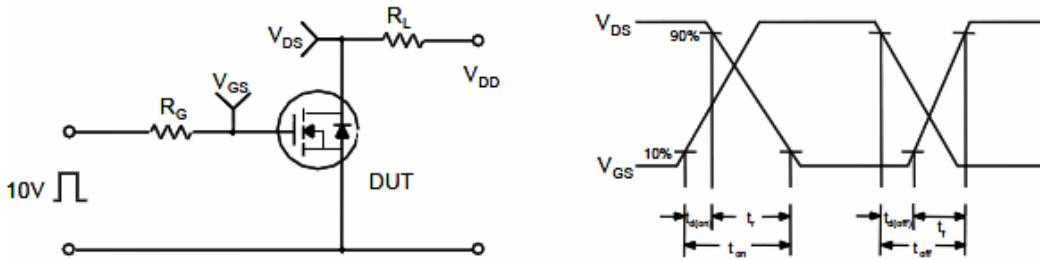

Unclamped Inductive Switching Test Circuit & Waveforms

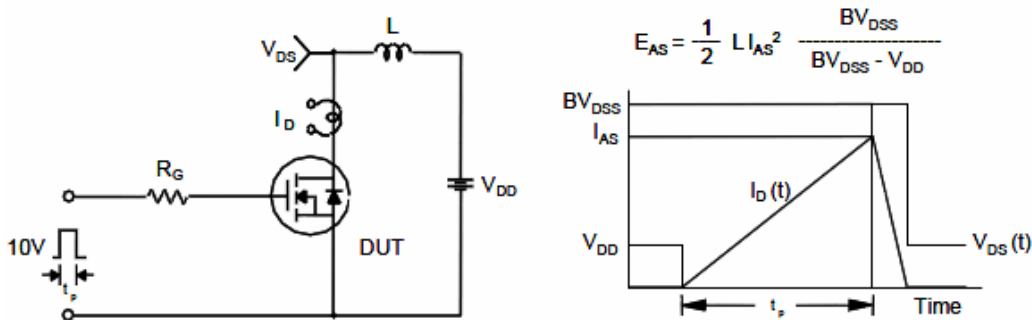



Package Information (TO-220-3L)

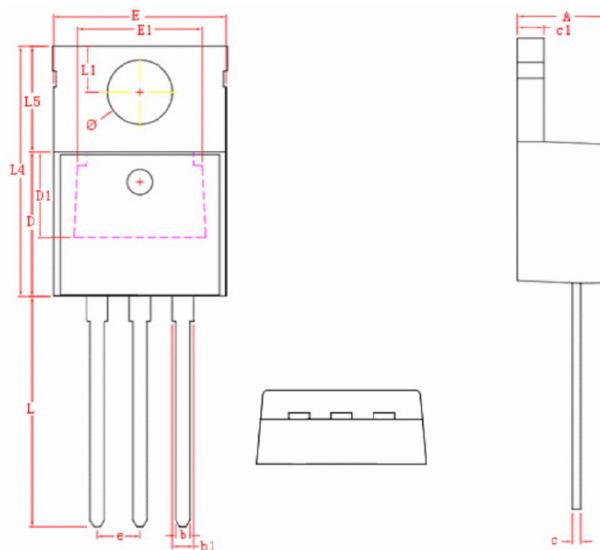

COMMON DIMENSIONS
(UNITS OF MEASURE=MILLIMETER)

SYMBOL	MIN	NOM	MAX
A	4.40	4.60	4.80
b	0.76	0.88	1.00
D	8.60	8.80	9.00
c	0.36	0.43	0.50
E	9.80	10.10	10.40
L4	14.70	15.00	15.30
L5	6.20	6.40	6.60
D1	5.10 REF.		
c1	1.25	1.35	1.45
b1	1.17	1.32	1.47
L	13.25	13.75	14.25
e	2.54 REF.		
L1	2.60	2.75	2.89
∅	3.71	3.84	3.96
E1	7.40 REF.		

©2010 Alfa-MOS Technology Corp.
2F, No.80, Sec.1, Cheng Kung Rd., Nan Kang Dist., Taipei City 115, Taiwan (R.O.C.)
Tel : 886 2) 2651 3928
Fax : 886 2) 2786 8483
©http://www.alfa-mos.com