



### General Description

AFN6098S, N-Channel enhancement mode MOSFET, uses Advanced Trench Technology to provide excellent  $R_{DS(ON)}$ , low gate charge.

These devices are particularly suited for low voltage power management, and low in-line power loss are needed in commercial industrial surface mount applications.

### Features

- 60V/50A,  $R_{DS(ON)} = 4m\Omega @ V_{GS} = 10V$
- 60V/25A,  $R_{DS(ON)} = 6m\Omega @ V_{GS} = 6V$
- Super high density cell design for extremely low  $R_{DS(ON)}$
- TO-262 package design

### Pin Description ( TO-262 )

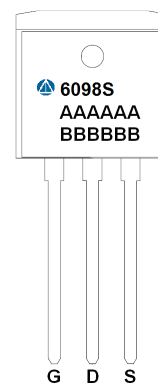
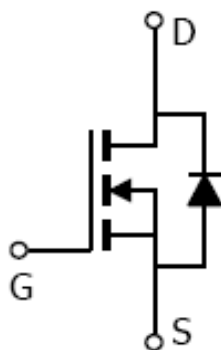
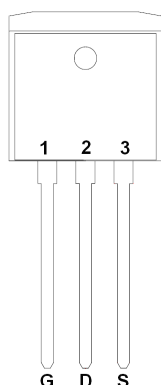

### Application

- Synchronous Rectifier
- Power Supplies

### Pin Define

Pin	Symbol	Description
1	G	Gate
2	D	Drain
3	S	Source

### Ordering Information

Part Ordering No.	Part Marking	Package	Unit	Quantity
AFN6098ST262TG	6098S AAAAAA BBBBBB	TO-262	Tube	50 EA

- ※ A Lot code
- ※ B Date code
- ※ AFN6098ST262TG : Tube ; Pb- Free ; Halogen –Free



### Absolute Maximum Ratings

( $T_A=25^\circ\text{C}$  Unless otherwise noted)

Parameter	Symbol	Value	Unit
Drain-Source Voltage	$V_{DSS}$	60	V
Gate-Source Voltage	$V_{GSS}$	$\pm 20$	V
Continuous Drain Current( $T_J=150^\circ\text{C}$ )	$I_D$	$T_C=25^\circ\text{C}$	90
		$T_C=70^\circ\text{C}$	45
Pulsed Drain Current	$I_{DM}$	150	A
Continuous Source Current(Diode Conduction)	$I_S$	80	
Single Pulse Avalanche Current	$I_{AS}$	40	
Power Dissipation	$P_D$	$T_C=25^\circ\text{C}$	100
		$T_A=25^\circ\text{C}$	3.1
Operating Junction Temperature	$T_J$	150	$^\circ\text{C}$
Storage Temperature Range	$T_{STG}$	-55/150	$^\circ\text{C}$
Thermal Resistance-Junction to Ambient	$R_{\theta JA}$	62.5	$^\circ\text{C/W}$

### Electrical Characteristics

( $T_A=25^\circ\text{C}$  Unless otherwise noted)

Parameter	Symbol	Conditions	Min.	Typ	Max.	Unit
<b>Static</b>						
Drain-Source Breakdown Voltage	$V_{(BR)DSS}$	$V_{GS}=0V, I_D=250\mu\text{A}$	60			V
Gate Threshold Voltage	$V_{GS(th)}$	$V_{DS}=V_{GS}, I_D=250\mu\text{A}$	2.0	3.0	4.0	
Gate Leakage Current	$I_{GSS}$	$V_{DS}=0V, V_{GS}=\pm 20V$			$\pm 100$	nA
Zero Gate Voltage Drain Current	$I_{DSS}$	$V_{DS}=48V, V_{GS}=0V$			1	uA
		$V_{DS}=48V, V_{GS}=0V$ $T_J=85^\circ\text{C}$			30	
On-State Drain Current	$I_{D(on)}$	$V_{DS} \geq 10V, V_{GS}=10V$	80			A
Drain-Source On-Resistance	$R_{DS(on)}$	$V_{GS}=10V, I_D=50A$		2.8	4	m $\Omega$
		$V_{GS}=6V, I_D=25A$		3.8	6	
Forward Transconductance	$g_{FS}$	$V_{DS}=10V, I_D=40A$		80		S
Diode Forward Voltage	$V_{SD}$	$I_S=30A, V_{GS}=0V$		0.8	1.3	V
<b>Dynamic</b>						
Total Gate Charge	$Q_g$	$V_{DS}=30V, V_{GS}=10V$ $I_D=20A$		100	150	nC
Gate-Source Charge	$Q_{gs}$			30		
Gate-Drain Charge	$Q_{gd}$			45		
Input Capacitance	$C_{iss}$	$V_{DS}=30V, V_{GS}=0V$ $f=1\text{MHz}$		3450	6500	pF
Output Capacitance	$C_{oss}$			1100		
Reverse Transfer Capacitance	$C_{rss}$			400		
Turn-On Time	$t_{d(on)}$	$V_{DD}=30V, R_L=1.5\Omega$ $I_D=20A, V_{GEN}=10V$ $R_G=3.0\Omega$		30	60	ns
	$t_r$			30	60	
Turn-Off Time	$t_{d(off)}$			40	80	
	$t_f$			15	30	



## Typical Characteristics

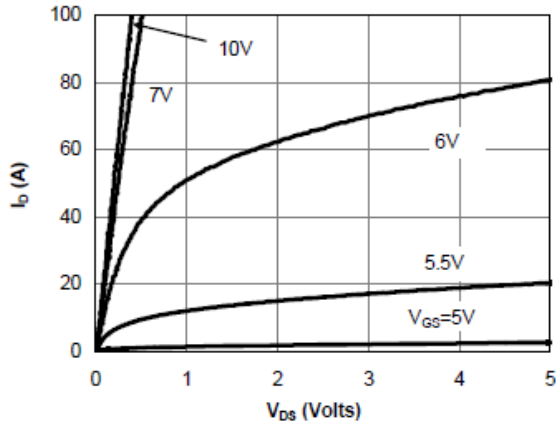

On-Region Characteristics

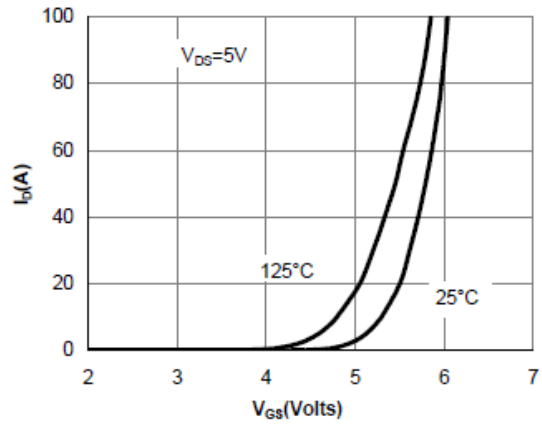

Transfer Characteristics

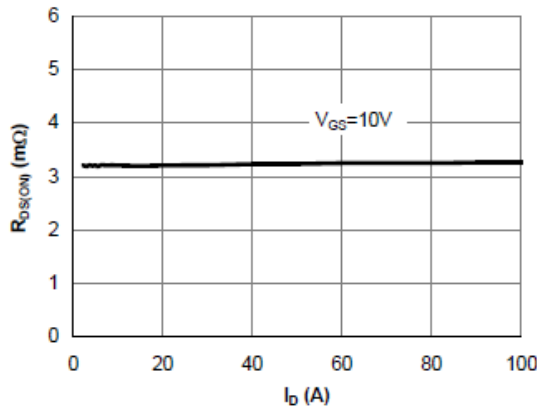

On-Resistance vs. Drain Current and Gate Voltage

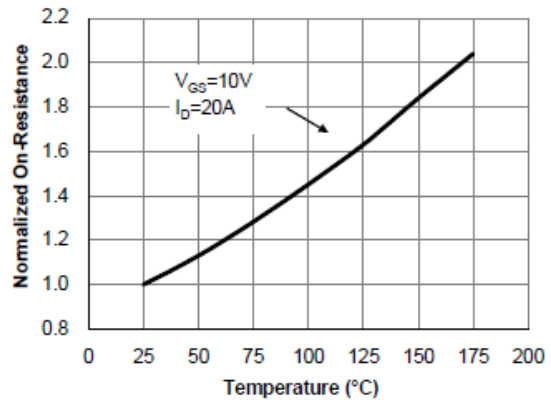

On-Resistance vs. Junction Temperature

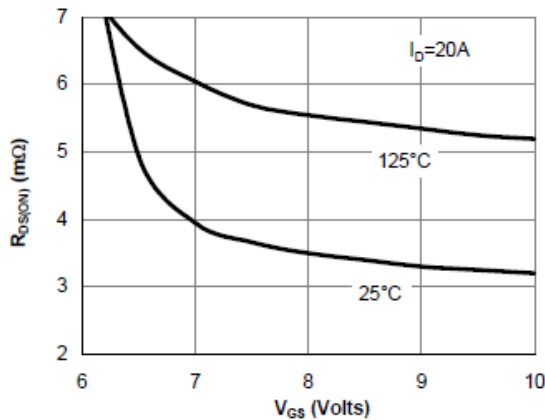

On-Resistance vs. Gate-Source Voltage

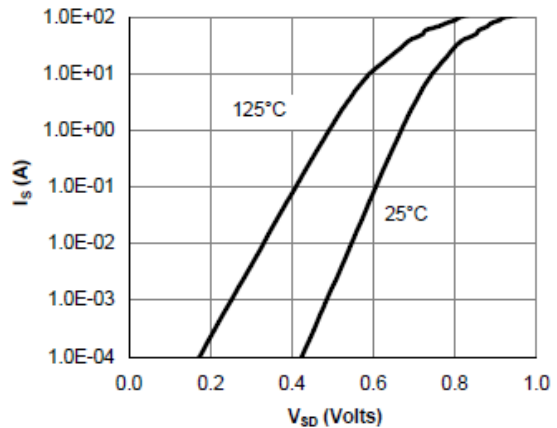

Body-Diode Characteristics



**Typical Characteristics**

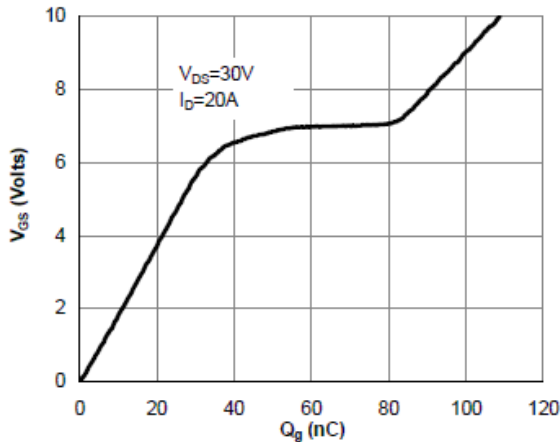

Gate-Charge Characteristics

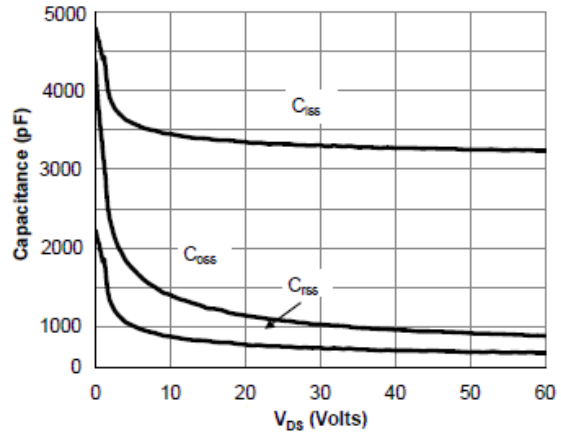

Capacitance Characteristics

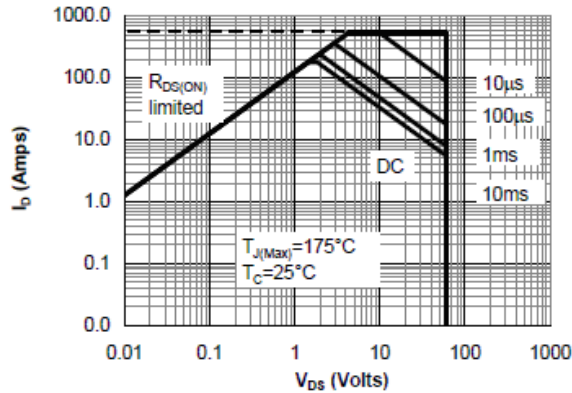

Maximum Forward Biased Safe Operating Area

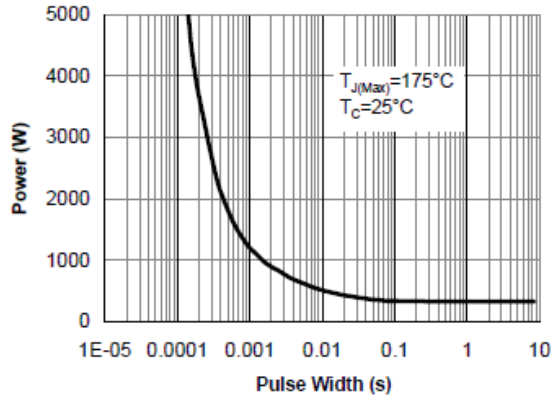

Single Pulse Power Rating Junction-to-Case

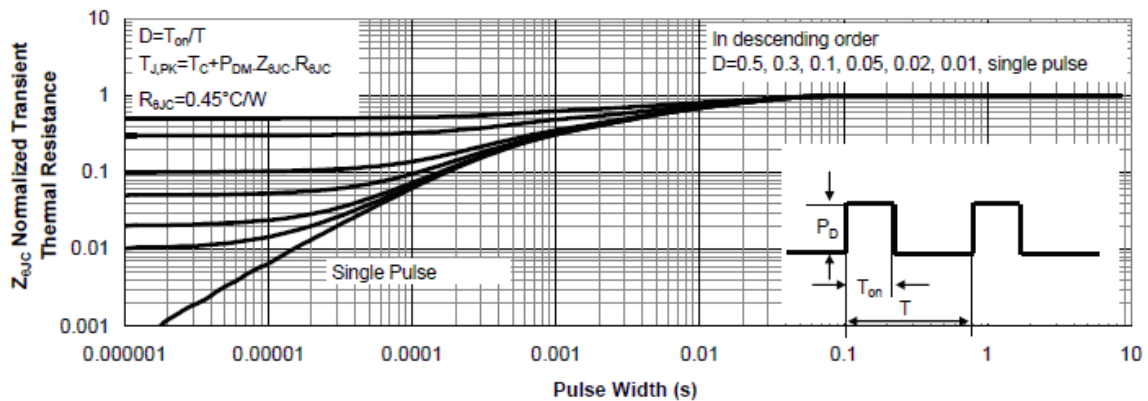

Normalized Maximum Transient Thermal Impedance



Typical Characteristics

Gate Charge Test Circuit & Waveform



Resistive Switching Test Circuit & Waveforms



Unclamped Inductive Switching Test Circuit & Waveforms

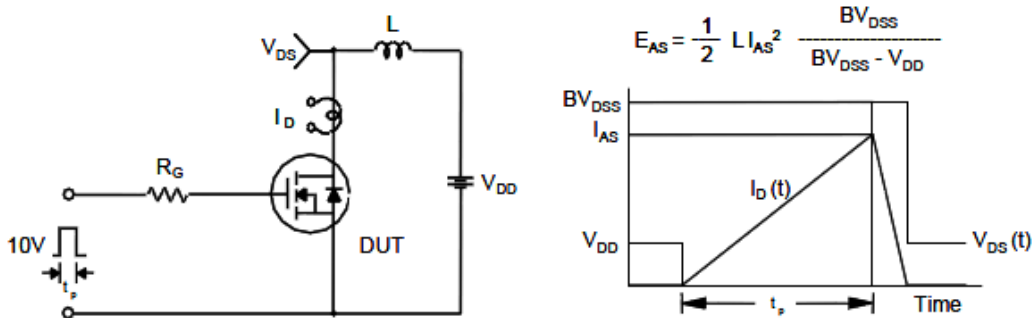



**Package Information ( TO-262 )**

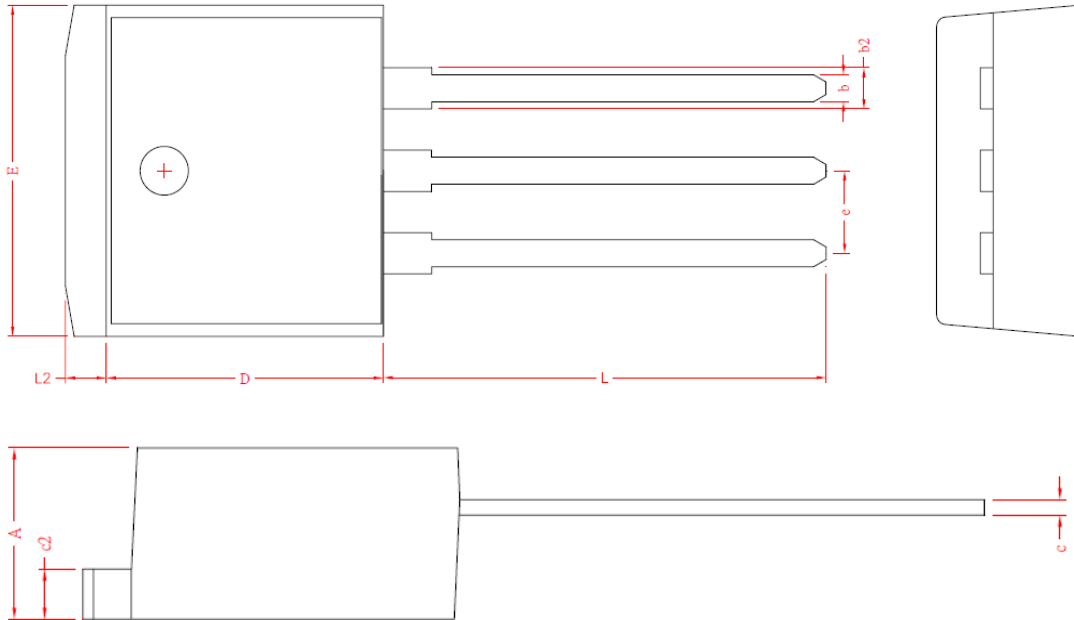

REF.	Millimeter		REF.	Millimeter	
	Min.	Max.		Min.	Max.
A	4.40	4.80	c2	1.25	1.45
b	0.76	1.0	b2	1.17	1.47
D	8.6	9.0	L	13.25	14.25
c	0.36	0.50	e	2.54 REF.	
E	9.80	10.4	L2	1.27 REF.	

©2010 Alfa-MOS Technology Corp.  
2F, No.80, Sec.1, Cheng Kung Rd., Nan Kang Dist., Taipei City 115, Taiwan (R.O.C.)  
Tel : 886 2) 2651 3928  
Fax : 886 2) 2786 8483  
©<http://www.alfa-mos.com>