



General Description

AFN6238S, N-Channel enhancement mode MOSFET, uses Advanced Trench Technology to provide excellent $R_{DS(ON)}$, low gate charge.

These devices are particularly suited for low voltage power management, such as smart phone and notebook computer and other battery powered circuits, and low in-line power loss are needed in commercial industrial surface mount applications.

Features

- 40V/20A, $R_{DS(ON)}=6.8m\Omega@V_{GS}=10V$
- 40V/15A, $R_{DS(ON)}=9.0m\Omega@V_{GS}=4.5V$
- Super high density cell design for extremely low $R_{DS(ON)}$
- Exceptional on-resistance and maximum DC current capability
- DFN 5X6-8L package design

Pin Description (DFN 5X6-8L)

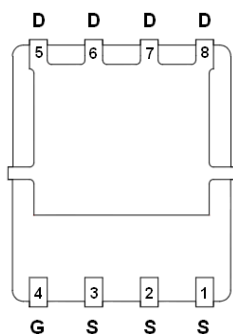

BOTTOM VIEW

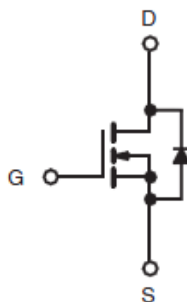

SYMBOL



TOP VIEW

Application

- Synchronous Rectification
- POL

Pin Define

Pin	Symbol	Description
1	S	Source
2	S	Source
3	S	Source
4	G	Gate
5	D	Drain
6	D	Drain
7	D	Drain
8	D	Drain

Ordering Information

Part Ordering No.	Part Marking	Package	Unit	Quantity
AFN6238SFN568RG	6238S	DFN 5X6-8L	Tape & Reel	2500 EA

※ 6238S : Parts Code

※ YYMMDD : Date Code

※ AFN6238SFN568RG : 13" Tape & Reel ; Pb- Free ; Halogen -Free



Absolute Maximum Ratings

(T_A=25°C Unless otherwise noted)

Parameter	Symbol	Value	Unit
Drain-Source Voltage	V _{DSS}	40	V
Gate –Source Voltage	V _{GSS}	±20	V
Continuous Drain Current(T _J =150°C)	I _D	T _A =25°C	22
		T _A =70°C	16
Pulsed Drain Current	I _{DM}	70	A
Continuous Source Current(Diode Conduction)	I _S	30	A
Power Dissipation	P _D	T _c =25°C	35
		T _c =70°C	16
Operating Junction Temperature	T _J	150	°C
Storage Temperature Range	T _{STG}	-55/150	°C
Thermal Resistance-Junction to Ambient	R _{θJA}	120	°C/W

Electrical Characteristics

(T_A=25°C Unless otherwise noted)

Parameter	Symbol	Conditions	Min.	Typ	Max.	Unit
Static						
Drain-Source Breakdown Voltage	V _{(BR)DSS}	V _{GS} =0V, I _D =250uA	40			V
Gate Threshold Voltage	V _{GS(th)}	V _{DS} =V _{GS} , I _D =250uA	1.0		2.5	
Gate Leakage Current	I _{GSS}	V _{DS} =0V, V _{GS} =±20V			±100	nA
Zero Gate Voltage Drain Current	I _{DSS}	V _{DS} =32V, V _{GS} =0V			1	uA
		V _{DS} =32V, V _{GS} =0V T _J =85°C			10	
On-State Drain Current	I _{D(on)}	V _{DS} ≥ 5V, V _{GS} =10V	50			A
Drain-Source On-Resistance	R _{DS(on)}	V _{GS} =10V, I _D =20A		4.5	6.8	mΩ
		V _{GS} =4.5V, I _D =15A		5.8	9.0	
Forward Transconductance	g _{FS}	V _{DS} =15V, I _D =20A		70		S
Diode Forward Voltage	V _{SD}	I _S =5A, V _{GS} =0V		0.8	1.3	V
Dynamic						
Total Gate Charge	Q _g	V _{DS} =20V, V _{GS} =4.5V I _D ≅20A		16	25	nC
Gate-Source Charge	Q _{gs}			4.2		
Gate-Drain Charge	Q _{gd}			5.6		
Input Capacitance	C _{iss}	V _{DS} =20V, V _{GS} =0V f=1MHz		1750		pF
Output Capacitance	C _{oss}			260		
Reverse Transfer Capacitance	C _{rss}			115		
Turn-On Time	t _{d(on)}	V _{DD} =20V, R _L =2.0Ω I _D ≅10A, V _{GEN} =10V R _G =1.0Ω		10	20	ns
	t _r			10	20	
Turn-Off Time	t _{d(off)}			20	40	
	t _f			10	20	



Typical Characteristics

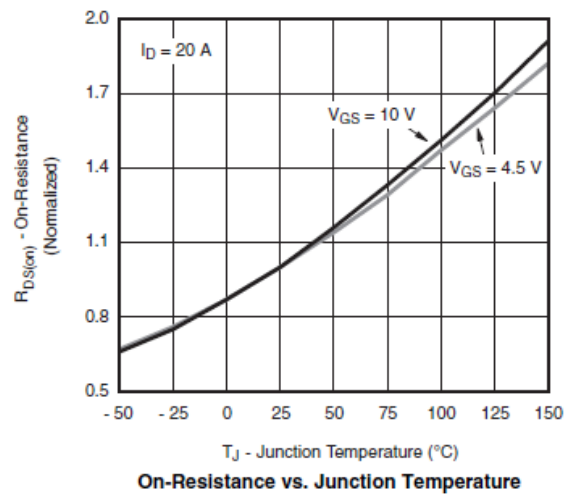
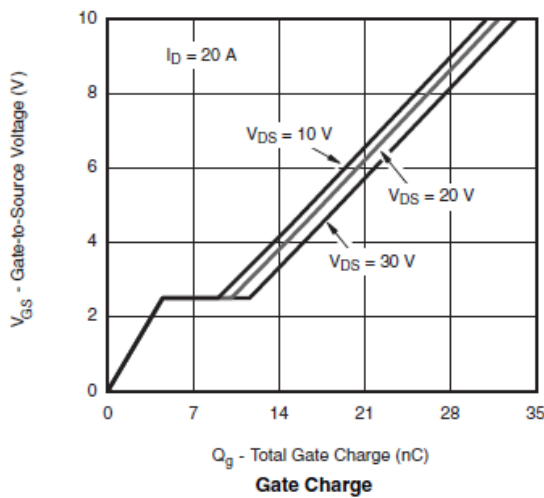
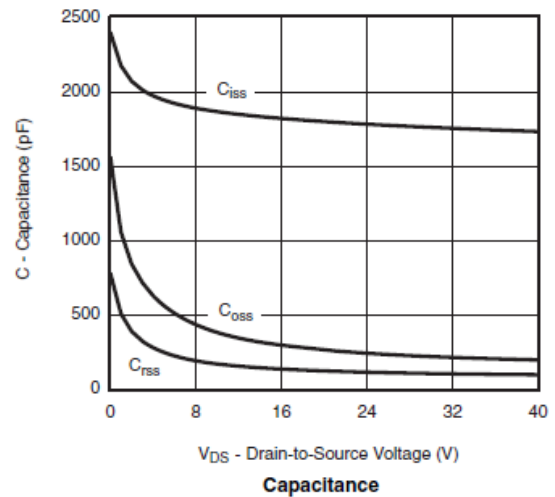
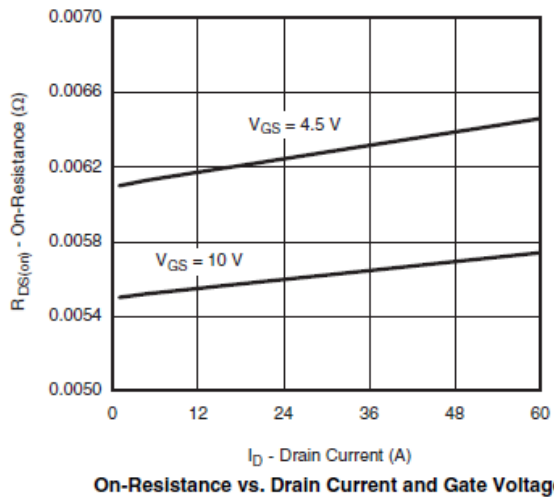
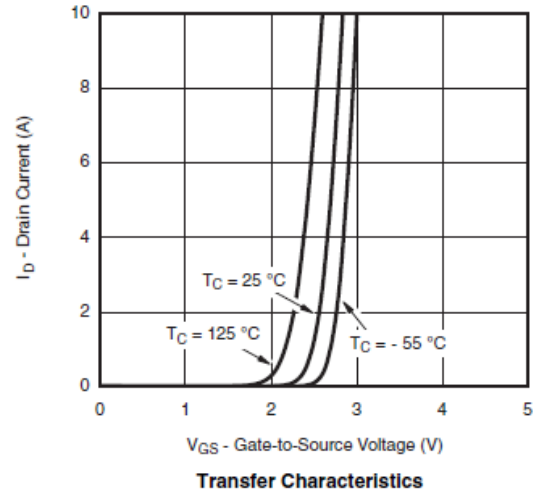
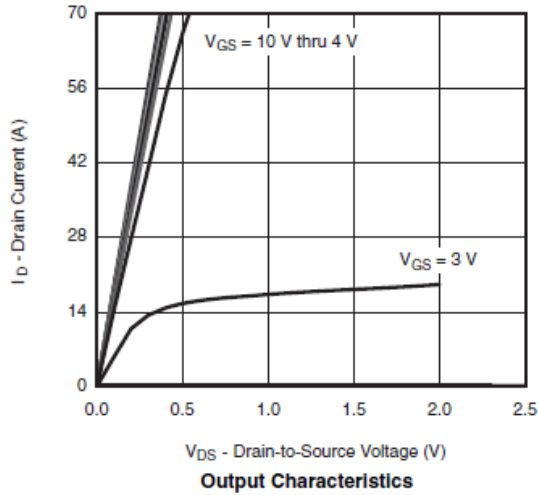



Typical Characteristics

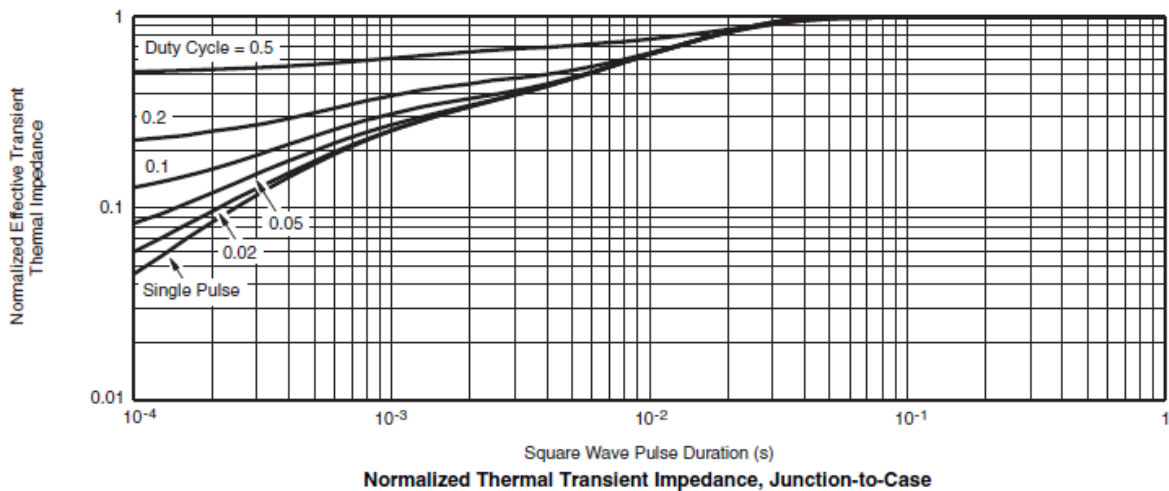
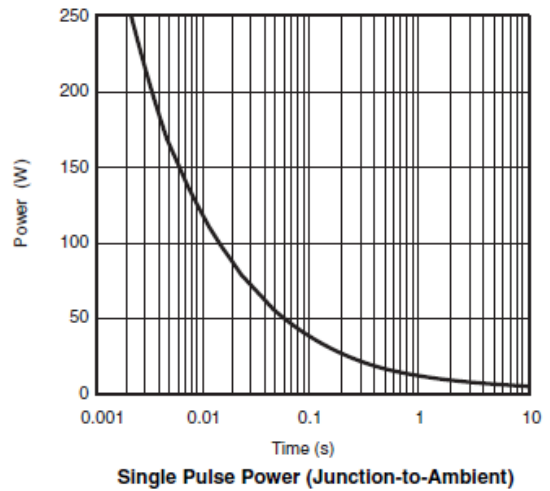
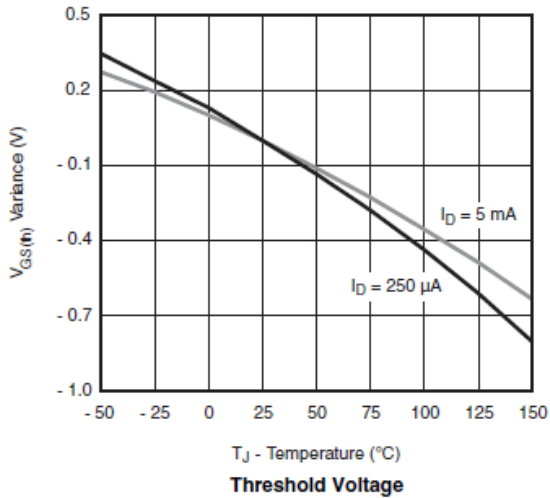
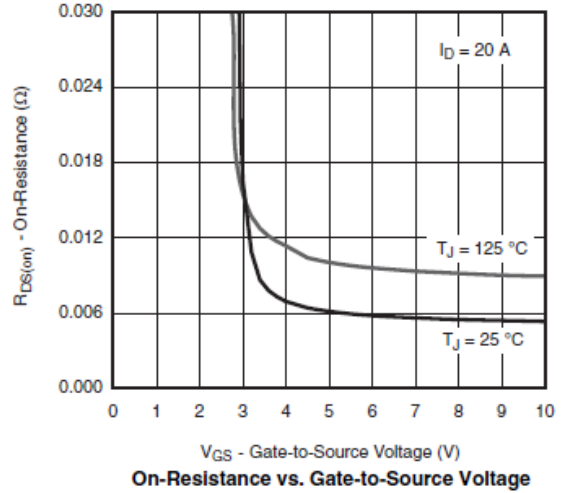
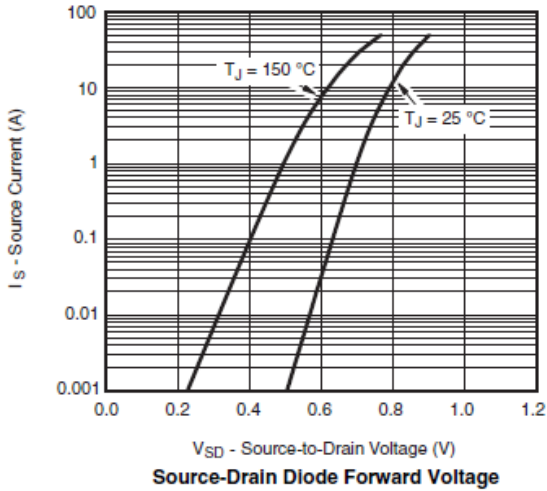



Typical Characteristics

Gate Charge Test Circuit & Waveform

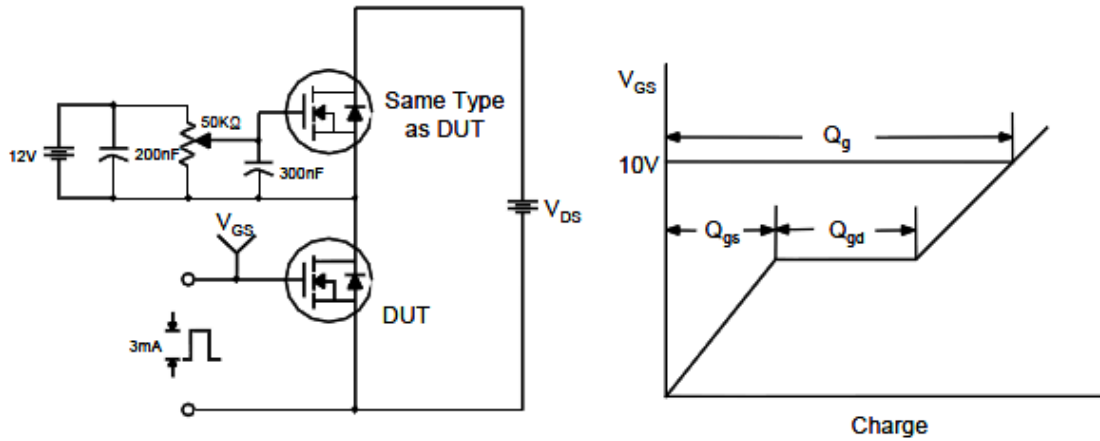

Resistive Switching Test Circuit & Waveforms

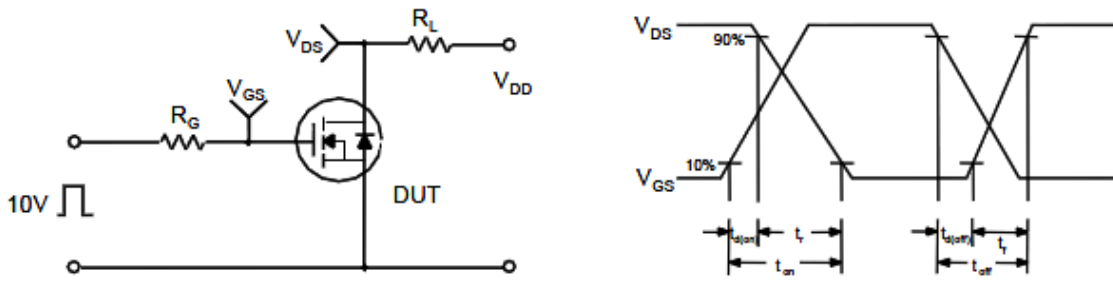

Unclamped Inductive Switching Test Circuit & Waveforms

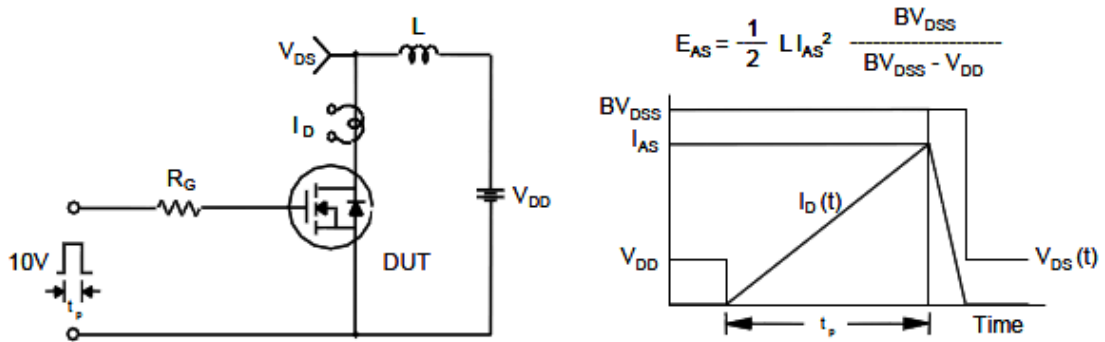



Package Information (DFN 5X6-8L)

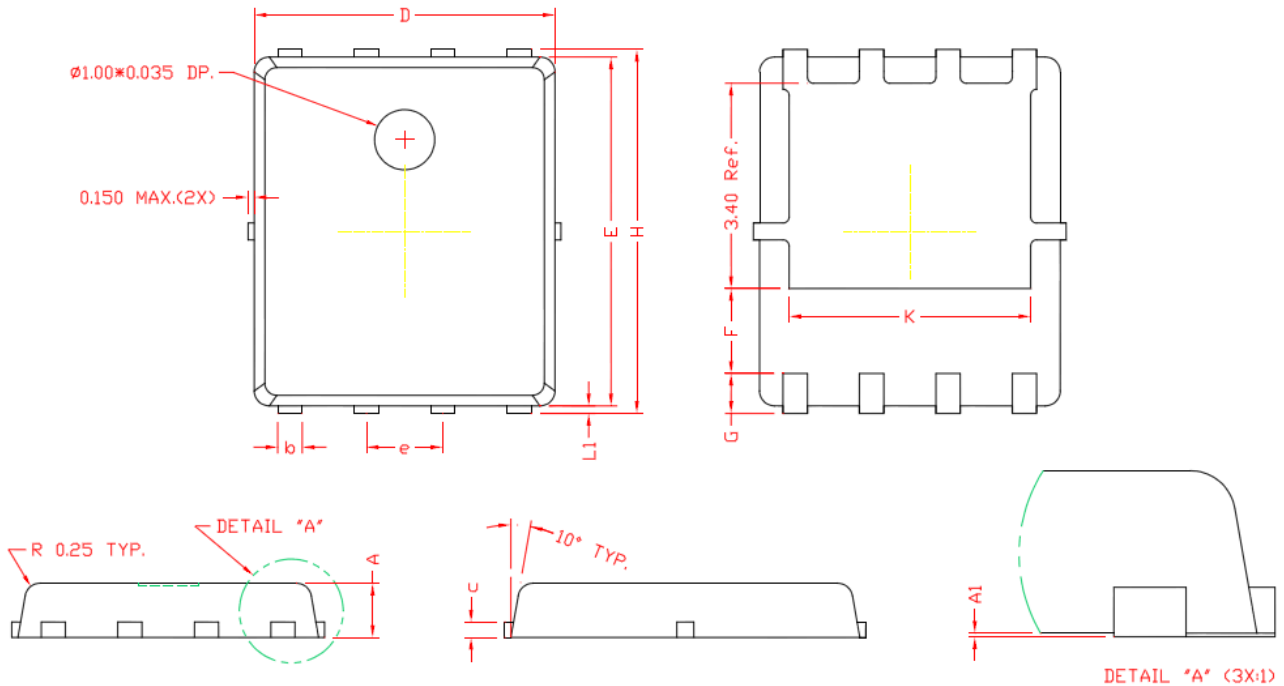

DIMENSIONS

REF.	Millimeters		REF.	Millimeters	
	Min.	Max.		Min.	Max.
A	0.80	1.00	E	5.70	5.90
A1	0.00	0.05	e	1.27 BSC.	
b	0.35	0.49	H	5.95	6.20
c	0.254 Ref.		L1	0.10	0.18
D	4.90	5.10	G	0.60 Ref.	
F	1.40 Ref.		K	4.00 Ref.	

©2010 Alfa-MOS Technology Corp.
 2F, No.80, Sec.1, Cheng Kung Rd., Nan Kang Dist., Taipei City 115, Taiwan (R.O.C.)
 Tel : 886 2) 2651 3928
 Fax : 886 2) 2786 8483
 ©http://www.alfa-mos.com