



### General Description

AFN6248S, N-Channel enhancement mode MOSFET, uses Advanced Trench Technology to provide excellent  $R_{DS(ON)}$ , low gate charge.

These devices are particularly suited for low voltage power management, and low in-line power loss are needed in commercial industrial surface mount applications.

### Features

- $I_D=18A, R_{DS(ON)}= 7.2m\Omega@V_{GS}=10V$
- $I_D=14A, R_{DS(ON)}= 8.8m\Omega@V_{GS}=4.5V$
- Super high density cell design for extremely low  $R_{DS(ON)}$
- DFN5X6-8L package design

### Pin Description ( DFN5X6-8L )

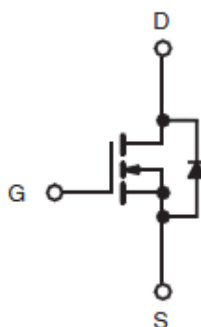
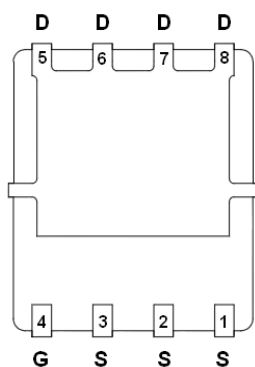

### Application

- Synchronous Rectifier
- Power Supplies
- LED TV

### Pin Define

Pin	Symbol	Description
4	G	Gate
1~3	S	Source
5~8	D	Drain

### Ordering Information

Part Ordering No.	Part Marking	Package	Unit	Quantity
AFN6248SFN568RG	6248S	DFN5X6-8L	Tape & Reel	2500 EA

- ※ 6248S : Parts Code
- ※ YYMMDD : Date Code
- ※ AFN6248SFN568RG : 13" Tape & Reel ; Pb- Free ; Halogen- Free



**Absolute Maximum Ratings**

(T<sub>A</sub>=25°C Unless otherwise noted)

Parameter	Symbol	Value	Unit
Drain-Source Voltage	V <sub>DSS</sub>	60	V
Gate –Source Voltage	V <sub>GSS</sub>	±20	V
Continuous Drain Current(T <sub>J</sub> =150°C)	I <sub>DSM</sub>	T <sub>A</sub> =25°C	18
		T <sub>A</sub> =70°C	14
Pulsed Drain Current	I <sub>DM</sub>	40	A
Continuous Source Current(Diode Conduction)	I <sub>S</sub>	4.3	
Single Pulse Avalanche Current	I <sub>AS</sub>	50	
Power Dissipation	P <sub>DSM</sub>	T <sub>A</sub> =25°C	7.4
		T <sub>A</sub> =75°C	4.7
Operating Junction Temperature	T <sub>J</sub>	150	°C
Storage Temperature Range	T <sub>STG</sub>	-55/150	°C
Thermal Resistance-Junction to Ambient	R <sub>θJA</sub>	t ≤ 10 s	15
		Steady-State	45

**Electrical Characteristics**

(T<sub>A</sub>=25°C Unless otherwise noted)

Parameter	Symbol	Conditions	Min.	Typ	Max.	Unit
<b>Static</b>						
Drain-Source Breakdown Voltage	V <sub>(BR)DSS</sub>	V <sub>GS</sub> =0V, I <sub>D</sub> =250uA	60			V
Gate Threshold Voltage	V <sub>GS(th)</sub>	V <sub>DS</sub> =V <sub>GS</sub> , I <sub>D</sub> =250uA	2.0		4.0	
Gate Leakage Current	I <sub>GSS</sub>	V <sub>DS</sub> =0V, V <sub>GS</sub> =±20V			±100	nA
Zero Gate Voltage Drain Current	I <sub>DSS</sub>	V <sub>DS</sub> =48V, V <sub>GS</sub> =0V			1	uA
		V <sub>DS</sub> =48V, V <sub>GS</sub> =0V T <sub>J</sub> =85°C			30	
On-State Drain Current	I <sub>D(on)</sub>	V <sub>DS</sub> ≥ 10V, V <sub>GS</sub> =10V	80			A
Drain-Source On-Resistance	R <sub>DS(on)</sub>	V <sub>GS</sub> =10V, I <sub>D</sub> =18A		6.3	7.2	mΩ
		V <sub>GS</sub> =6V, I <sub>D</sub> =14A		7.7	8.8	
Forward Transconductance	g <sub>FS</sub>	V <sub>DS</sub> =15V, I <sub>D</sub> =15A		38		S
Diode Forward Voltage	V <sub>SD</sub>	I <sub>S</sub> =10A, V <sub>GS</sub> =0V		0.8	1.3	V
<b>Dynamic</b>						
Total Gate Charge	Q <sub>g</sub>	V <sub>DS</sub> =30V, V <sub>GS</sub> =10V I <sub>D</sub> ≅18A		65	90	nC
Gate-Source Charge	Q <sub>gs</sub>			10		
Gate-Drain Charge	Q <sub>gd</sub>			15		
Input Capacitance	C <sub>iss</sub>	V <sub>DS</sub> =30V, V <sub>GS</sub> =0V f=1MHz		3000		pF
Output Capacitance	C <sub>oss</sub>			600		
Reverse Transfer Capacitance	C <sub>rss</sub>			300		
Turn-On Time	t <sub>d(on)</sub>	V <sub>DD</sub> =30V, R <sub>L</sub> =30Ω I <sub>D</sub> ≅1A, V <sub>GEN</sub> =10V R <sub>G</sub> =6Ω		50	30	ns
	t <sub>r</sub>			15	25	
Turn-Off Time	t <sub>d(off)</sub>			60	100	
	t <sub>f</sub>		30	45		



## Typical Characteristics

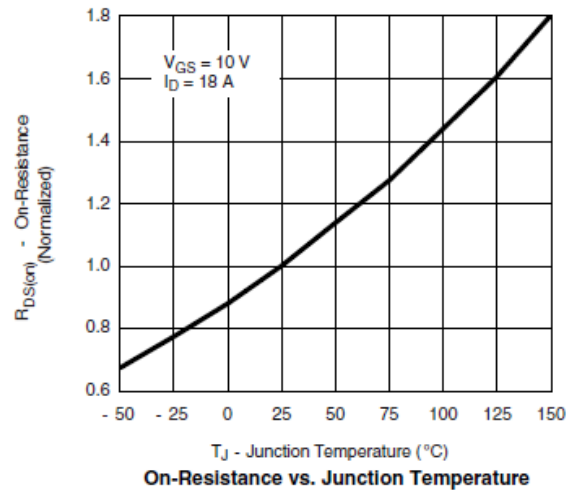
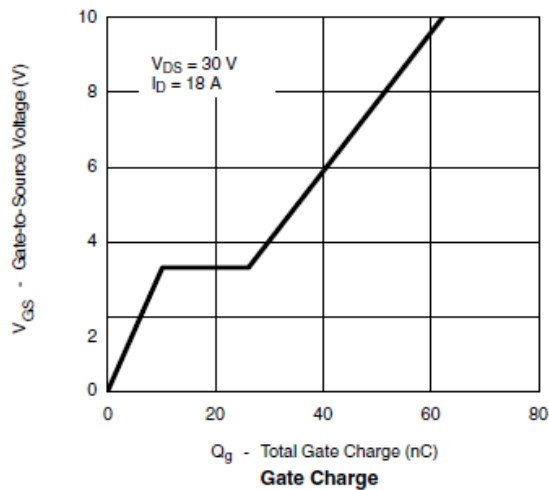
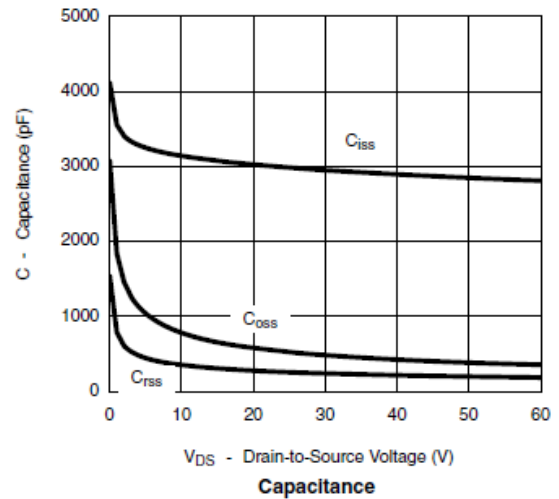
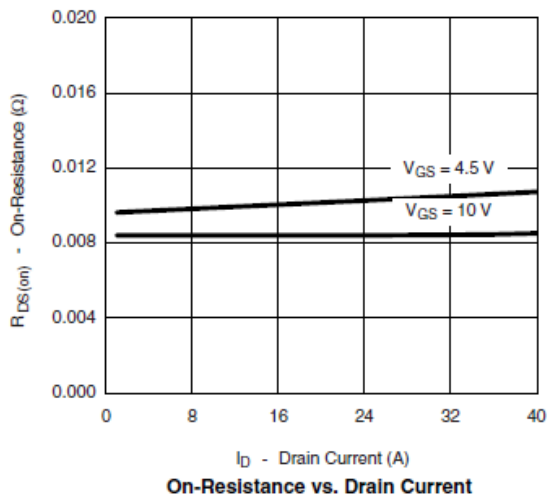
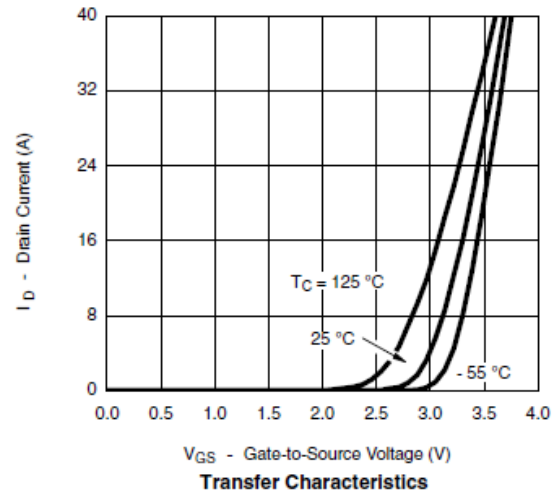
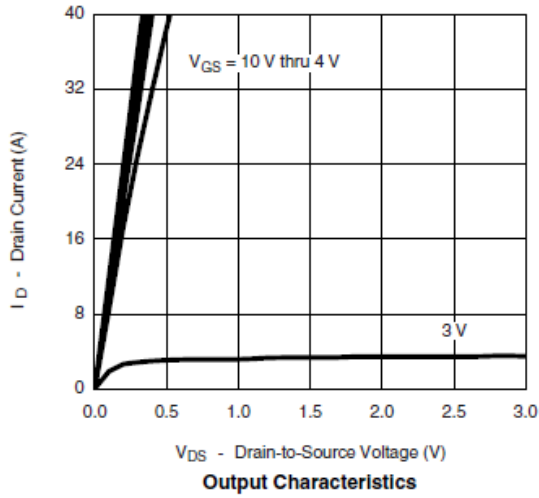



## Typical Characteristics

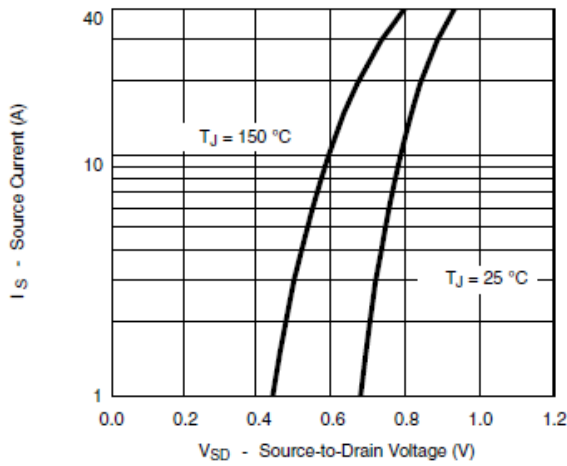

Source-Drain Diode Forward Voltage

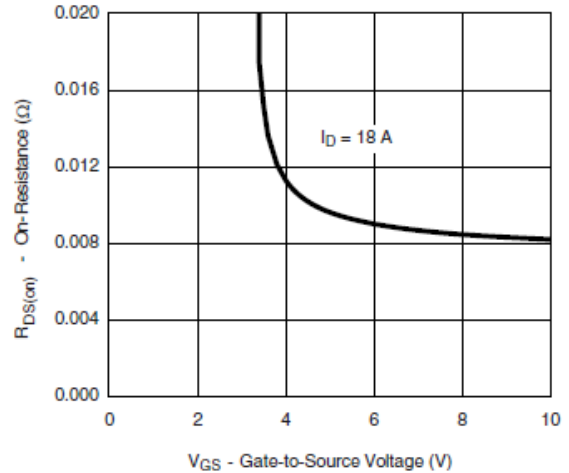

On-Resistance vs. Gate-to-Source Voltage

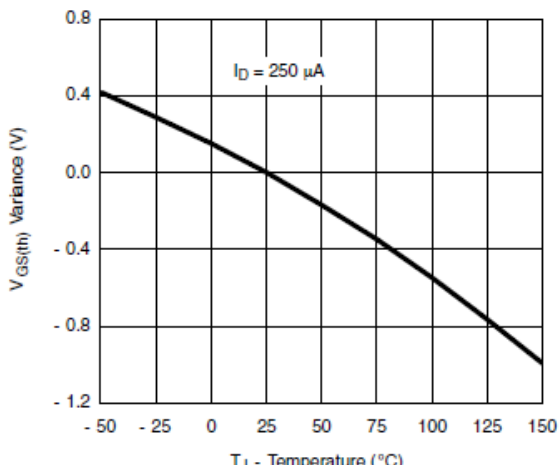

Threshold Voltage

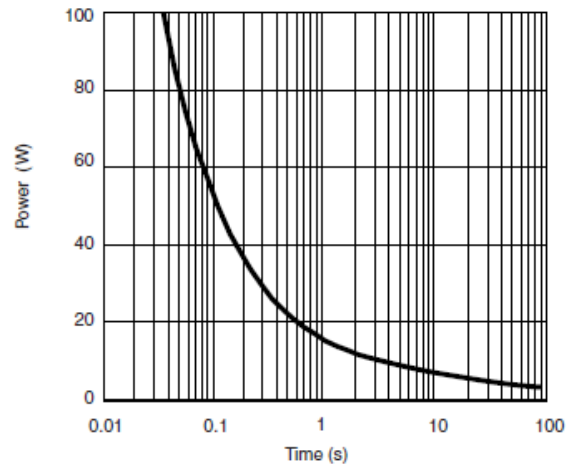

Single Pulse Power, Junction-to-Ambient

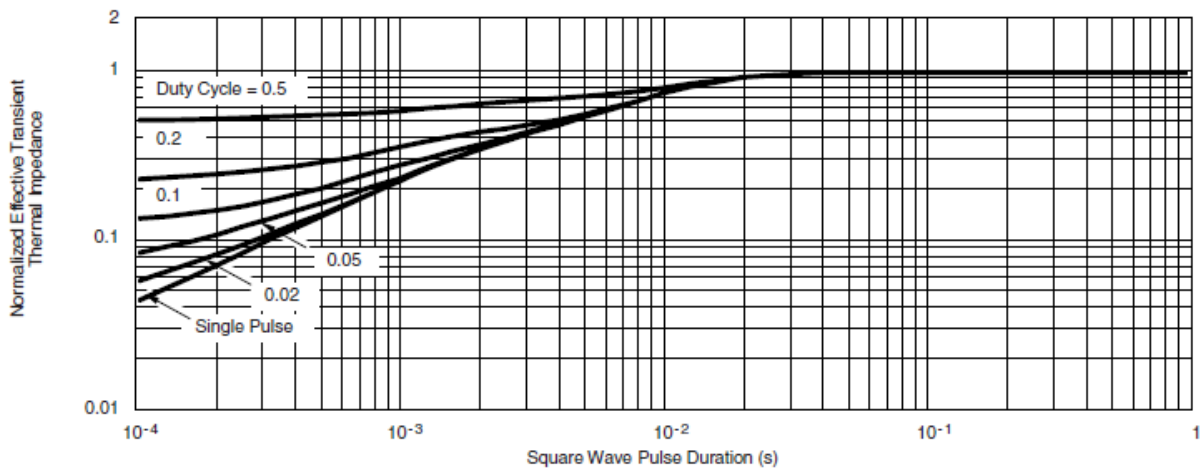

Normalized Thermal Transient Impedance, Junction-to-Case



**Typical Characteristics**

Gate Charge Test Circuit & Waveform



Resistive Switching Test Circuit & Waveforms



Unclamped Inductive Switching Test Circuit & Waveforms





**Package Information ( DFN5X6-8L )**

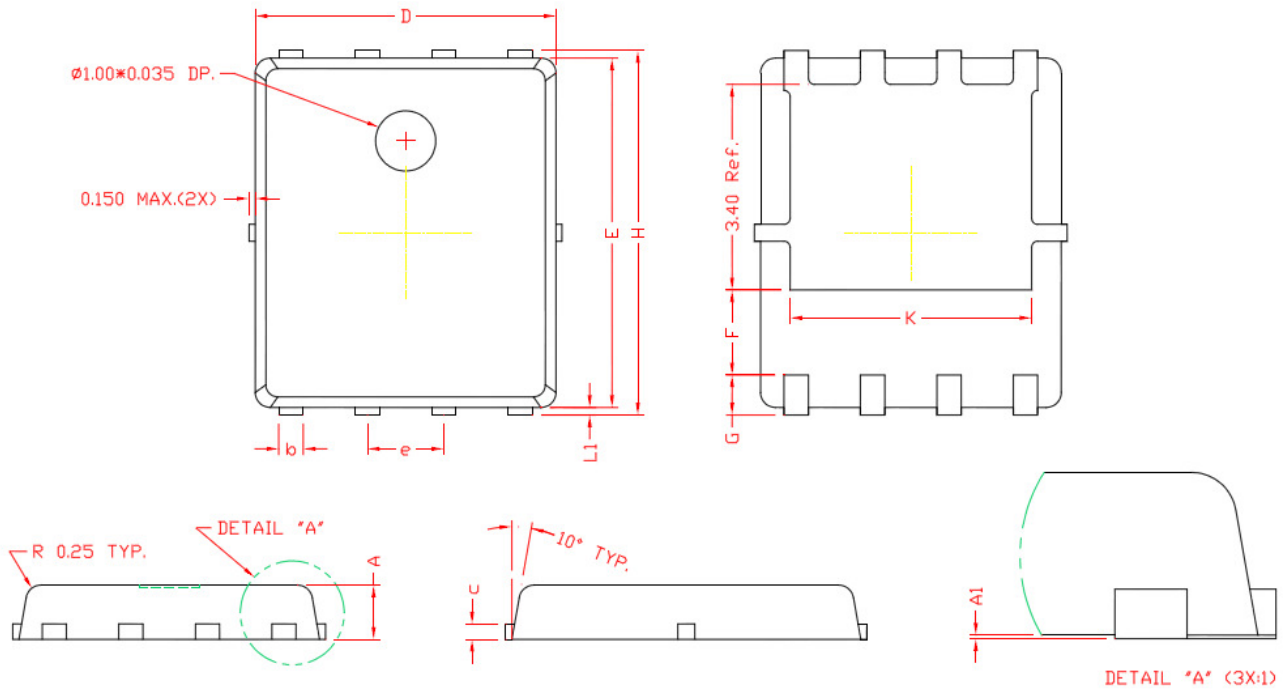

**DIMENSIONS**

REF.	Millimeters		REF.	Millimeters	
	Min.	Max.		Min.	Max.
A	0.80	1.00	E	5.70	5.90
A1	0.00	0.05	e	1.27 BSC.	
b	0.35	0.49	H	5.95	6.20
c	0.254 Ref.		L1	0.10	0.18
D	4.90	5.10	G	0.60 Ref.	
F	1.40 Ref.		K	4.00 Ref.	

©2010 Alfa-MOS Technology Corp.  
 2F, No.80, Sec.1, Cheng Kung Rd., Nan Kang Dist., Taipei City 115, Taiwan (R.O.C.)  
 Tel : 886 2) 2651 3928  
 Fax : 886 2) 2786 8483  
 ©<http://www.alfa-mos.com>