



General Description

AFN6252S, N-Channel enhancement mode MOSFET, uses Advanced Trench Technology to provide excellent $R_{DS(ON)}$, low gate charge.

These devices are particularly suited for low voltage power management, and low in-line power loss are needed in commercial industrial surface mount applications.

Features

- $I_D=5.9A, R_{DS(ON)}= 64m\Omega@V_{GS}=10V$
- $I_D=4.8A, R_{DS(ON)}= 70m\Omega@V_{GS}=6V$
- Super high density cell design for extremely low $R_{DS(ON)}$
- DFN5X6-8L package design

Pin Description (DFN5X6-8L)

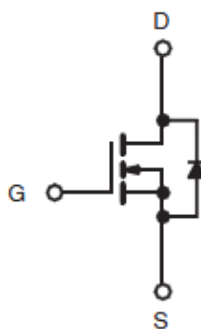
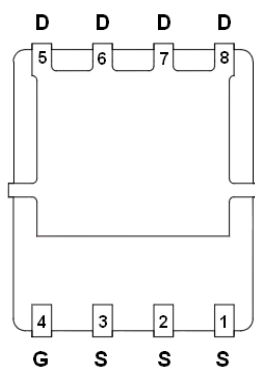

Application

- Synchronous Rectifier
- Power Supplies
- LED TV

Pin Define

Pin	Symbol	Description
1~3	S	Source
4	G	Gate
5~8	D	Drain

Ordering Information

Part Ordering No.	Part Marking	Package	Unit	Quantity
AFN6252SFN568RG	6252S	DFN5X6-8L	Tape & Reel	2500 EA

※ 6252S : Parts Code

※ YYMMDD : Date Code

※ AFN6252SFN568RG : 13" Tape & Reel ; Pb- Free ; Halogen- Free



Absolute Maximum Ratings

(T_A=25°C Unless otherwise noted)

Parameter	Symbol	Value	Unit
Drain-Source Voltage	V _{DSS}	150	V
Gate –Source Voltage	V _{GSS}	±20	V
Continuous Drain Current(T _J =150°C)	I _{DSM}	T _C =25°C	18
		T _C =70°C	12
		T _A =25°C	5.9
		T _A =70°C	4.8
Pulsed Drain Current	I _{DM}	30	A
Continuous Source Current(Diode Conduction)	I _S	30	
Single Pulse Avalanche Current	L = 0.1 mH I _{AS}	15	
Power Dissipation	P _{DSM}	T _A =25°C	2
		T _A =75°C	1.25
Operating Junction Temperature	T _J	150	°C
Storage Temperature Range	T _{STG}	-55/150	°C
Thermal Resistance-Junction to Ambient	R _{θJA}	t ≤ 10 s	15
		Steady-State	45

Electrical Characteristics

(T_A=25°C Unless otherwise noted)

Parameter	Symbol	Conditions	Min.	Typ	Max.	Unit
Static						
Drain-Source Breakdown Voltage	V _{(BR)DSS}	V _{GS} =0V, I _D =250uA	150			V
Gate Threshold Voltage	V _{GS(th)}	V _{DS} =V _{GS} , I _D =250uA	2	3	4	
Gate Leakage Current	I _{GSS}	V _{DS} =0V, V _{GS} =±20V			±100	nA
Zero Gate Voltage Drain Current	I _{DSS}	V _{DS} =120V, V _{GS} =0V			1	uA
		V _{DS} =120V, V _{GS} =0V T _J =85°C			5	
On-State Drain Current	I _{D(on)}	V _{DS} ≥ 5V, V _{GS} =10V	25			A
Drain-Source On-Resistance	R _{DS(on)}	V _{GS} =10V, I _D =5.9A		52	64	mΩ
		V _{GS} =6V, I _D =4.8A		55	70	
Forward Transconductance	g _{FS}	V _{DS} =15V, I _D =25A		40		S
Diode Forward Voltage	V _{SD}	I _S =2.5A, V _{GS} =0V		0.8	1.2	V
Dynamic						
Total Gate Charge	Q _g	V _{DS} =75V, V _{GS} =10V I _D =5.9A		30	50	nC
Gate-Source Charge	Q _{gs}			10		
Gate-Drain Charge	Q _{gd}			12		
Input Capacitance	C _{iss}	V _{DS} =25V, V _{GS} =0V f=1MHz		1685		pF
Output Capacitance	C _{oss}			215		
Reverse Transfer Capacitance	C _{rss}			100		
Turn-On Time	t _{d(on)}	V _{DD} =50V, R _L =3Ω I _D ≅4.8, V _{GEN} =10V R _G =2.5Ω		15	30	ns
	t _r			70	135	
Turn-Off Time	t _{d(off)}			25	50	
	t _f			60	100	



Typical Characteristics

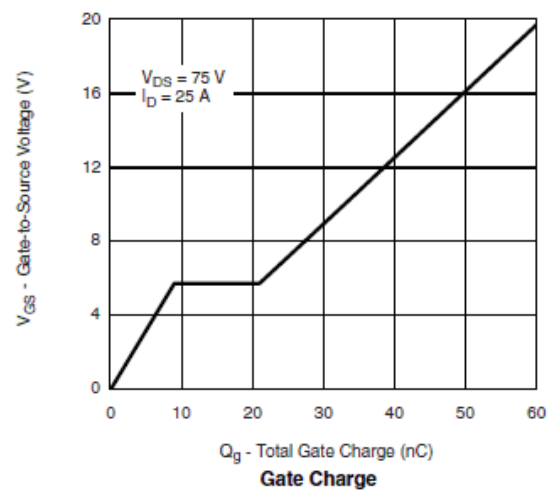
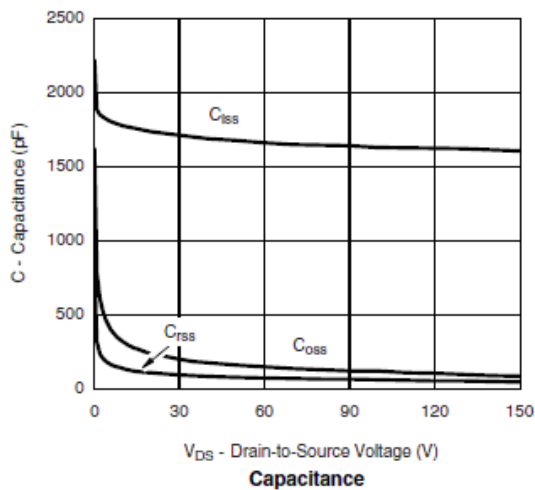
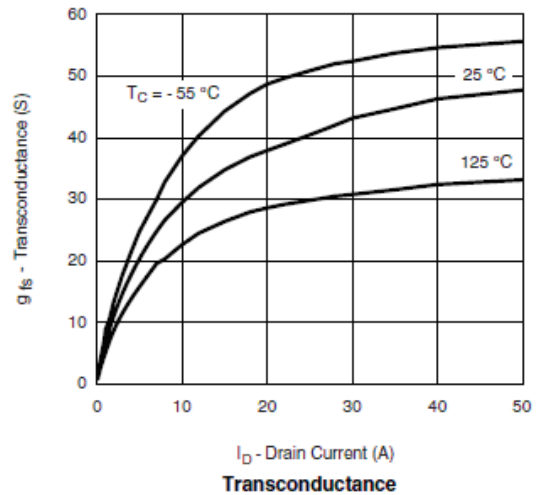
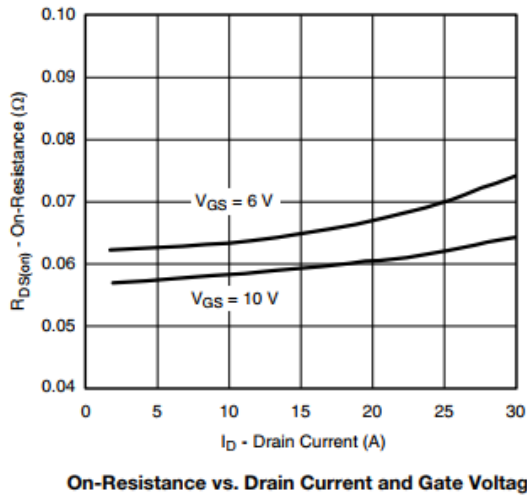
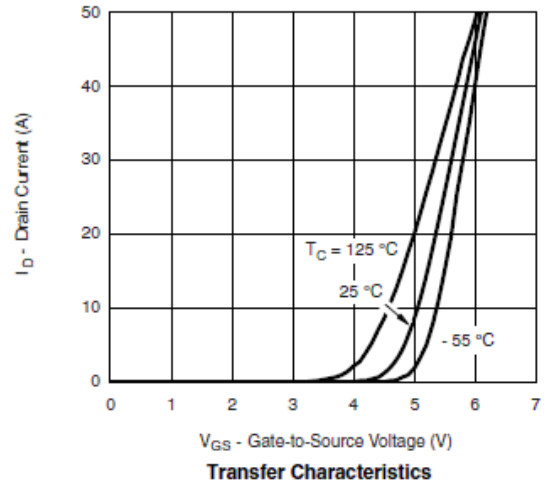
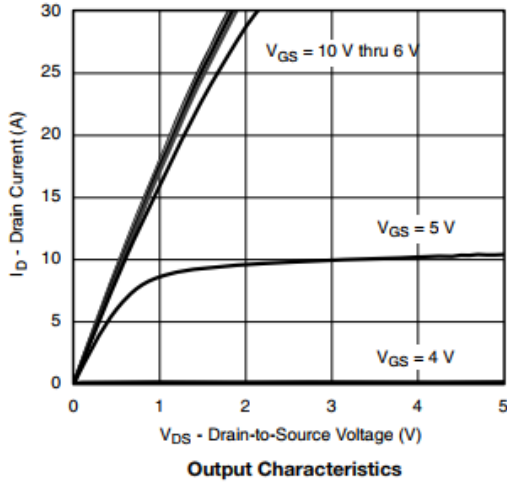



Typical Characteristics

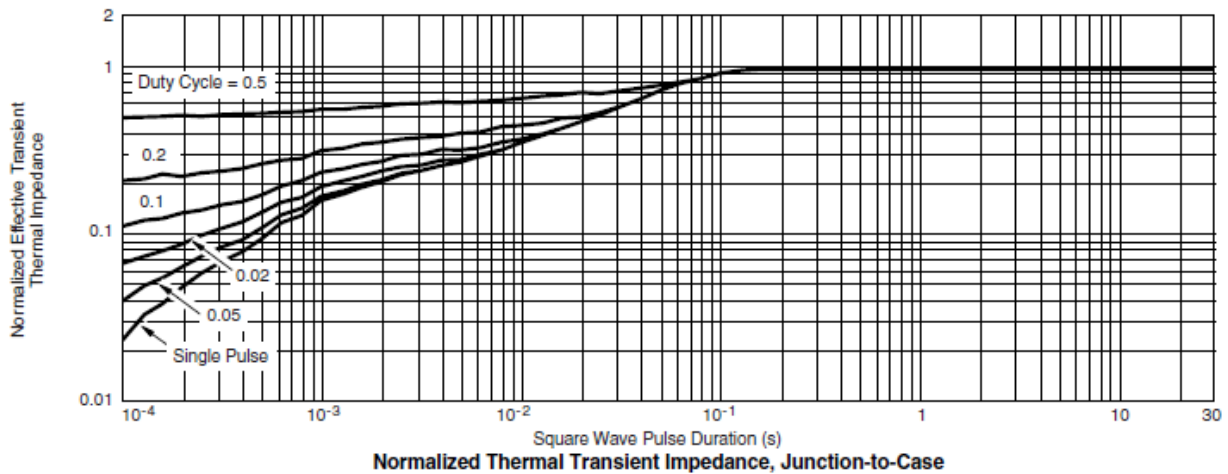
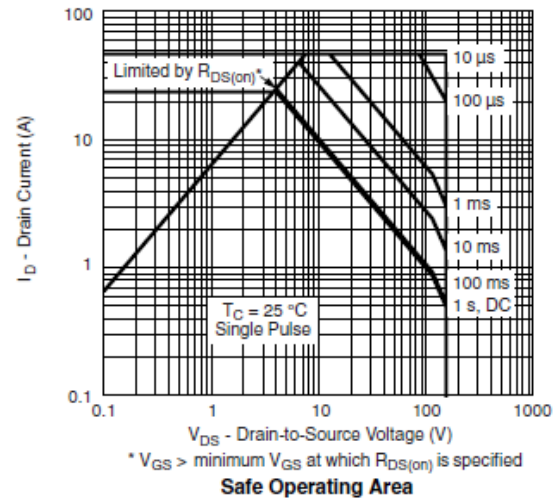
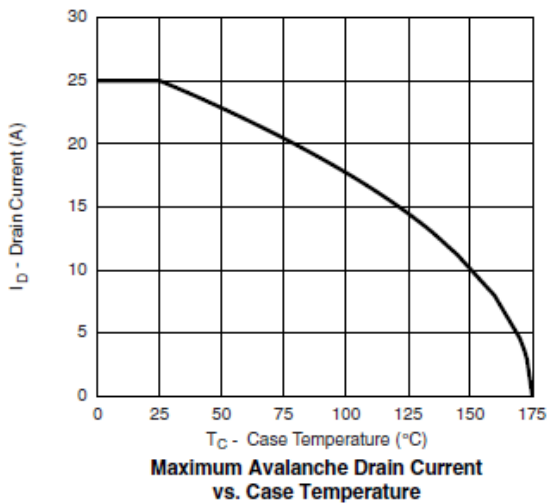
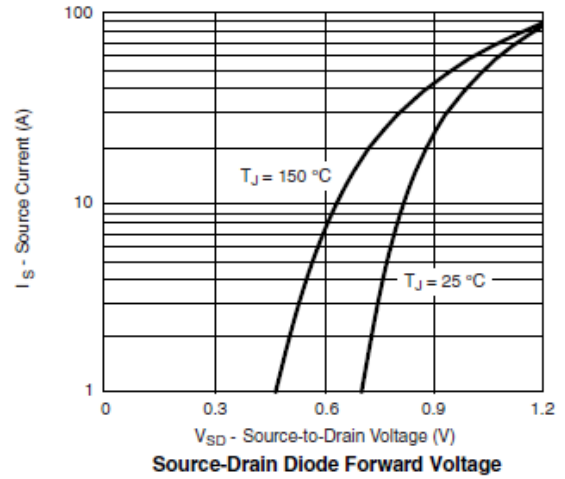
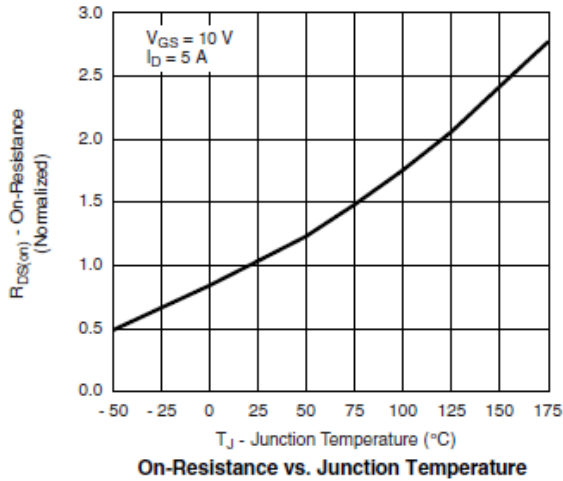



Typical Characteristics

Gate Charge Test Circuit & Waveform

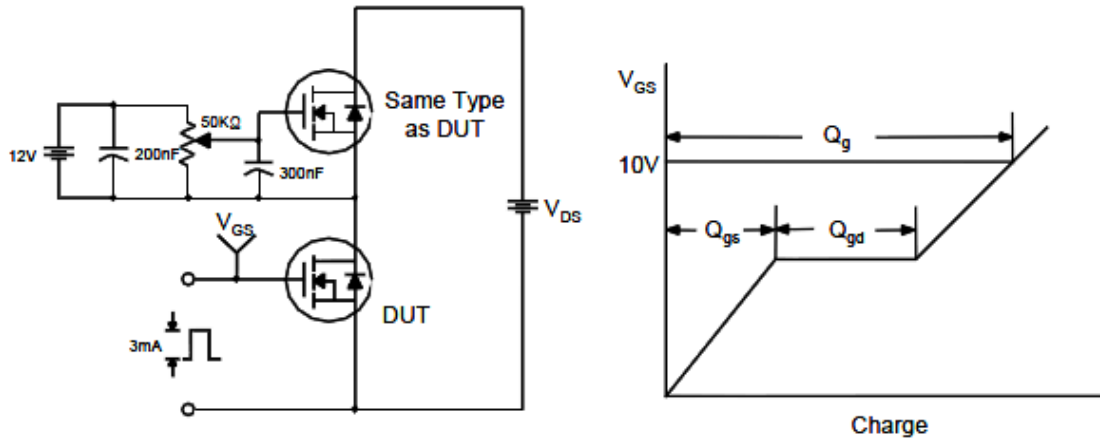

Resistive Switching Test Circuit & Waveforms

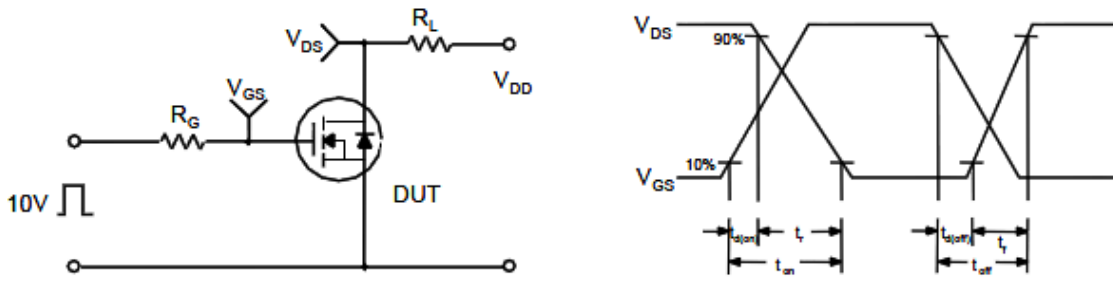

Unclamped Inductive Switching Test Circuit & Waveforms

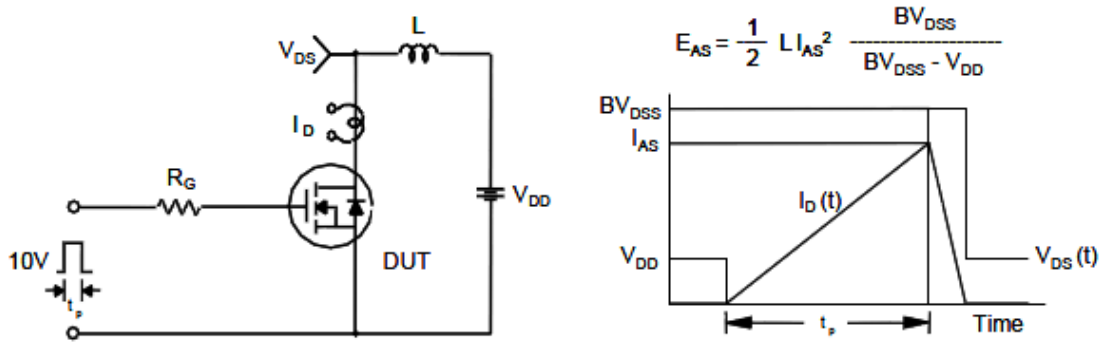



Package Information (DFN5X6-8L)

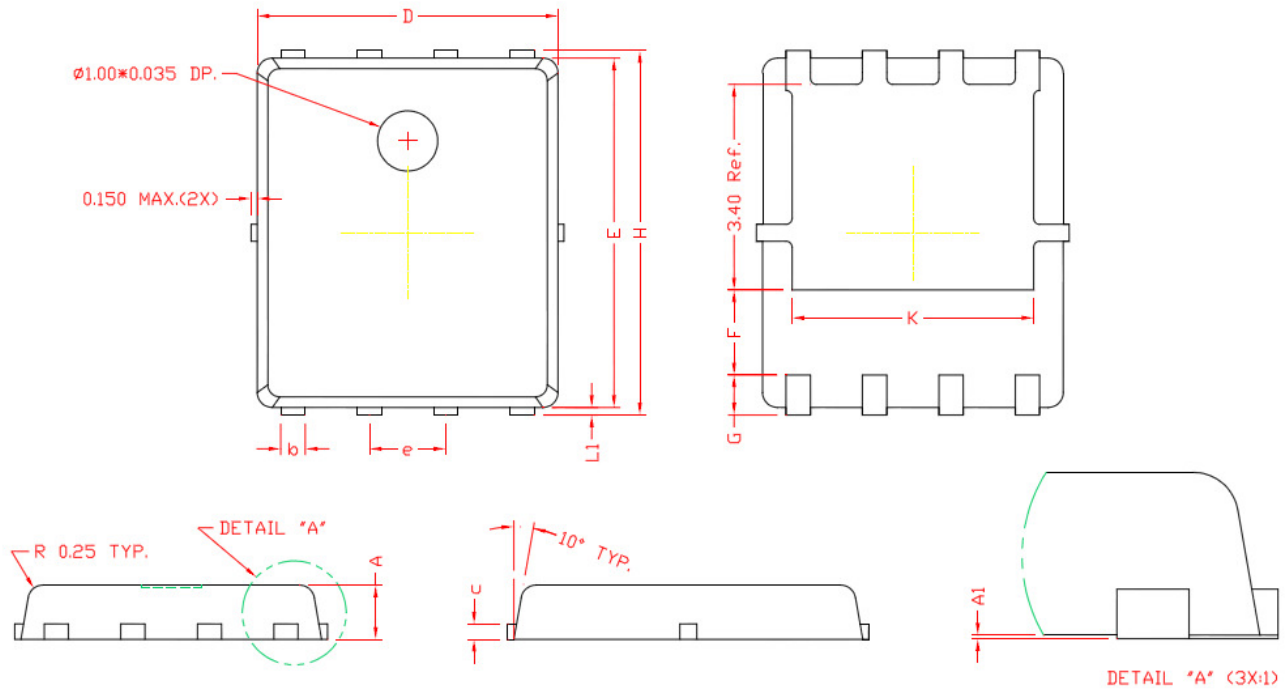

DIMENSIONS

REF.	Millimeters		REF.	Millimeters	
	Min.	Max.		Min.	Max.
A	0.80	1.00	E	5.70	5.90
A1	0.00	0.05	e	1.27 BSC.	
b	0.35	0.49	H	5.95	6.20
c	0.254 Ref.		L1	0.10	0.18
D	4.90	5.10	G	0.60 Ref.	
F	1.40 Ref.		K	4.00 Ref.	

©2010 Alfa-MOS Technology Corp.
 2F, No.80, Sec.1, Cheng Kung Rd., Nan Kang Dist., Taipei City 115, Taiwan (R.O.C.)
 Tel : 886 2) 2651 3928
 Fax : 886 2) 2786 8483
 ©http://www.alfa-mos.com