



General Description

AFN6688S, N-Channel enhancement mode MOSFET, uses Advanced Trench Technology to provide excellent $R_{DS(ON)}$, low gate charge.

These devices are particularly suited for low voltage power management, and low in-line power loss are needed in commercial industrial surface mount applications.

Features

- $I_D=20A, R_{DS(ON)}=3.6m\Omega@V_{GS}=10V$
- $I_D=10A, R_{DS(ON)}=5.5m\Omega@V_{GS}=4.5V$
- Super high density cell design for extremely low $R_{DS(ON)}$
- DFN5X6-8L package design

Pin Description (DFN5X6-8L)

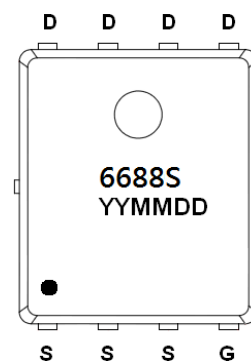
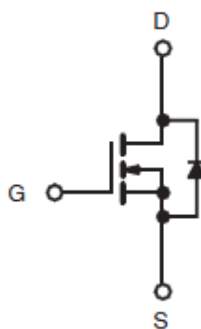
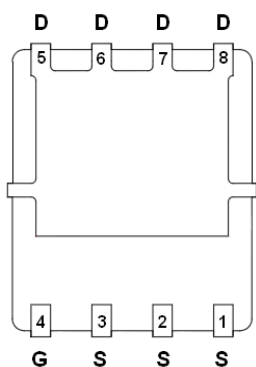

Application

- Networking / Telecom / Server
- LED Lighting Applications
- Quick Charger Applications
- DC-DC Primary Side Switch

Pin Define

Pin	Symbol	Description
1~3	S	Source
4	G	Gate
5~8	D	Drain

Ordering Information

Part Ordering No.	Part Marking	Package	Unit	Quantity
AFN6688SFN568RG	6688S	DFN5X6-8L	Tape & Reel	2500 EA

- ※ 6688S : Parts Code
- ※ YYMMDD : Date Code
- ※ AFN6688SFN568RG : 13" Tape & Reel ; Pb- Free ; Halogen- Free



Absolute Maximum Ratings

(T_A=25°C Unless otherwise noted)

Parameter	Symbol	Typical	Unit
Drain-Source Voltage	V _{DSS}	60	V
Gate –Source Voltage	V _{GSS}	±25	V
Continuous Drain Current(T _J =150°C)	I _{DSM}	T _C =25°C	60
		T _C =70°C	60
Pulsed Drain Current (t=100us)	I _{DM}	T _A =25°C	29
		T _A =70°C	23
Continuous Source Current(Diode Conduction)	I _S	60	A
Single Pulse Avalanche Current	I _{AS}	T _C =25°C	4.9
		T _A =25°C	30
Power Dissipation	P _D	L=0.1mH	45
		T _C =25°C	80
Operating Junction Temperature	T _J	T _C =75°C	50
		T _A =25°C	5.4
Storage Temperature Range	T _{STG}	150	°C
Thermal Resistance-Junction to Ambient	R _{θJA}	-55/150	°C
Maximum Junction-to-Case (Drain)	R _{θJA}	t ≤ 10 s	23
		Steady-State	1.5

Electrical Characteristics

(T_A=25°C Unless otherwise noted)

Parameter	Symbol	Conditions	Min.	Typ	Max.	Unit
Static						
Drain-Source Breakdown Voltage	V _{(BR)DSS}	V _{GS} =0V, I _D =250uA	60			V
Gate Threshold Voltage	V _{GS(th)}	V _{DS} =V _{GS} , I _D =250uA	1.0		2.5	
Gate Leakage Current	I _{GSS}	V _{DS} =0V, V _{GS} =±25V			±100	nA
Zero Gate Voltage Drain Current	I _{DSS}	V _{DS} =48V, V _{GS} =0V			1	uA
		V _{DS} =48V, V _{GS} =0V T _J =85°C			10	
On-State Drain Current	I _{D(on)}	V _{DS} ≥ 5V, V _{GS} =10V	30			A
Drain-Source On-Resistance	R _{DS(on)}	V _{GS} =10V, I _D =20A		2.9	3.6	mΩ
		V _{GS} =4.5V, I _D =10A		4.2	5.5	
Forward Transconductance	g _{FS}	V _{DS} =15, I _D =10A		75		S
Diode Forward Voltage	V _{SD}	I _S =5A, V _{GS} =0V		0.75	1.2	V
Dynamic						
Total Gate Charge	Q _g	V _{DS} =30V, V _{GS} =4.5V I _D ≧10A		56	70	nC
Gate-Source Charge	Q _{gs}			16	32	
Gate-Drain Charge	Q _{gd}			4		
Gate Resistance	R _g	f=1MHz	0.4	2.2	4.0	Ω
Input Capacitance	C _{iss}	V _{DS} =30V, V _{GS} =0V f=1MHz		3458		pF
Output Capacitance	C _{oss}			1255		
Reverse Transfer Capacitance	C _{rss}			22		
Turn-On Time	t _{d(on)}	V _{DD} =30V, R _L =3.0Ω I _D ≧10A, V _{GEN} =10V R _G =1Ω		15	30	ns
	t _r			8	16	
Turn-Off Time	t _{d(off)}			30	60	
	t _f			8	16	



Typical Characteristics

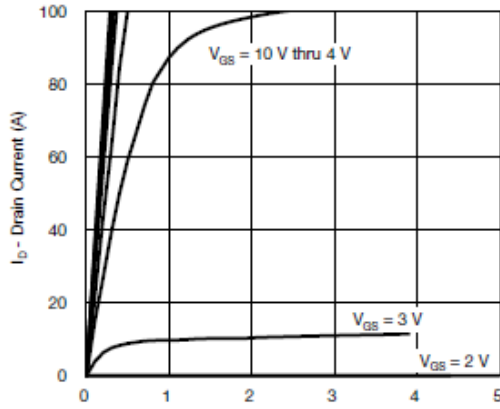

Output Characteristics

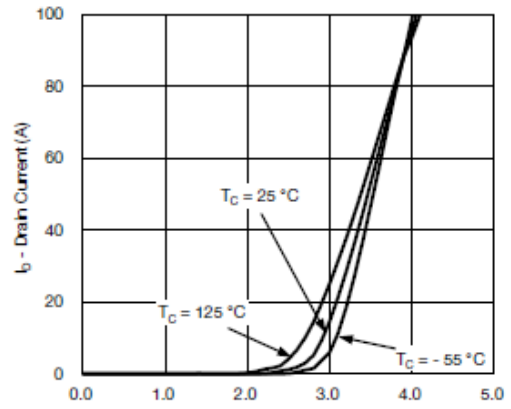

Transfer Characteristics

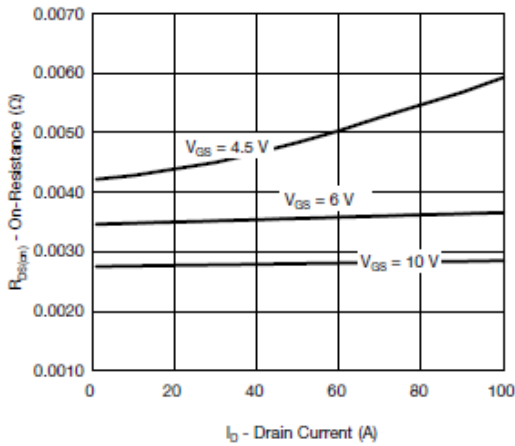

On-Resistance vs. Drain Current and Gate Voltage

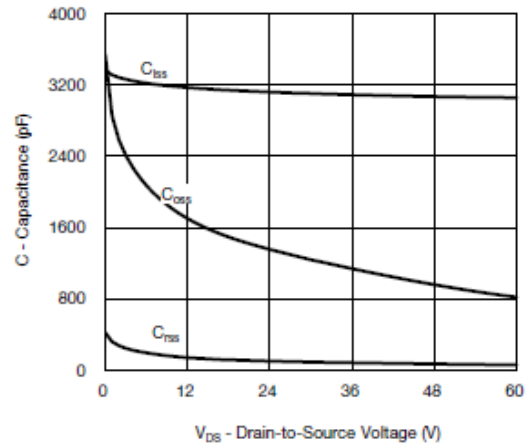

Capacitance

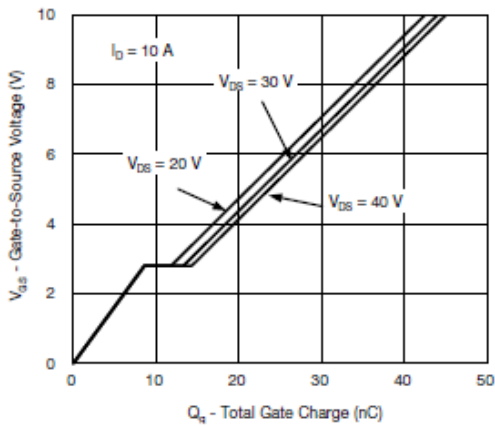

Gate Charge

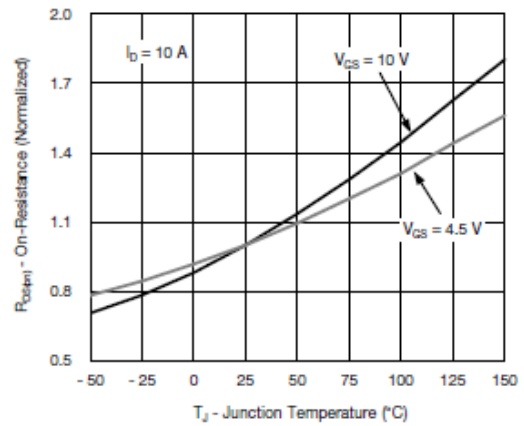

On-Resistance vs. Junction Temperature



Typical Characteristics

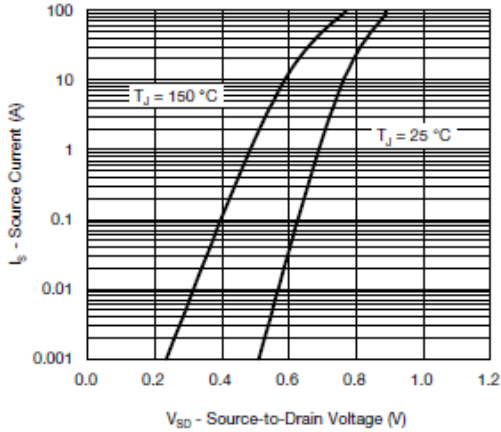

Source-Drain Diode Forward Voltage

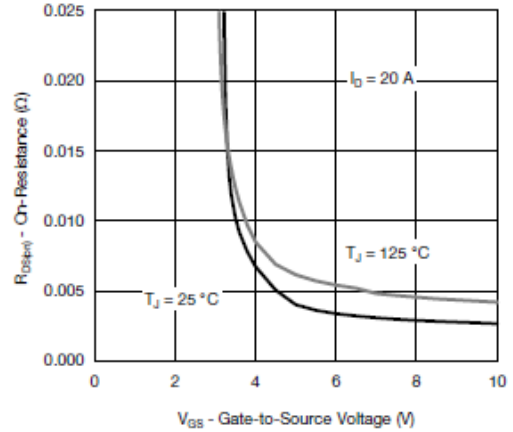

On-Resistance vs. Gate-to-Source Voltage

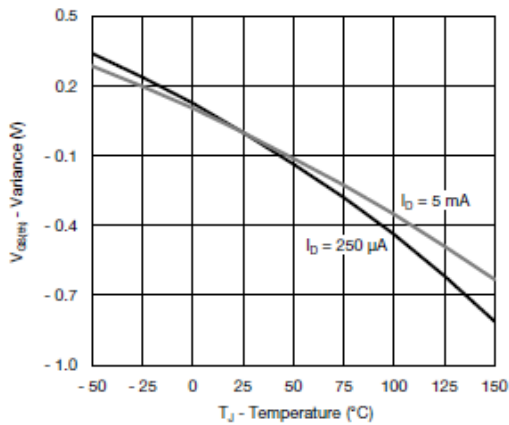

Threshold Voltage

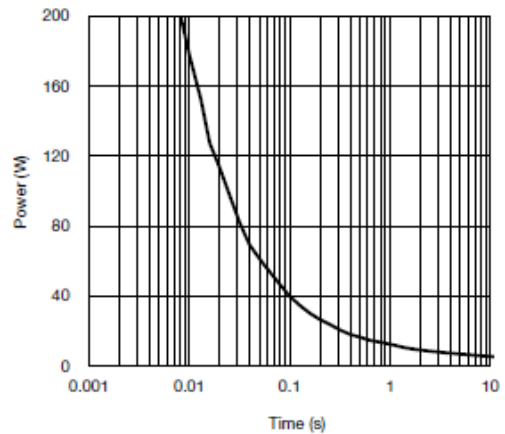

Single Pulse Power, Junction-to-Ambient

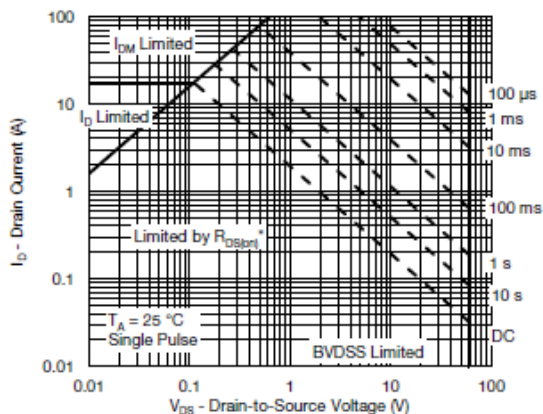

Safe Operating Area, Junction-to-Ambient

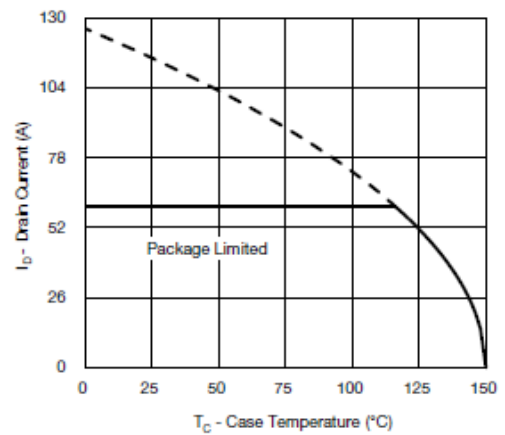

Current Derating*



Typical Characteristics

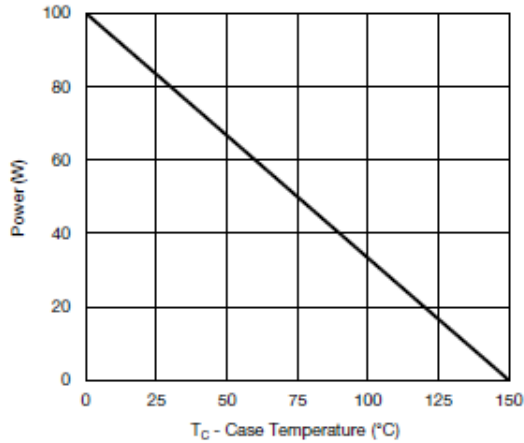

Power, Junction-to-Case

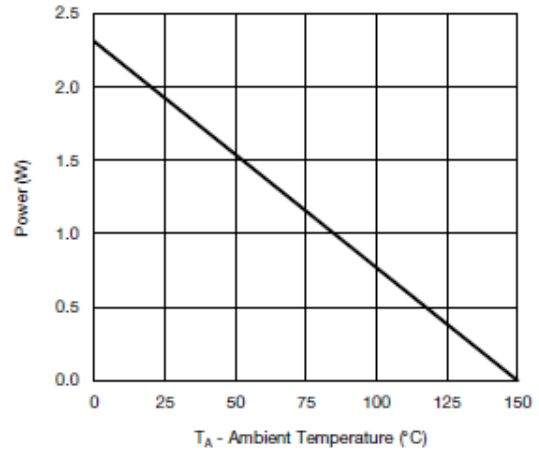

Power, Junction-to-Ambient

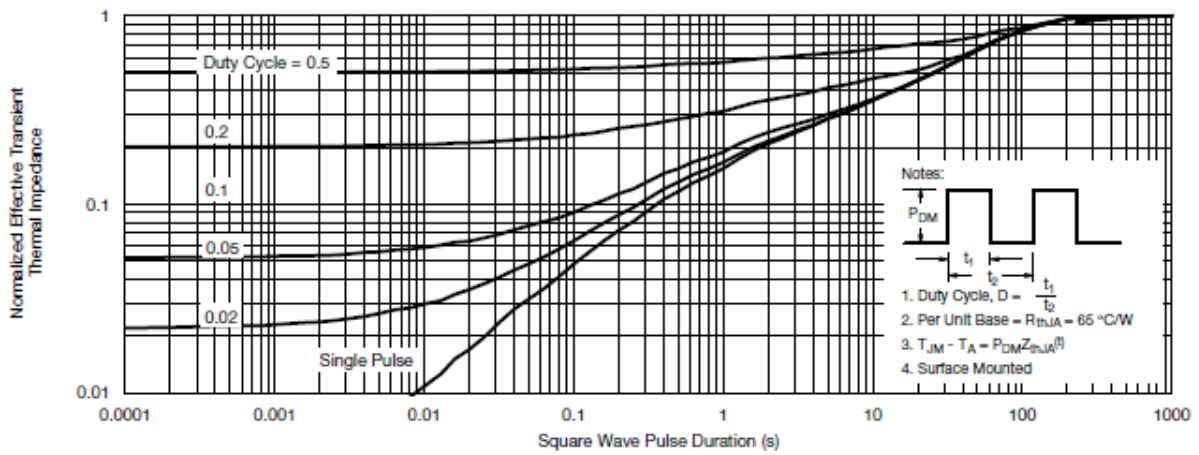

Normalized Thermal Transient Impedance, Junction-to-Ambient

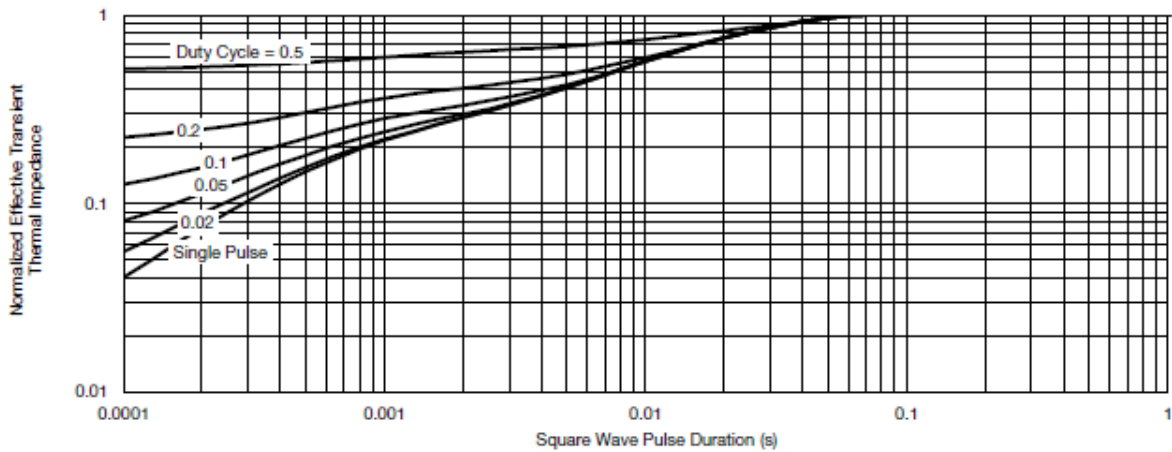



Typical Characteristics

Gate Charge Test Circuit & Waveform



Resistive Switching Test Circuit & Waveforms



Unclamped Inductive Switching Test Circuit & Waveforms





Package Information (DFN5X6-8L)

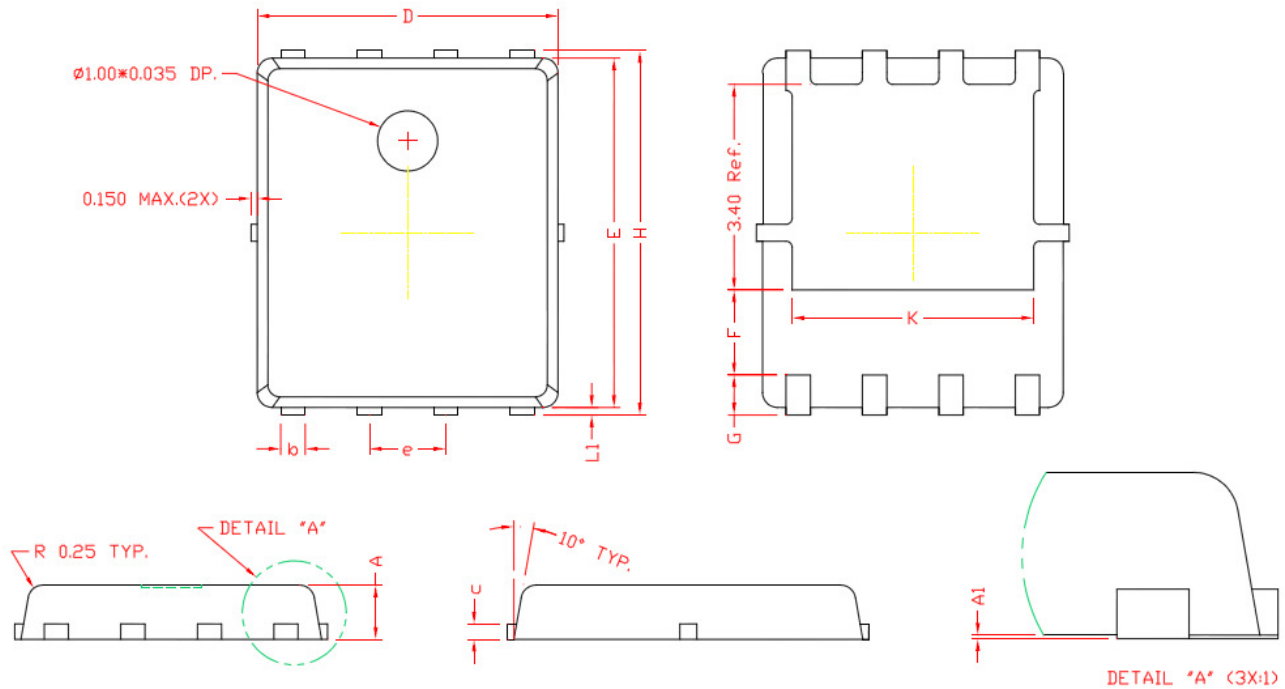

DIMENSIONS

REF.	Millimeters		REF.	Millimeters	
	Min.	Max.		Min.	Max.
A	0.80	1.00	E	5.70	5.90
A1	0.00	0.05	e	1.27 BSC.	
b	0.35	0.49	H	5.95	6.20
c	0.254 Ref.		L1	0.10	0.18
D	4.90	5.10	G	0.60 Ref.	
F	1.40 Ref.		K	4.00 Ref.	

©2010 Alfa-MOS Technology Corp.
 2F, No.80, Sec.1, Cheng Kung Rd., Nan Kang Dist., Taipei City 115, Taiwan (R.O.C.)
 Tel : 886 2) 2651 3928
 Fax : 886 2) 2786 8483
 ©http://www.alfa-mos.com