

General Description

AFN7002LKAS, N-Channel enhancement mode MOSFET, uses Advanced Trench Technology to provide excellent $R_{DS(ON)}$, low gate charge.

These devices are particularly suited for low voltage power management, such as smart phone and notebook computer and other battery powered circuits, and low in-line power loss are needed in commercial industrial surface mount applications.

Features

- $I_D=0.50A$, $R_{DS(ON)}=1600m\Omega@V_{GS}=10V$
- $I_D=0.40A$, $R_{DS(ON)}=2500m\Omega@V_{GS}=4.5V$
- $I_D=0.05A$, $R_{DS(ON)}=4500m\Omega@V_{GS}=2.5V$
- Super high density cell design for extremely low RDS (ON)
- Exceptional on-resistance and maximum DC current capability
- ESD Protection Diode design-in
- SOT-23 package design

Pin Description (SOT-23)

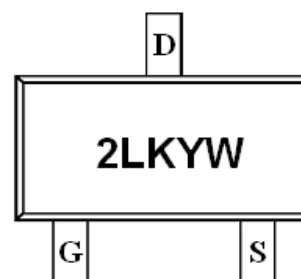
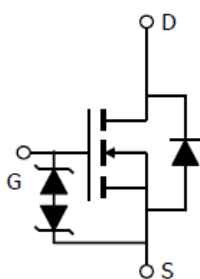
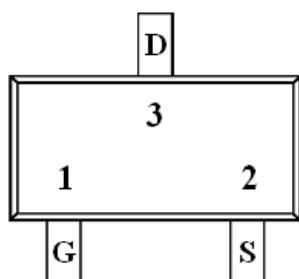

Application

- Drivers: Relays, Solenoids, Lamps, Hammers, Display, Memories, Transistors, etc.
- High saturation current capability. Direct Logic-Level Interface: TTL/CMOS
- Battery Operated Systems
- Solid-State Relays

Pin Define

Pin	Symbol	Description
1	G	Gate
2	S	Source
3	D	Drain

Ordering Information

Part Ordering No.	Part Marking	Package	Unit	Quantity
AFN7002LKASS23RG	2LKYW	SOT-23	Tape & Reel	3000 EA

- ※ 2LK Parts code
- ※ Y Year code (0 ~ 9)
- ※ W Week code (A ~ Z = 1 ~ 26 / a ~ z = 27 ~ 52)
- ※ AFN7002LKASS23RG : 7" Tape & Reel ; Pb- Free ; Halogen -Free



Absolute Maximum Ratings

(T_A=25°C Unless otherwise noted)

Parameter	Symbol	Value	Unit
Drain-Source Voltage	V _{DSS}	60	V
Gate –Source Voltage	V _{GSS}	±20	V
Continuous Drain Current(T _J =150°C)	I _D	T _A =25°C	0.5
		T _A =70°C	0.2
Pulsed Drain Current	I _{DM}	0.65	A
Continuous Source Current(Diode Conduction)	I _S	0.45	A
Power Dissipation	P _D	T _A =25°C	1.25
		T _A =70°C	0.8
Operating Junction Temperature	T _J	150	°C
Storage Temperature Range	T _{STG}	-55/150	°C
Thermal Resistance-Junction to Ambient	R _{θJA}	120	°C/W

Electrical Characteristics

(T_A=25°C Unless otherwise noted)

Parameter	Symbol	Conditions	Min.	Typ	Max.	Unit
Static						
Drain-Source Breakdown Voltage	V _{(BR)DSS}	V _{GS} =0V, I _D =250uA	60			V
Gate Threshold Voltage	V _{GS(th)}	V _{DS} =V _{GS} , I _D =250uA	0.7	1.0	1.3	
Gate Leakage Current	I _{GSS}	V _{DS} =0V, V _{GS} =±20V			5	uA
Zero Gate Voltage Drain Current	I _{DSS}	V _{DS} =48V, V _{GS} =0V			1	uA
		V _{DS} =48V, V _{GS} =0V T _J =85°C			10	
Drain-Source On-Resistance	R _{DS(on)}	V _{GS} =10V, I _D =0.50A		950	1600	mΩ
		V _{GS} = 4.5V, I _D =0.40A		1250	2500	
		V _{GS} = 2.5V, I _D =0.05A		2650	4500	
Forward Transconductance	g _{FS}	V _{DS} =10V, I _D =0.2A		0.2		S
Diode Forward Voltage	V _{SD}	I _S =0.2A, V _{GS} =0V		0.82	1.4	V
Dynamic						
Total Gate Charge	Q _g	V _{DS} =30V, V _{GS} =10V I _D ≧0.25A		1.5	2.5	pC
Gate-Source Charge	Q _{gs}			0.2		
Gate-Drain Charge	Q _{gd}			0.5		
Input Capacitance	C _{iss}	V _{DS} =25V, V _{GS} =0V f=1MHz		28		pF
Output Capacitance	C _{oss}			10		
Reverse Transfer Capacitance	C _{rss}			5		
Turn-On Time	t _{d(on)}	V _{DD} =30V, R _G =6Ω I _D ≧0.25A, V _{GEN} =10V		3	7	ns
	t _r			12	30	
Turn-Off Time	t _{d(off)}			18	40	
	t _f			8	15	



Typical Characteristics

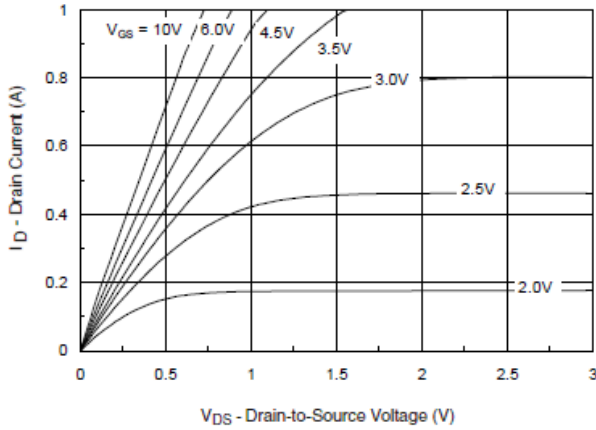

Output Characteristics

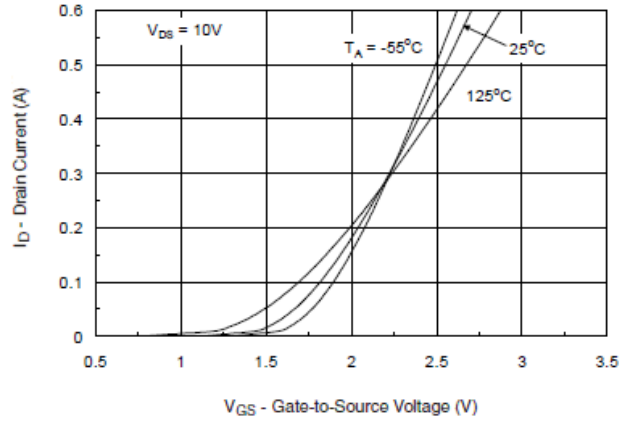

Transfer Characteristics

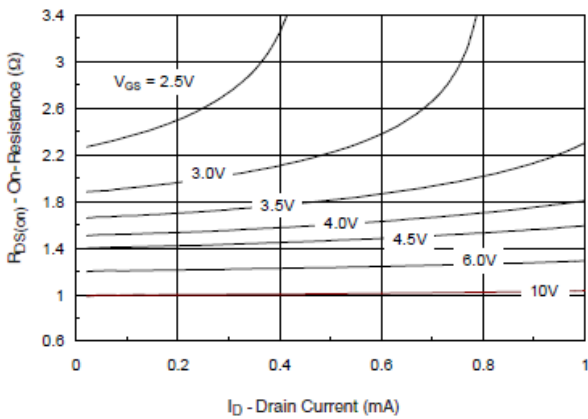

On-Resistance vs. Drain Current

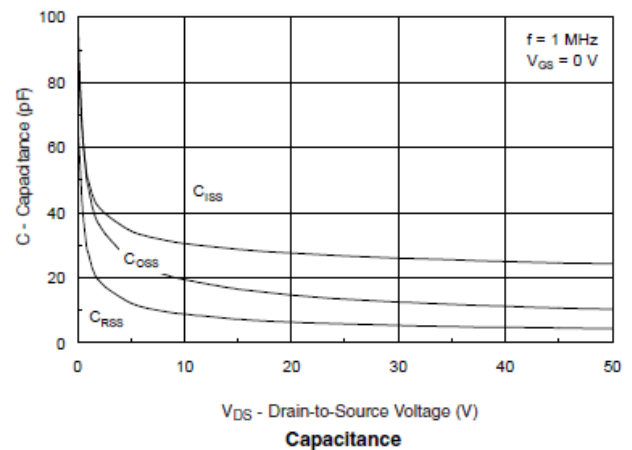

Capacitance

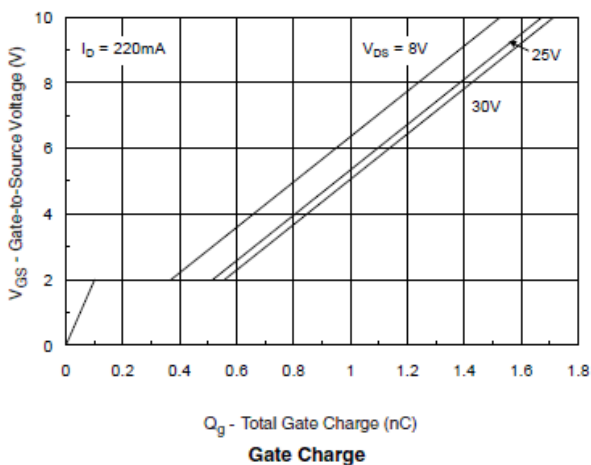

Gate Charge

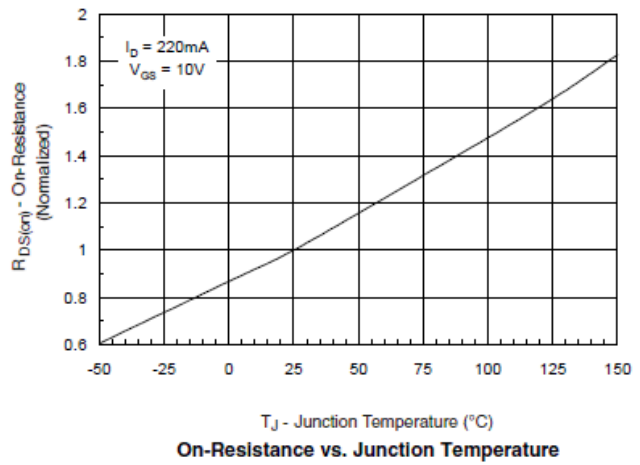

On-Resistance vs. Junction Temperature



Typical Characteristics

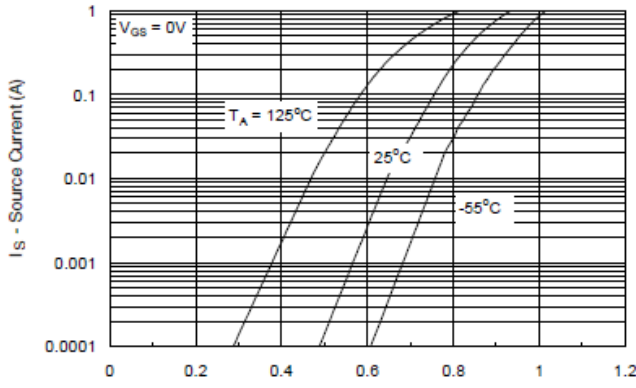

Source-Drain Diode Forward Voltage

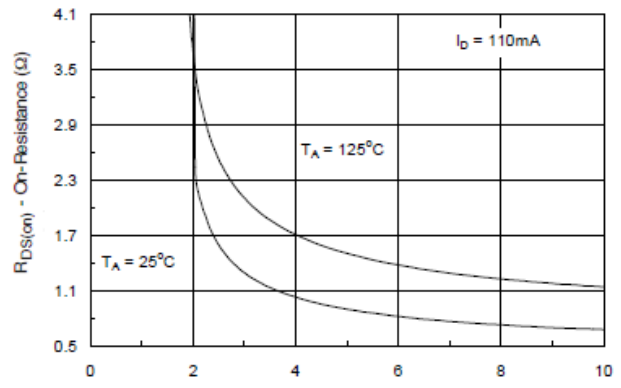

On-Resistance vs. Gate-to-Source Voltage

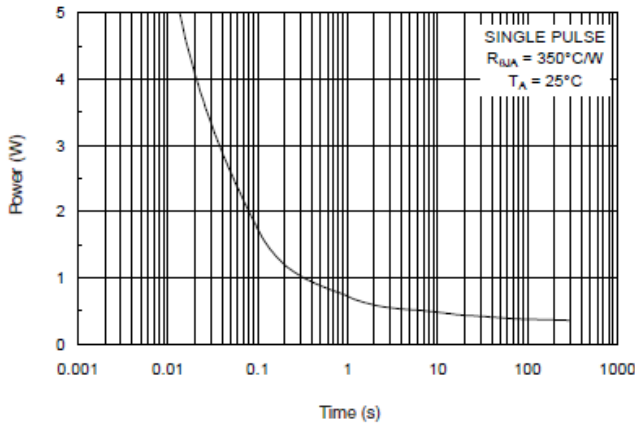

Single Pulse Power

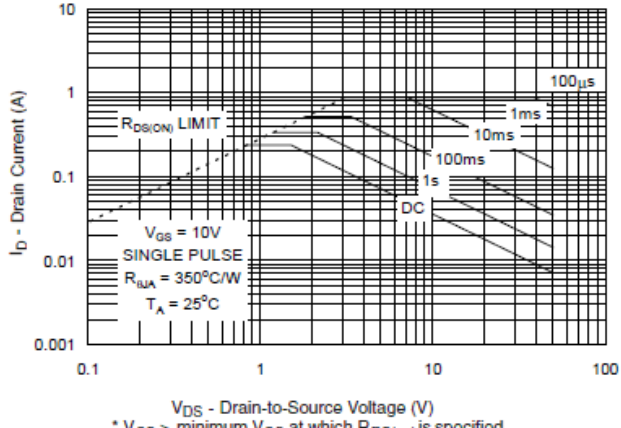

Safe Operating Area

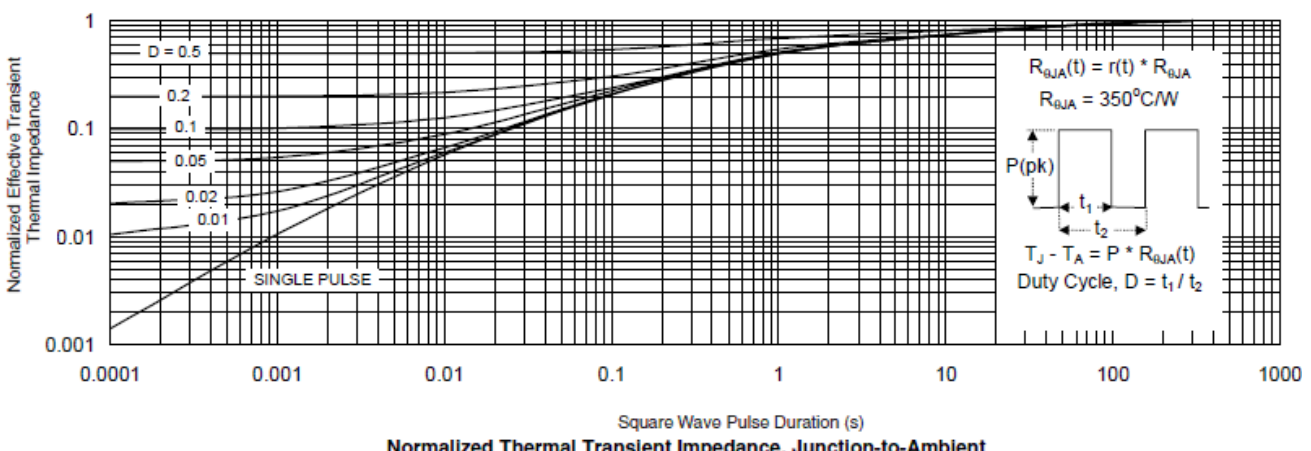

Normalized Thermal Transient Impedance, Junction-to-Ambient



Typical Characteristics

Gate Charge Test Circuit & Waveform



Resistive Switching Test Circuit & Waveforms



Unclamped Inductive Switching Test Circuit & Waveforms





Package Information (SOT-23)

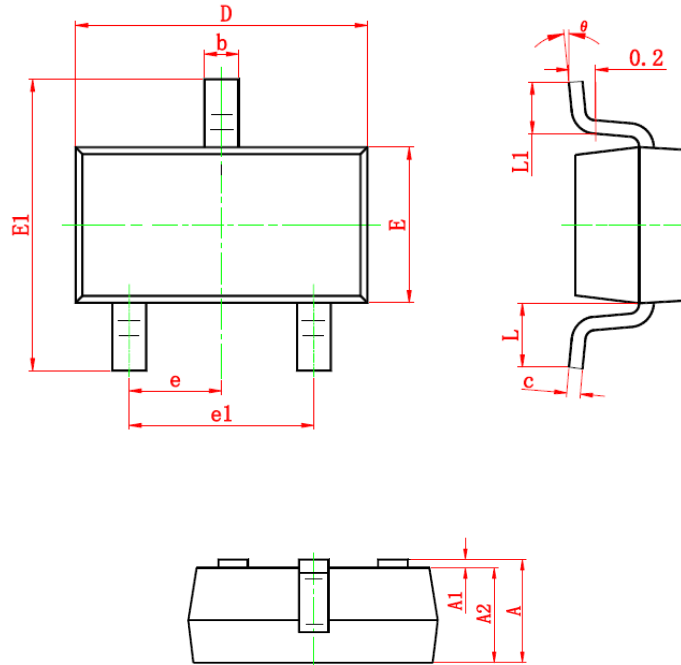

Symbol	Dimensions In Millimeters		Dimensions In Inches	
	Min	Max	Min	Max
A	0.900	1.200	0.035	0.043
A1	0.000	0.100	0.000	0.004
A2	0.900	1.100	0.035	0.039
b	0.300	0.500	0.012	0.020
c	0.080	0.150	0.003	0.006
D	2.800	3.000	0.110	0.118
E	1.200	1.400	0.047	0.055
E1	2.250	2.550	0.089	0.100
e	0.950 TYP		0.037 TYP	
e1	1.800	2.000	0.071	0.079
L	0.550 REF		0.022 REF	
L1	0.300	0.500	0.012	0.020
theta	0°	8°	0°	6°

©2010 Alfa-MOS Technology Corp.
 2F, No.80, Sec.1, Cheng Kung Rd., Nan Kang Dist., Taipei City 115, Taiwan (R.O.C.)
 Tel : 886 2) 2651 3928
 Fax : 886 2) 2786 8483
 ©http://www.alfa-mos.com