



General Description

AFN7472S, N-Channel enhancement mode MOSFET, uses Advanced Trench Technology to provide excellent $R_{DS(ON)}$, low gate charge.

These devices are particularly suited for low voltage power management, such as smart phone and notebook computer and other battery powered circuits, and low in-line power loss are needed in commercial industrial surface mount applications.

Features

- $I_D=15A, R_{DS(ON)}=8.6m\Omega@V_{GS}=10V$
- $I_D=13A, R_{DS(ON)}=14m\Omega@V_{GS}=4.5V$
- Super high density cell design for extremely low $R_{DS(ON)}$
- Exceptional on-resistance and maximum DC current capability
- DFN3.3X3.3-8L package design

Pin Description (DFN3.3X3.3-8L)

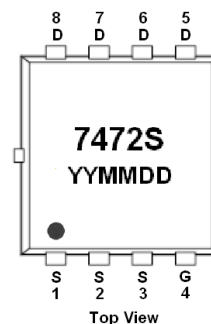
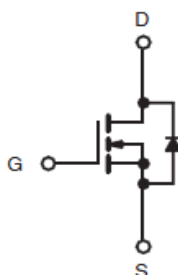
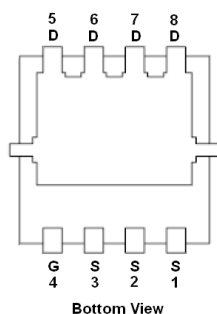

Application

- DC-DC Converter
- POL

Pin Define

Pin	Symbol	Description
1	S	Source
2	S	Source
3	S	Source
4	G	Gate
5	D	Drain
6	D	Drain
7	D	Drain
8	D	Drain

Ordering Information

Part Ordering No.	Part Marking	Package	Unit	Quantity
AFN7472SFN308RG	7472S	DFN3.3X3.3-8L	Tape & Reel	5000 EA

※ YY year code

※ MM month code

※ DD date code

※ AFN7472SFN308RG : 13" Tape & Reel ; Pb- Free ; Halogen -Free



Absolute Maximum Ratings

(T_A=25°C Unless otherwise noted)

Parameter	Symbol	Value	Unit
Drain-Source Voltage	V _{DSS}	30	V
Gate –Source Voltage	V _{GSS}	±20	V
Continuous Drain Current(T _J =150°C)	I _D	T _A =25°C	15
		T _A =70°C	12
Pulsed Drain Current	I _{DM}	70	A
Continuous Source Current(Diode Conduction)	I _S	20	A
Power Dissipation	P _D	T _C =25°C	28
		T _C =70°C	15
		T _A =25°C	3.1
		T _A =70°C	2.0
Operating Junction Temperature	T _J	150	°C
Storage Temperature Range	T _{STG}	-55/150	°C
Thermal Resistance Junction-to-Case (Drain)	R _{θJC}	5	°C/W
Thermal Resistance-Junction to Ambient	R _{θJA}	40	

Electrical Characteristics

(T_A=25°C Unless otherwise noted)

Parameter	Symbol	Conditions	Min.	Typ	Max.	Unit
Static						
Drain-Source Breakdown Voltage	V _{(BR)DSS}	V _{GS} =0V, I _D =250uA	30			V
Gate Threshold Voltage	V _{GS(th)}	V _{DS} =V _{GS} , I _D =250uA	1.0		2.0	
Gate Leakage Current	I _{GSS}	V _{DS} =0V, V _{GS} =±20V			±100	nA
Zero Gate Voltage Drain Current	I _{DSS}	V _{DS} =24V, V _{GS} =0V			1	uA
		V _{DS} =24V, V _{GS} =0V T _J =85°C			10	
On-State Drain Current	I _{D(on)}	V _{DS} ≥ 5V, V _{GS} =10V	20			A
Drain-Source On-Resistance	R _{DS(on)}	V _{GS} =10V, I _D =20A		7.6	8.6	mΩ
		V _{GS} =4.5V, I _D =15A		11	14	
Forward Transconductance	g _{FS}	V _{DS} =15V, I _D =13 A		50		S
Diode Forward Voltage	V _{SD}	I _S =10A, V _{GS} =0V		0.8	1.3	V
Dynamic						
Total Gate Charge	Q _g	V _{DS} =15V, V _{GS} =4.5V I _D ≡15A		10	20	nC
Gate-Source Charge	Q _{gs}			3.8		
Gate-Drain Charge	Q _{gd}			3.8		
Input Capacitance	C _{iss}	V _{DS} =15V, V _{GS} =0V f=1MHz		995		pF
Output Capacitance	C _{oss}			190		
Reverse Transfer Capacitance	C _{rss}			125		
Turn-On Time	t _{d(on)}	V _{DD} =15V, R _L =1.5Ω I _D ≡10A, V _{GEN} =10V R _G =1.0Ω		10	20	ns
	t _r			10	20	
Turn-Off Time	t _{d(off)}			20	35	
	t _f			8	15	



Typical Characteristics

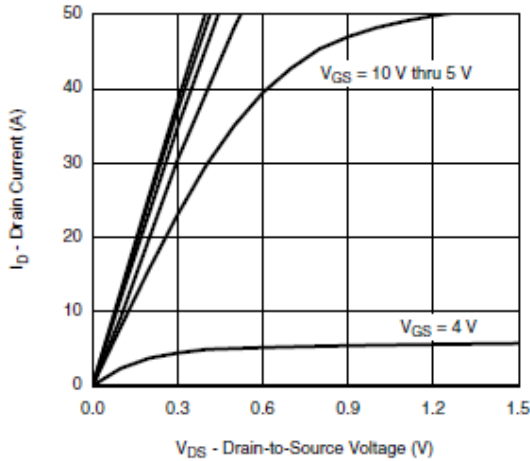

Output Characteristics

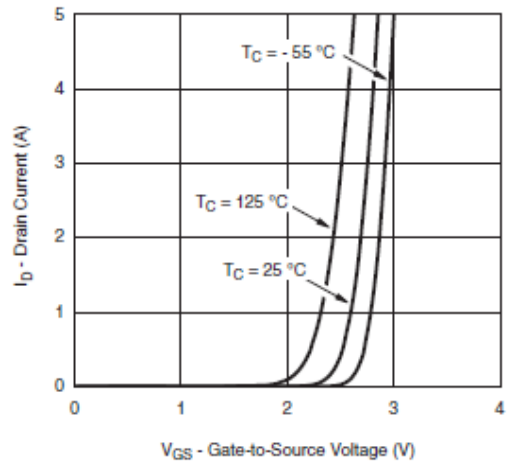

Transfer Characteristics

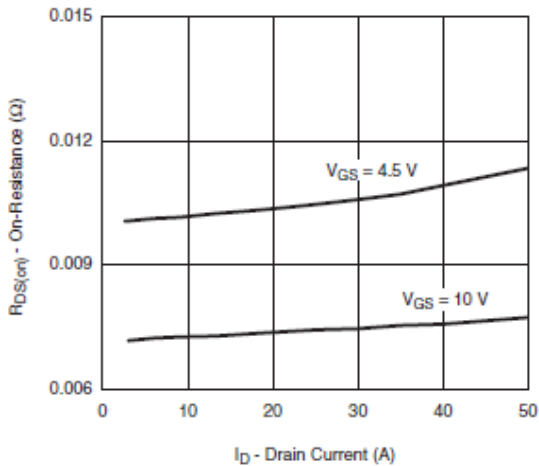

On-Resistance vs. Drain Current and Gate Voltage

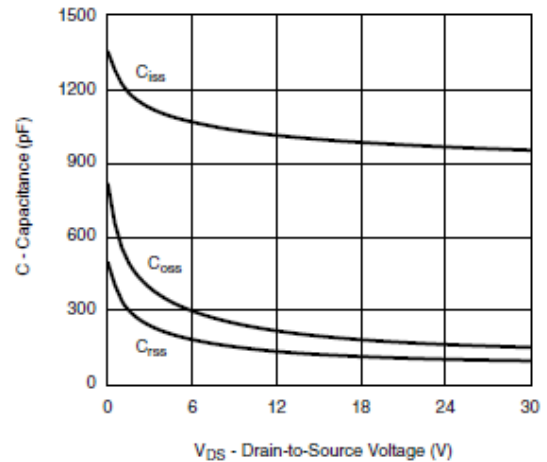

Capacitance

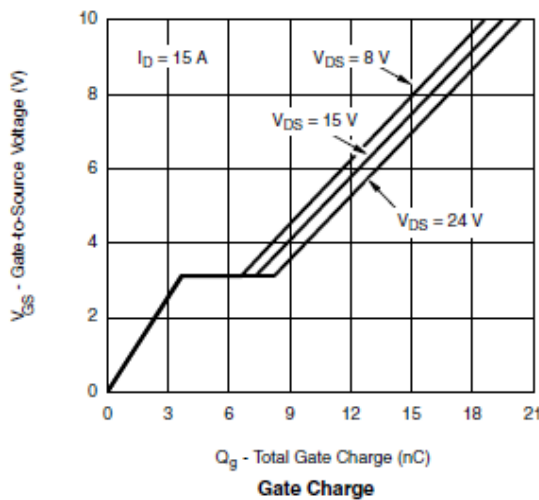

Gate Charge

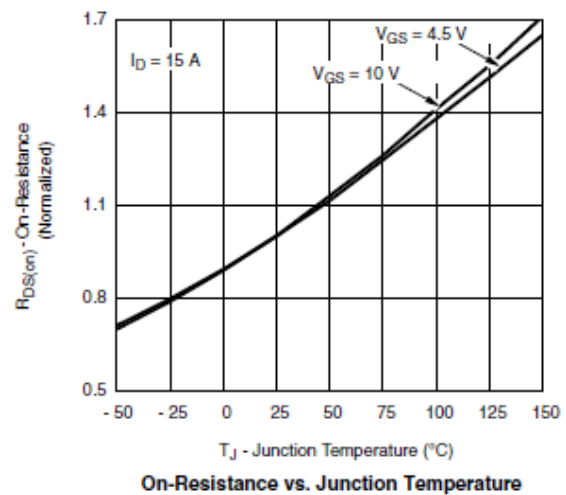

On-Resistance vs. Junction Temperature



Typical Characteristics

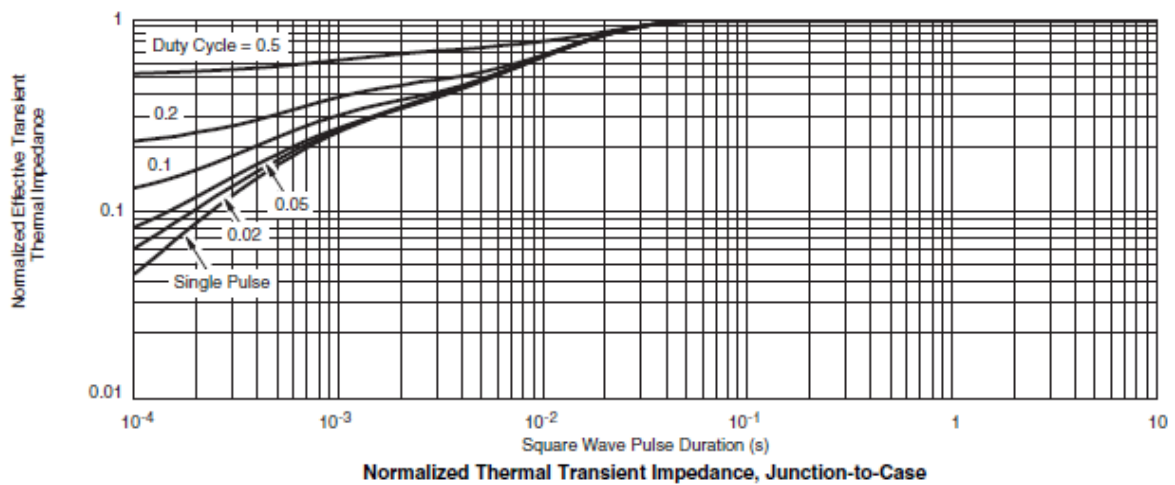
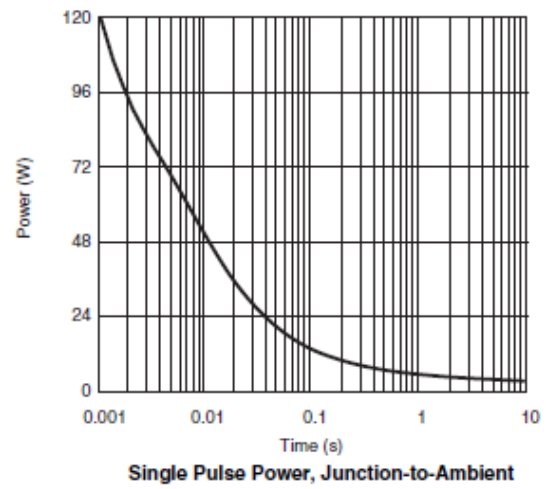
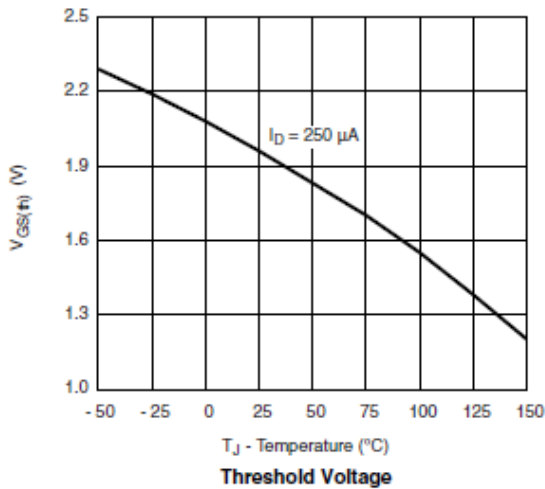
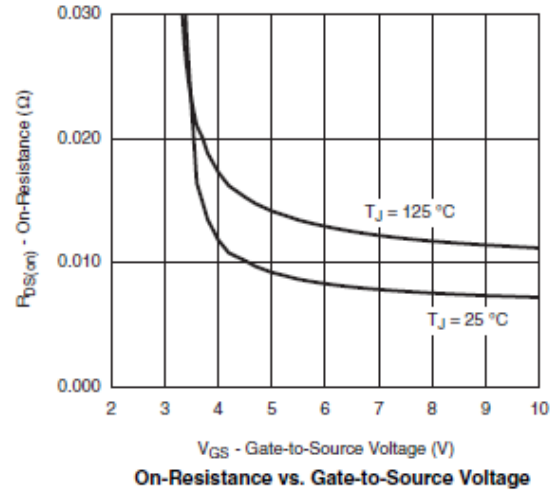
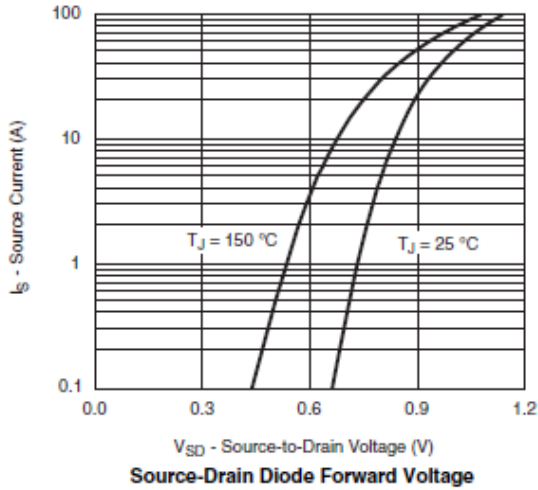



Typical Characteristics

Gate Charge Test Circuit & Waveform

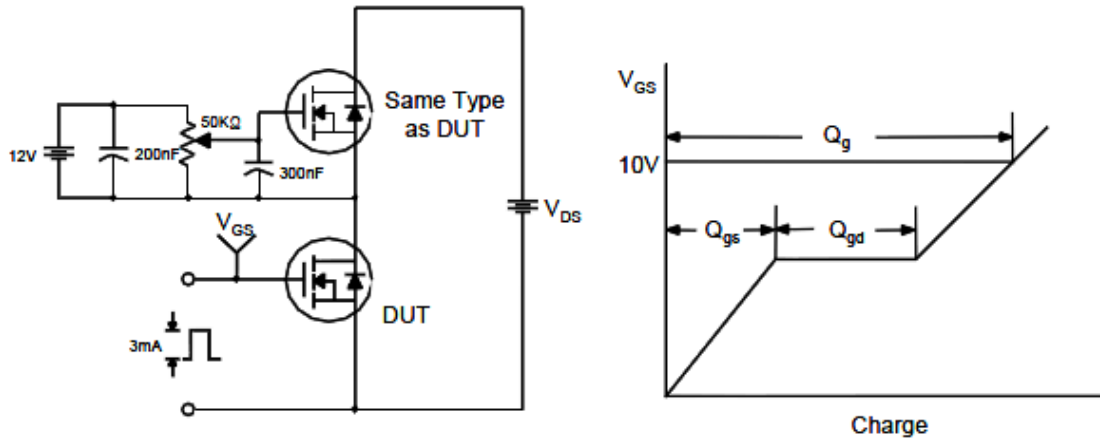

Resistive Switching Test Circuit & Waveforms

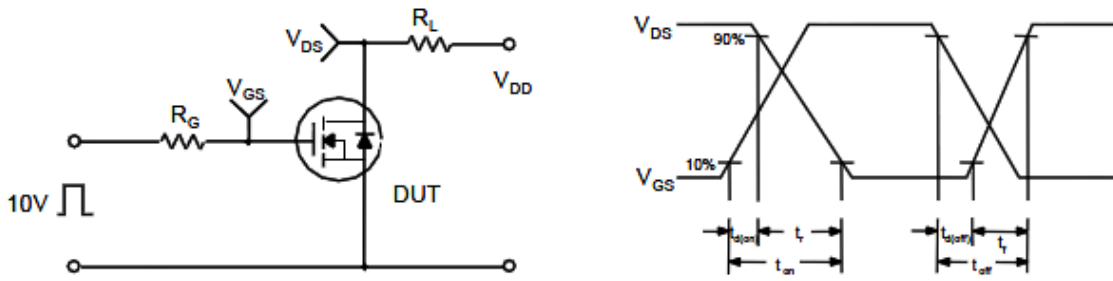

Unclamped Inductive Switching Test Circuit & Waveforms

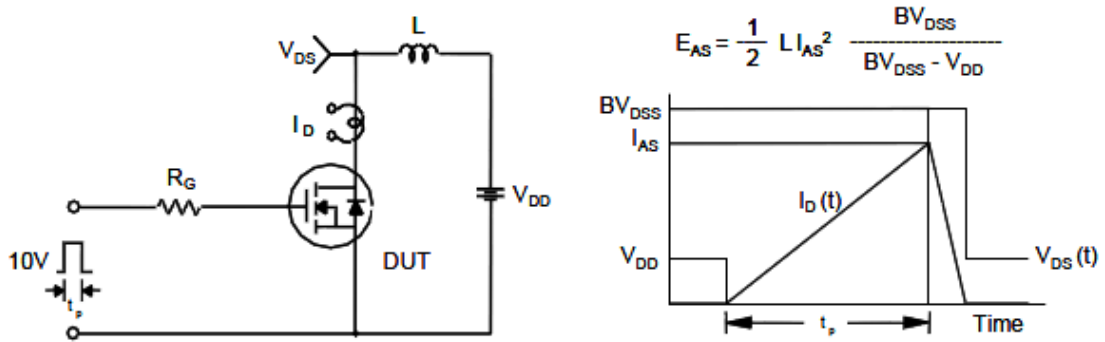



Package Information (DFN3.3X3.3-8L)

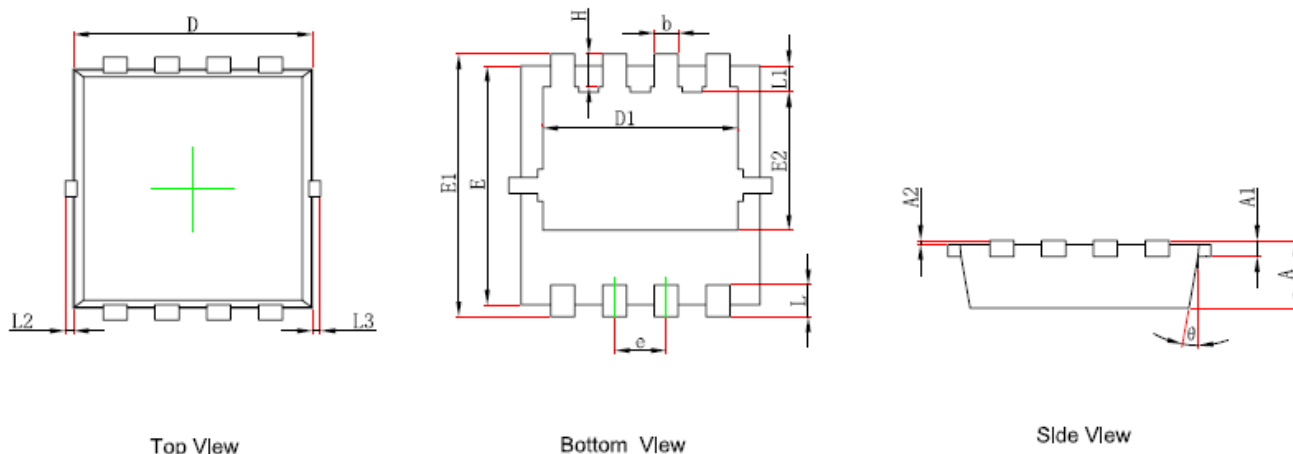

Symbol	Dimensions In Millimeters		Dimensions In Inches	
	Min.	Max.	Min.	Max.
A	0.650	0.850	0.026	0.033
A1	0.152 REF.		0.006 REF.	
A2	0~0.05		0~0.002	
D	2.900	3.100	0.114	0.122
D1	2.300	2.600	0.091	0.102
E	2.900	3.100	0.114	0.122
E1	3.150	3.450	0.124	0.136
E2	1.535	1.935	0.060	0.076
b	0.200	0.400	0.008	0.016
e	0.550	0.750	0.022	0.030
L	0.300	0.500	0.012	0.020
L1	0.180	0.480	0.007	0.019
L2	0~0.100		0~0.004	
L3	0~0.100		0~0.004	
H	0.315	0.515	0.012	0.020
θ	9°	13°	9°	13°

©2010 Alfa-MOS Technology Corp.
 2F, No.80, Sec.1, Cheng Kung Rd., Nan Kang Dist., Taipei City 115, Taiwan (R.O.C.)
 Tel : 886 2) 2651 3928
 Fax : 886 2) 2786 8483
 ©http://www.alfa-mos.com