



General Description

AFN8478S, N-Channel enhancement mode MOSFET, uses Advanced Trench Technology to provide excellent $R_{DS(ON)}$, low gate charge.

These devices are particularly suited for low voltage power management, and low in-line power loss are needed in commercial industrial surface mount applications.

Features

- $I_D=15A, R_{DS(ON)}= 8.5m\Omega@V_{GS}=10V$
- $I_D=10A, R_{DS(ON)}=12.5m\Omega@V_{GS}=4.5V$
- Super high density cell design for extremely low $R_{DS(ON)}$
- DFN5X6-8L package design

Pin Description (DFN5X6-8L)

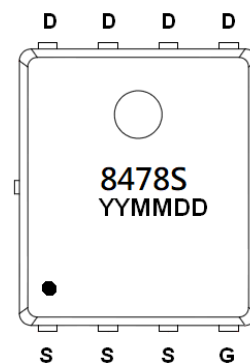
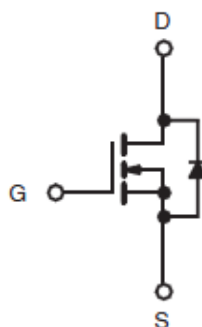
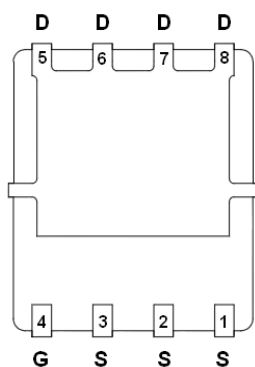

Application

- Networking / Telecom / Server
- LED Lighting Applications
- Quick Charger Applications
- DC-DC Primary Side Switch

Pin Define

Pin	Symbol	Description
1~3	S	Source
4	G	Gate
5~8	D	Drain

Ordering Information

Part Ordering No.	Part Marking	Package	Unit	Quantity
AFN8478SFN568RG	8478S	DFN5X6-8L	Tape & Reel	2500 EA

- ※ 8478S : Parts Code
- ※ YYMMDD : Date Code
- ※ AFN8478SFN568RG : 13" Tape & Reel ; Pb- Free ; Halogen- Free



Absolute Maximum Ratings

($T_A=25^\circ\text{C}$ Unless otherwise noted)

Parameter	Symbol	Typical	Unit
Drain-Source Voltage	V_{DS}	80	V
Gate –Source Voltage	V_{GS}	± 20	V
Continuous Drain Current($T_J=150^\circ\text{C}$)	I_{DSM}	$T_C=25^\circ\text{C}$	60
		$T_C=70^\circ\text{C}$	52
Pulsed Drain Current ($t=100\mu\text{s}$)	I_{DM}	$T_A=25^\circ\text{C}$	18
		$T_A=70^\circ\text{C}$	15
Continuous Source Current(Diode Conduction)	I_S	$T_C=25^\circ\text{C}$	60
		$T_A=25^\circ\text{C}$	4.5
Single Pulse Avalanche Current	I_{AS}	$L=0.1\text{mH}$	30
			E_{AS}
Power Dissipation	P_D	$T_C=25^\circ\text{C}$	62.5
		$T_C=75^\circ\text{C}$	40
Operating Junction Temperature	T_J	$T_A=25^\circ\text{C}$	5.0
		$T_A=75^\circ\text{C}$	3.2
Storage Temperature Range	T_{STG}	-55/150	$^\circ\text{C}$
Thermal Resistance-Junction to Ambient	$R_{\theta JA}$	20	$^\circ\text{C/W}$
Maximum Junction-to-Case (Drain)	$R_{\theta JA}$	1.5	

Electrical Characteristics

($T_A=25^\circ\text{C}$ Unless otherwise noted)

Parameter	Symbol	Conditions	Min.	Typ	Max.	Unit
Static						
Drain-Source Breakdown Voltage	$V_{(BR)DSS}$	$V_{GS}=0V, I_D=250\mu\text{A}$	80			V
Gate Threshold Voltage	$V_{GS(th)}$	$V_{DS}=V_{GS}, I_D=250\mu\text{A}$	1.0		2.5	
Gate Leakage Current	I_{GSS}	$V_{DS}=0V, V_{GS}=\pm 20V$			± 100	nA
Zero Gate Voltage Drain Current	I_{DSS}	$V_{DS}=64V, V_{GS}=0V$			1	uA
		$V_{DS}=64V, V_{GS}=0V$ $T_J=85^\circ\text{C}$			10	
On-State Drain Current	$I_{D(on)}$	$V_{DS} \geq 5V, V_{GS}=10V$	30			A
Drain-Source On-Resistance	$R_{DS(on)}$	$V_{GS}=10V, I_D=15A$		7.2	8.5	m Ω
		$V_{GS}=4.5V, I_D=10A$		10.5	12.5	
Forward Transconductance	g_{FS}	$V_{DS}=10V, I_D=20A$		60		S
Diode Forward Voltage	V_{SD}	$I_S=5A, V_{GS}=0V$		0.75	1.2	V
Dynamic						
Total Gate Charge	Q_g	$V_{DS}=40V, V_{GS}=4.5V$ $I_D=10A$		18	36	nC
Gate-Source Charge	Q_{gs}			7.5		
Gate-Drain Charge	Q_{gd}			8.5		
Gate Resistance	R_g	$f=1\text{MHz}$	0.4	1.4	2.4	Ω
Input Capacitance	C_{iss}	$V_{DS}=40V, V_{GS}=0V$ $f=1\text{MHz}$		1850		pF
Output Capacitance	C_{oss}			950		
Reverse Transfer Capacitance	C_{rss}			75		
Turn-On Time	$t_{d(on)}$	$V_{DD}=40V, R_L=4.0\Omega$ $I_D=10A, V_{GEN}=10V$ $R_G=1\Omega$		12	24	ns
	t_r			8	16	
Turn-Off Time	$t_{d(off)}$			32	64	
	t_f			7	14	



Typical Characteristics

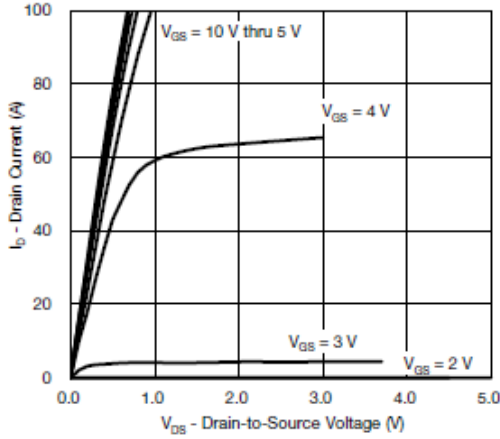

Output Characteristics

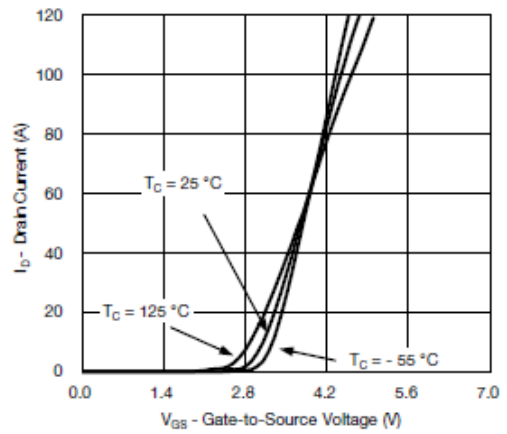

Transfer Characteristics

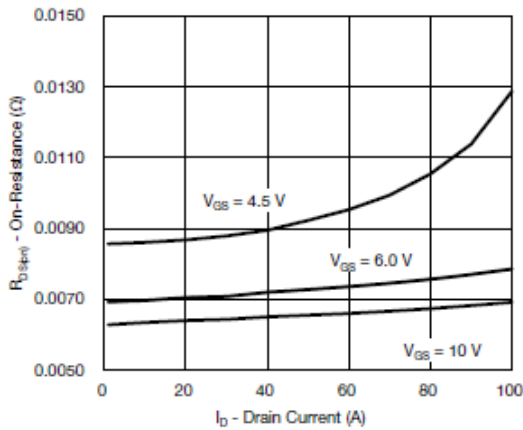

On-Resistance vs. Drain Current

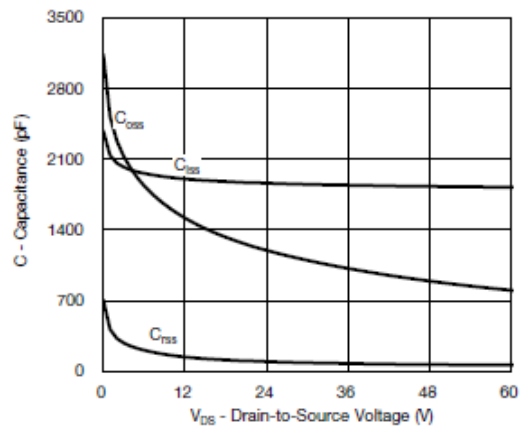

Capacitance

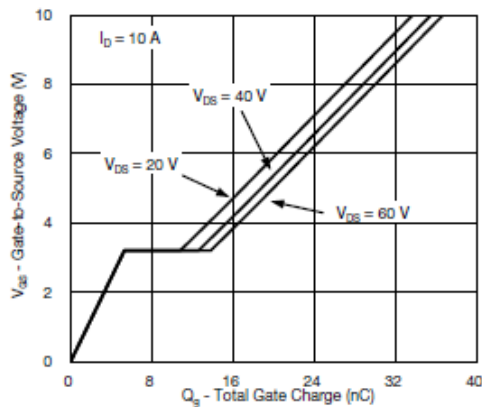

Gate Charge

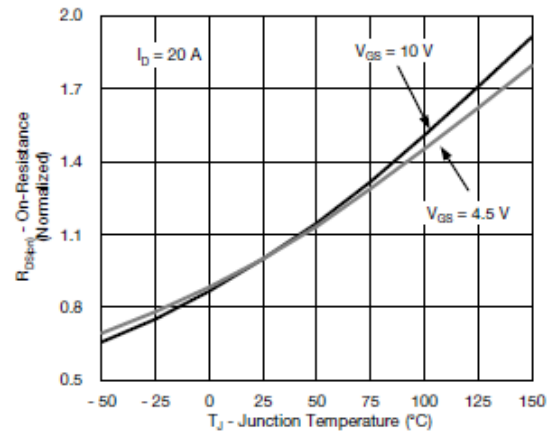

On-Resistance vs. Junction Temperature



Typical Characteristics

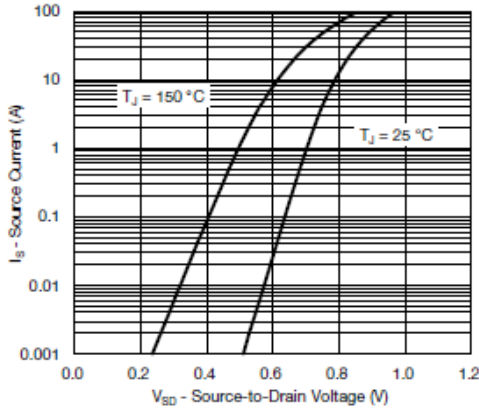

Source-Drain Diode Forward Voltage

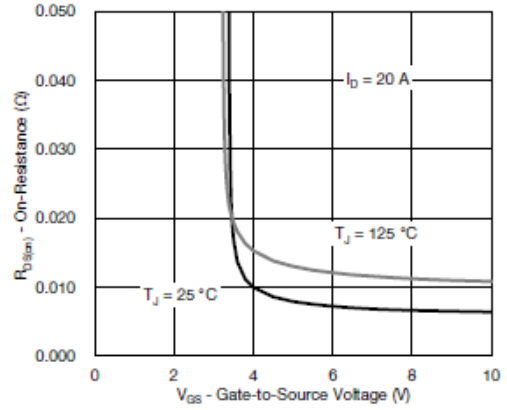

On-Resistance vs. Gate-to-Source Voltage

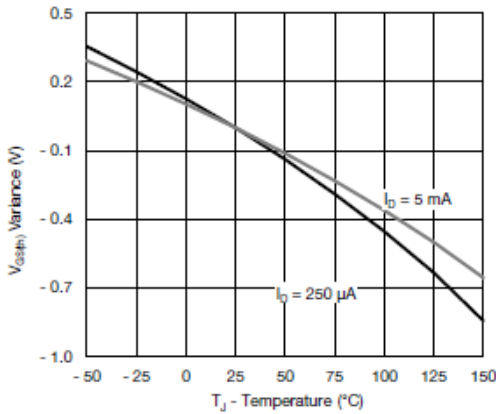

Threshold Voltage

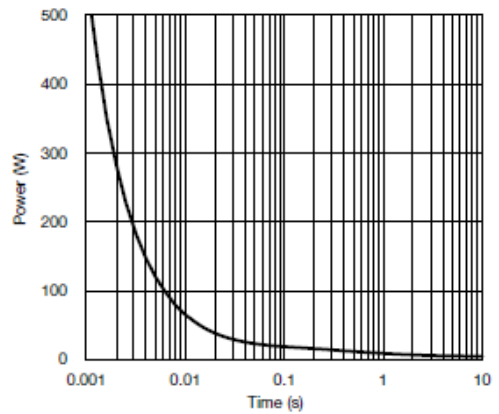

Single Pulse Power, Junction-to-Ambient

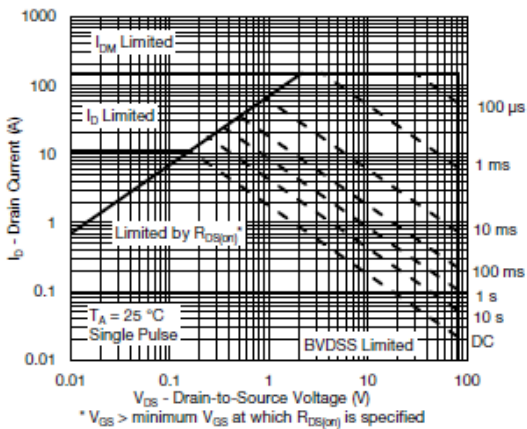

Safe Operating Area, Junction-to-Ambient

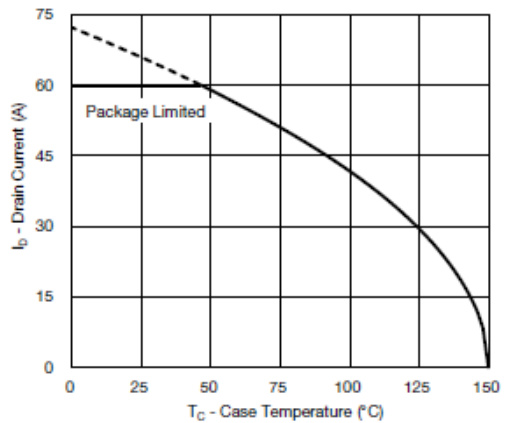

Current Derating ^a



Typical Characteristics

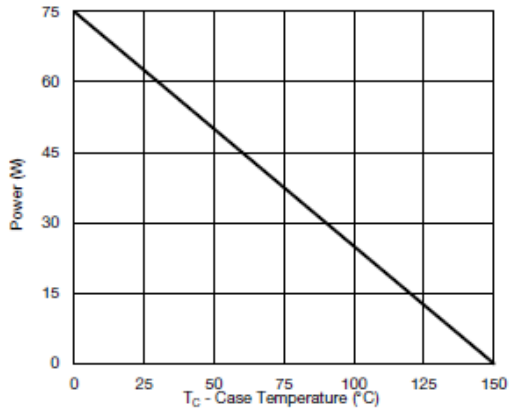

Power, Junction-to-Case

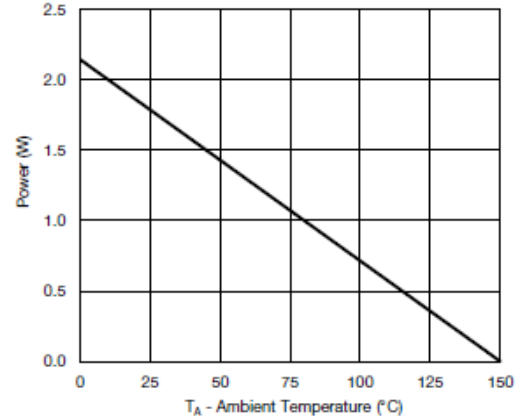

Power, Junction-to-Ambient

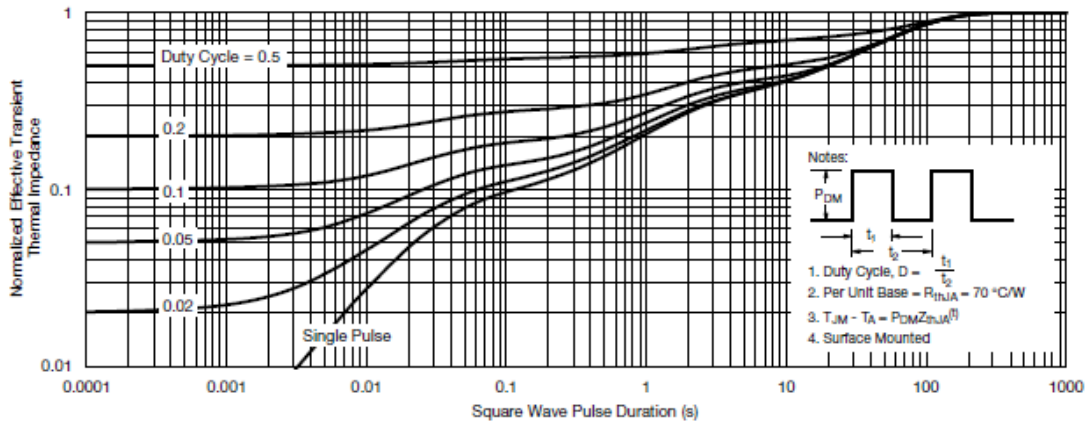

Normalized Thermal Transient Impedance, Junction-to-Ambient

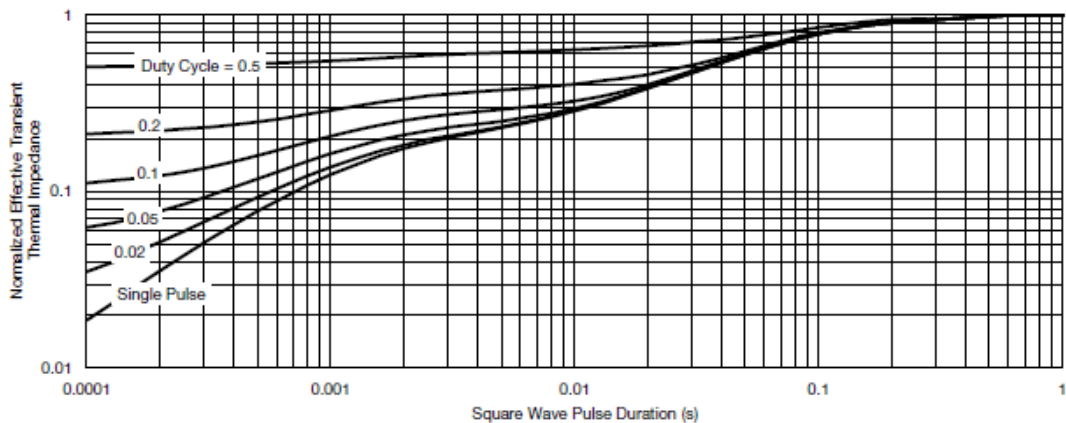

Normalized Thermal Transient Impedance, Junction-to-Case



Typical Characteristics

Gate Charge Test Circuit & Waveform



Resistive Switching Test Circuit & Waveforms



Unclamped Inductive Switching Test Circuit & Waveforms





Package Information (DFN5X6-8L)

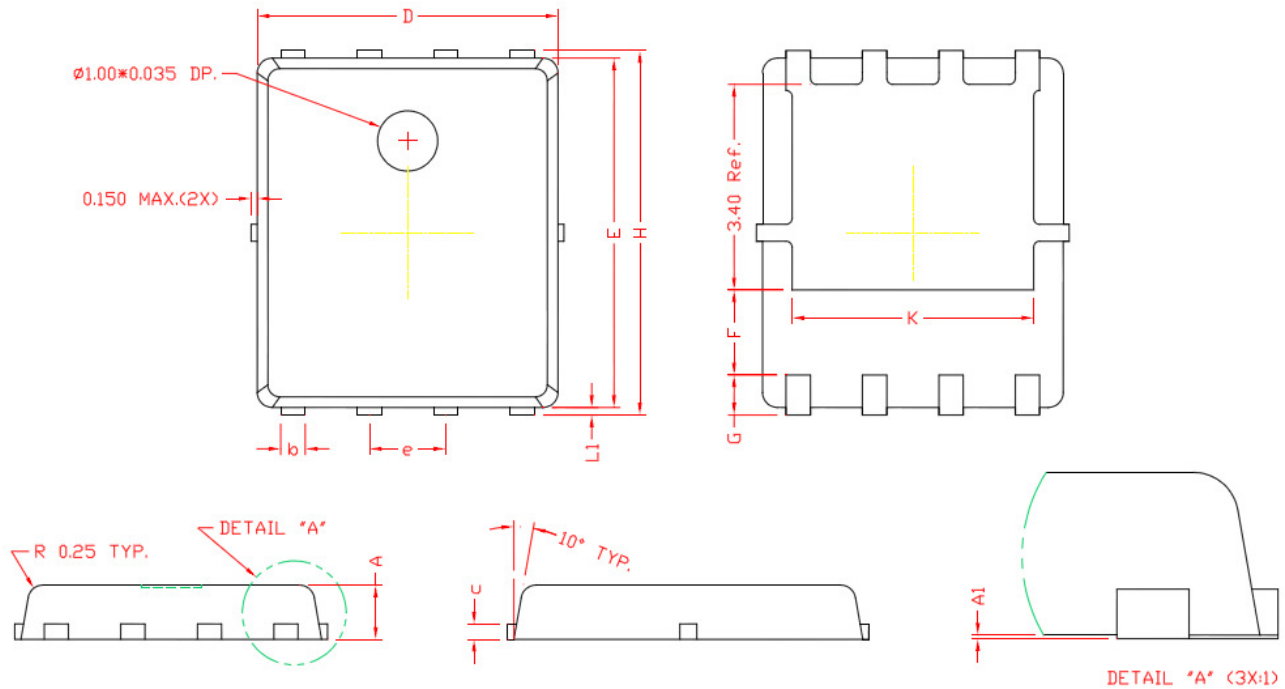

DIMENSIONS

REF.	Millimeters		REF.	Millimeters	
	Min.	Max.		Min.	Max.
A	0.80	1.00	E	5.70	5.90
A1	0.00	0.05	e	1.27 BSC.	
b	0.35	0.49	H	5.95	6.20
c	0.254 Ref.		L1	0.10	0.18
D	4.90	5.10	G	0.60 Ref.	
F	1.40 Ref.		K	4.00 Ref.	

©2010 Alfa-MOS Technology Corp.
 2F, No.80, Sec.1, Cheng Kung Rd., Nan Kang Dist., Taipei City 115, Taiwan (R.O.C.)
 Tel : 886 2) 2651 3928
 Fax : 886 2) 2786 8483
 ©http://www.alfa-mos.com