



General Description

AFN9970S, N-Channel enhancement mode MOSFET, uses Advanced Trench Technology to provide excellent $R_{DS(ON)}$, low gate charge.

These devices are particularly suited for low voltage power management, and low in-line power loss are needed in commercial industrial surface mount applications.

Features

- 60V/20A, $R_{DS(ON)}=10m\Omega@V_{GS}=10V$
- 60V/10A, $R_{DS(ON)}=13m\Omega@V_{GS}=4.5V$
- Super high density cell design for extremely low $R_{DS(ON)}$
- TO-252-2L package design

Pin Description (TO-252-2L)

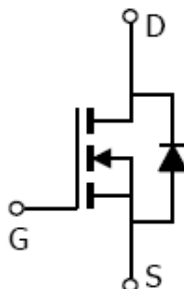
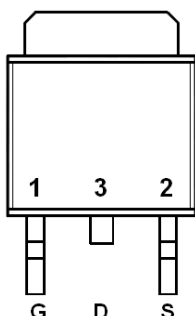

Application

- Motor and Load Control
- Power Management in White LED System
- Push Pull Converter
- LCD TV Inverter & AD/DC Inverter Systems.

Pin Define

Pin	Symbol	Description
1	G	Gate
2	S	Source
3	D	Drain

Ordering Information

Part Ordering No.	Part Marking	Package	Unit	Quantity
AFN9970ST252RG	9970S	TO-252-2L	Tape & Reel	2500 EA

※ A Lot code

※ B Date code

※ AFN9970ST252RG : 13" Tape & Reel ; Pb- Free ; Halogen -Free



※ **Absolute Maximum Ratings**($T_A=25^\circ\text{C}$ Unless otherwise noted)

Parameter	Symbol	Typical	Unit
Drain-Source Voltage	V_{DSS}	60	V
Gate –Source Voltage	V_{GSS}	± 20	V
Continuous Drain Current($T_J=150^\circ\text{C}$)	$T_C=25^\circ\text{C}$	46	A
	$T_C=70^\circ\text{C}$	37	
Pulsed Drain Current ($t=100\mu\text{s}$)	$T_A=25^\circ\text{C}$	18	
	$T_A=70^\circ\text{C}$	15	
Continuous Source Current(Diode Conduction)	I_S	28	mJ
Single Pulse Avalanche Current	I_{AS}	20	
Power Dissipation	E_{AS}	20	W
	P_D	31	
Operating Junction Temperature	T_J	150	$^\circ\text{C}$
	T_{STG}	-55/150	
Storage Temperature Range			$^\circ\text{C}$
Thermal Resistance-Junction to Ambient	$R_{\theta JA}$	23	$^\circ\text{C}/\text{W}$
Maximum Junction-to-Case (Drain)	$R_{\theta JA}$	1.5	

※ **Electrical Characteristics**($T_A=25^\circ\text{C}$ Unless otherwise noted)

Parameter	Symbol	Conditions	Min.	Typ	Max.	Unit
Static						
Drain-Source Breakdown Voltage	$V_{(BR)DSS}$	$V_{GS}=0V, I_D=250\mu\text{A}$	60			V
Gate Threshold Voltage	$V_{GS(th)}$	$V_{DS}=V_{GS}, I_D=250\mu\text{A}$	1.0		2.5	
Gate Leakage Current	I_{GSS}	$V_{DS}=0V, V_{GS}=\pm 20V$			± 100	nA
Zero Gate Voltage Drain Current	I_{DSS}	$V_{DS}=48V, V_{GS}=0V$			1	uA
		$V_{DS}=48V, V_{GS}=0V$ $T_J=85^\circ\text{C}$			10	
On-State Drain Current	$I_{D(on)}$	$V_{DS} \geq 5V, V_{GS}=10V$	30			A
Drain-Source On-Resistance	$R_{DS(on)}$	$V_{GS}=10V, I_D=20A$		8.5	10	m Ω
		$V_{GS}=4.5V, I_D=10A$		11.5	13	
Forward Transconductance	g_{FS}	$V_{DS}=15V, I_D=10A$		80		S
Diode Forward Voltage	V_{SD}	$I_S=5A, V_{GS}=0V$		0.78	1.2	V
Dynamic						
Total Gate Charge	Q_g	$V_{DS}=30V, V_{GS}=4.5V$ $I_D \equiv 10A$		9.2	15	nC
Gate-Source Charge	Q_{gs}			4.2		
Gate-Drain Charge	Q_{gd}			2.5		
Gate Resistance	R_g	$f=1\text{MHz}$	0.4	2.3	4.0	Ω
Input Capacitance	C_{iss}	$V_{DS}=30V, V_{GS}=0V$ $f=1\text{MHz}$		1450		pF
Output Capacitance	C_{oss}			1525		
Reverse Transfer Capacitance	C_{rss}			45		
Turn-On Time	$t_{d(on)}$	$V_{DD}=30V, R_L=3.0\Omega$ $I_D \equiv 10A, V_{GEN}=10V$ $R_G=1\Omega$		10	20	ns
	t_r			10	20	
Turn-Off Time	$t_{d(off)}$			25	50	
	t_f			10	20	



※ Typical Characteristics

※

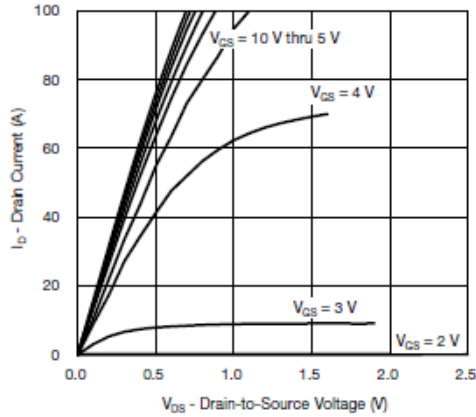

Output Characteristics

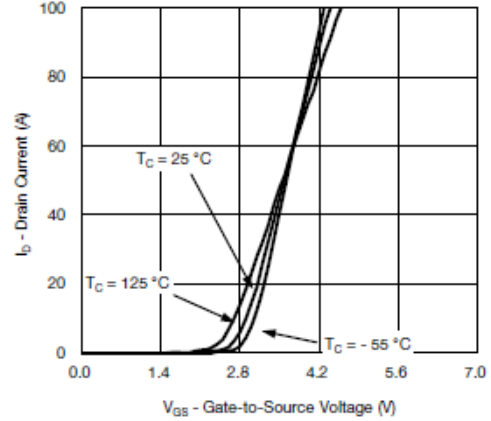

Transfer Characteristics

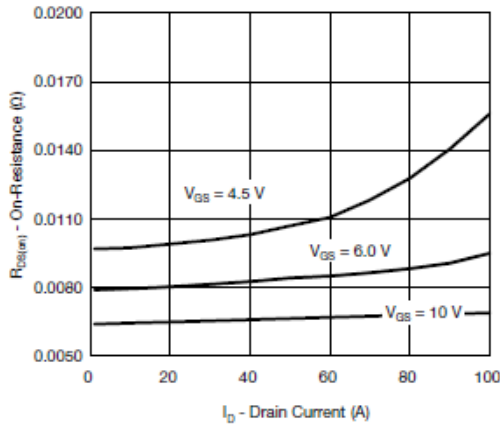

On-Resistance vs. Drain Current

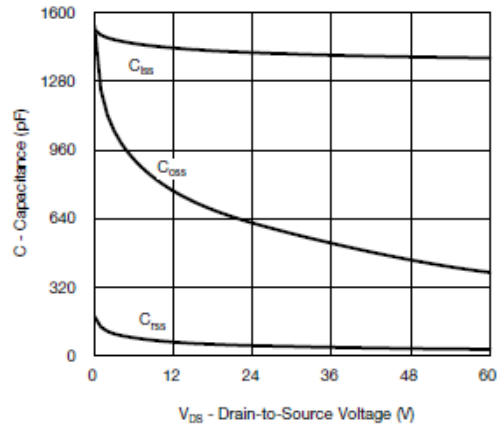

Capacitance

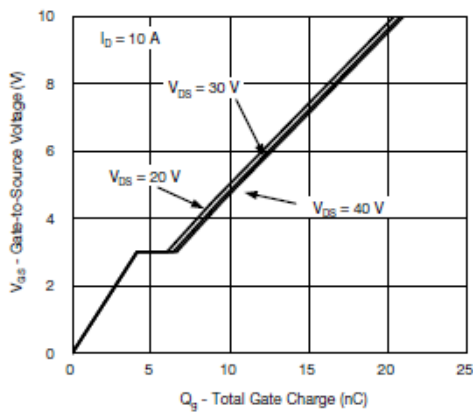

Gate Charge

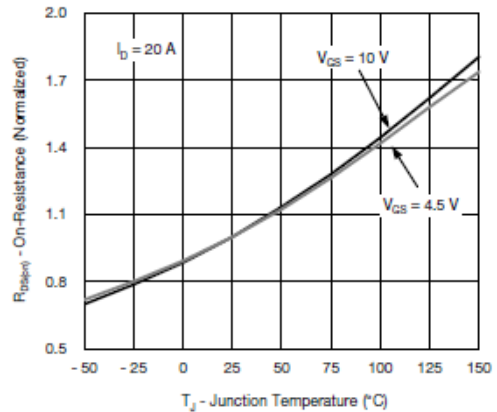

On-Resistance vs. Junction Temperature

※



※ Typical Characteristics

※

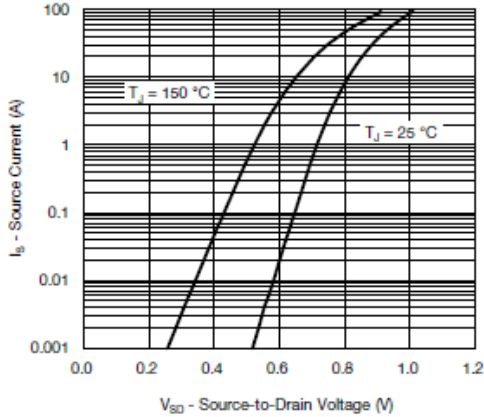

Source-Drain Diode Forward Voltage

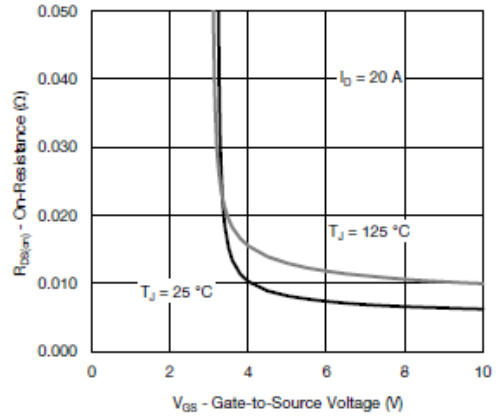

On-Resistance vs. Gate-to-Source Voltage

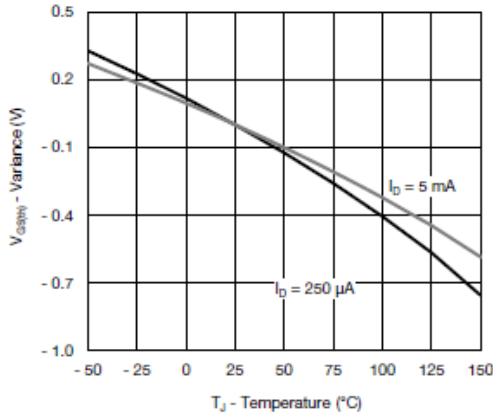

Threshold Voltage

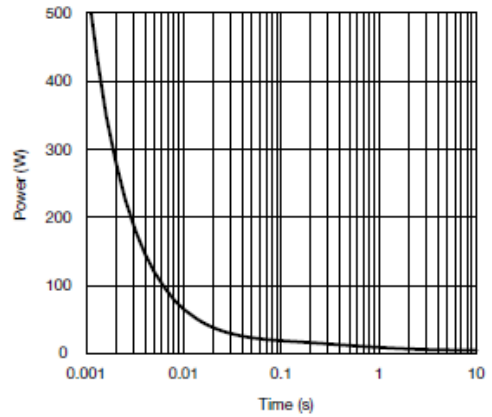

Single Pulse Power, Junction-to-Ambient

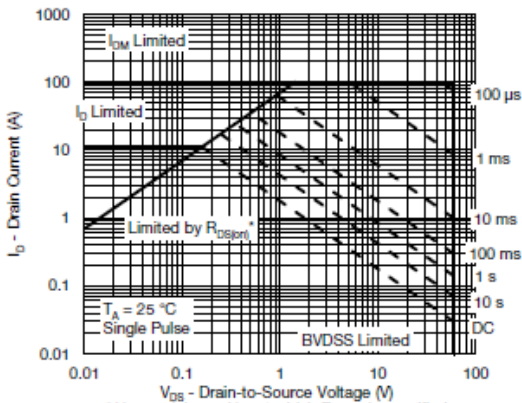

Safe Operating Area, Junction-to-Ambient

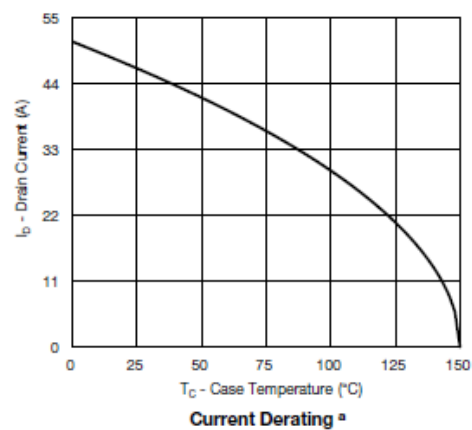

Current Derating *

※



※ Typical Characteristics

※

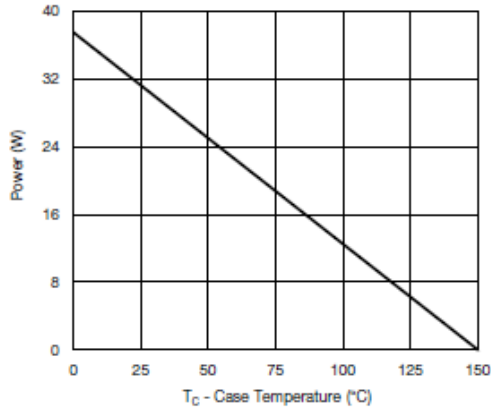

Power, Junction-to-Case

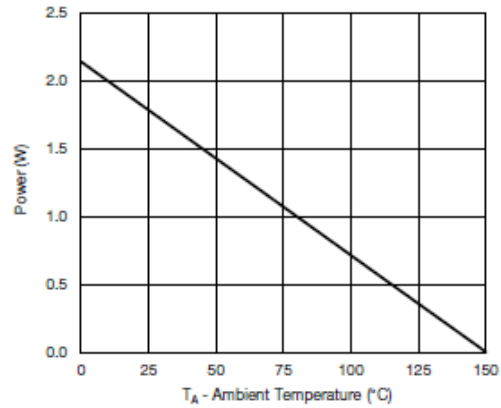

Power, Junction-to-Ambient

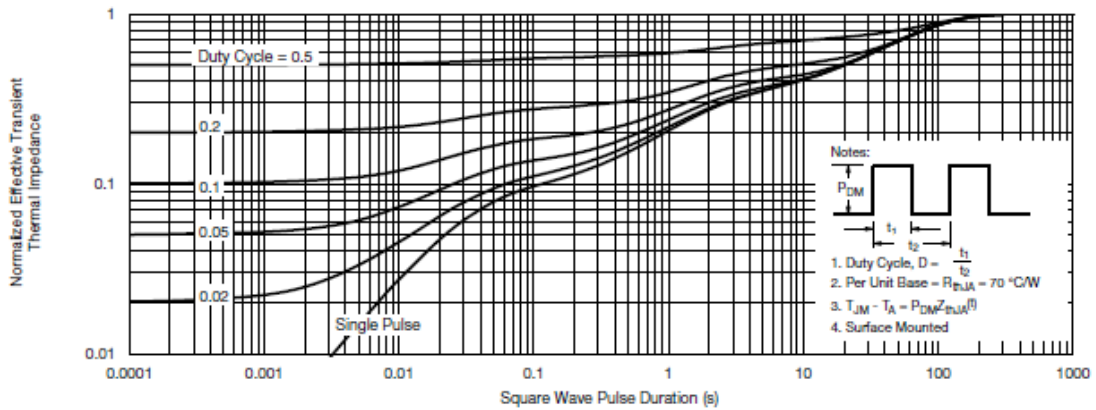

Normalized Thermal Transient Impedance, Junction-to-Ambient

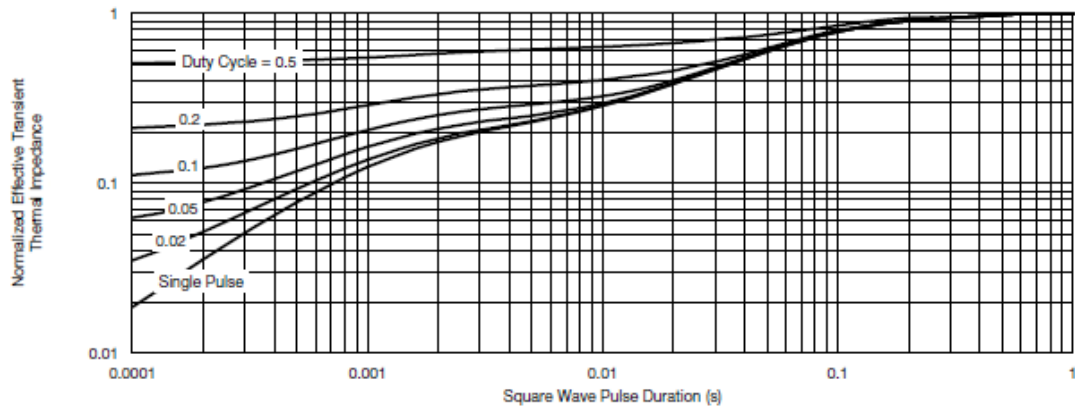

Normalized Thermal Transient Impedance, Junction-to-Case

※



Typical Characteristics

Gate Charge Test Circuit & Waveform

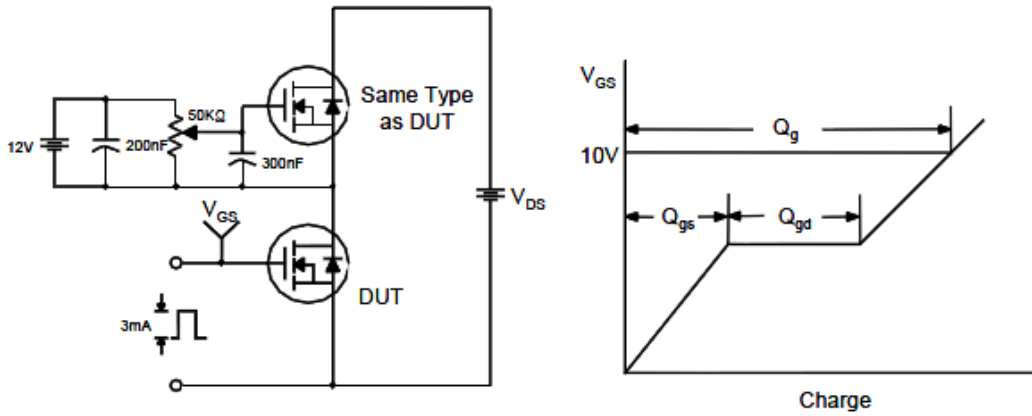

Resistive Switching Test Circuit & Waveforms

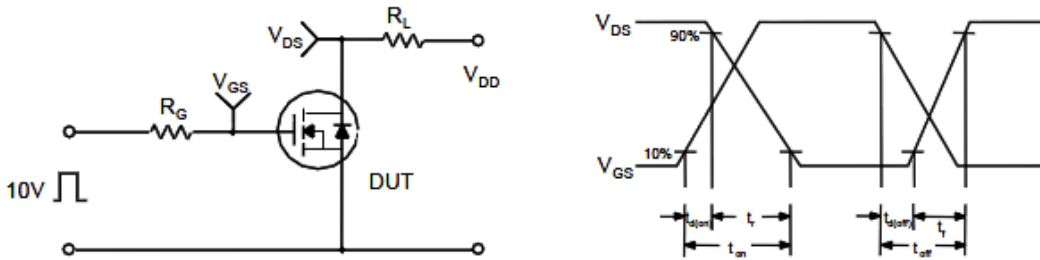

Unclamped Inductive Switching Test Circuit & Waveforms

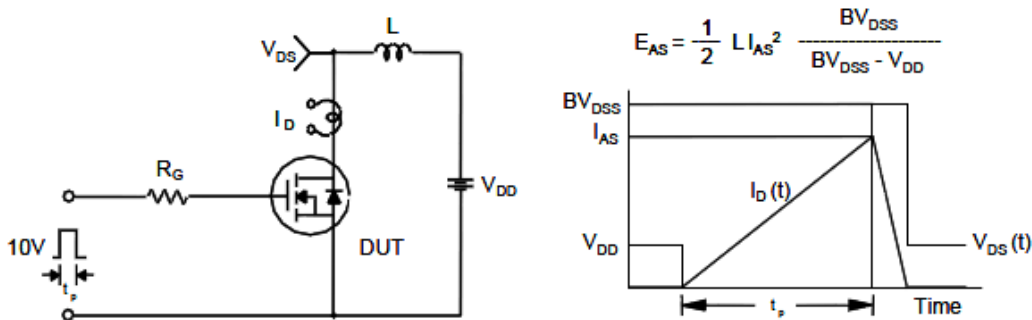



Package Information (TO-252-2L)

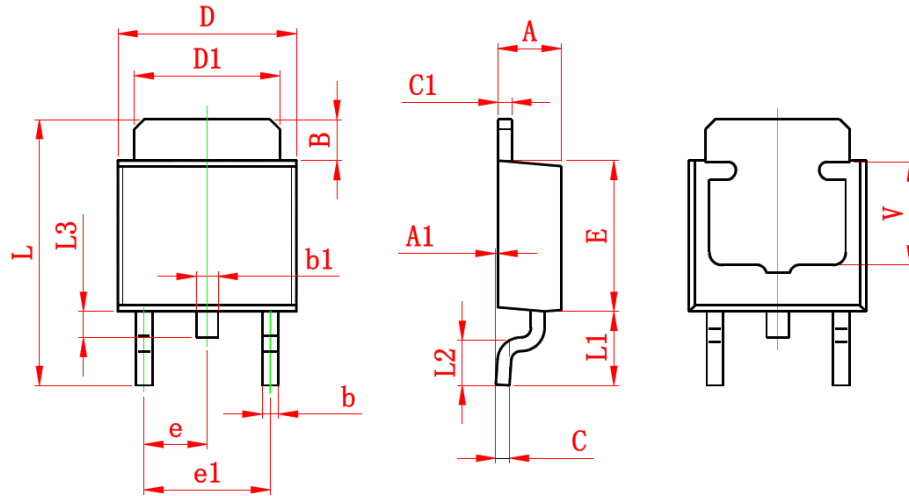

Symbol	Dimensions In Millimeters		Dimensions In Inches	
	Min.	Max.	Min.	Max.
A	2.200	2.400	0.087	0.094
A1	0.000	0.127	0.000	0.005
B	1.350	1.650	0.053	0.065
b	0.500	0.700	0.020	0.028
b1	0.700	0.900	0.028	0.035
c	0.430	0.580	0.017	0.023
c1	0.430	0.580	0.017	0.023
D	6.350	6.650	0.250	0.262
D1	5.200	5.400	0.205	0.213
E	5.400	5.700	0.213	0.224
e	2.300 TYP.		0.091 TYP.	
e1	4.500	4.700	0.177	0.185
L	9.500	9.900	0.374	0.390
L1	2.550	2.900	0.100	0.114
L2	1.400	1.780	0.055	0.070
L3	0.600	0.900	0.024	0.035
V	3.800 REF.		0.150 REF.	

©2010 Alfa-MOS Technology Corp.
 2F, No.80, Sec.1, Cheng Kung Rd., Nan Kang Dist., Taipei City 115, Taiwan (R.O.C.)
 Tel : 886 2) 2651 3928
 Fax : 886 2) 2786 8483
 ©http://www.alfa-mos.com