



General Description

AFP2343A, P-Channel enhancement mode MOSFET, uses Advanced Trench Technology to provide excellent $R_{DS(ON)}$, low gate charge.

These devices are particularly suited for low voltage power management, such as smart phone and notebook computer and other battery powered circuits, and low in-line power loss are needed in commercial industrial surface mount applications.

Features

- $I_D = -2.8A, R_{DS(ON)} = 70m\Omega @ V_{GS} = -4.5V$
- $I_D = -2.4A, R_{DS(ON)} = 92m\Omega @ V_{GS} = -2.5V$
- $I_D = -2.0A, R_{DS(ON)} = 180m\Omega @ V_{GS} = -1.8V$
- Super high density cell design for extremely low RDS (ON)
- Exceptional on-resistance and maximum DC current capability

Pin Description (SOT-23)

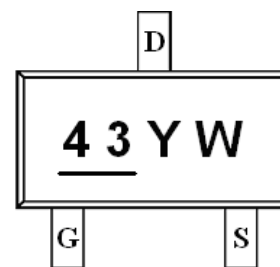
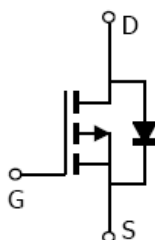
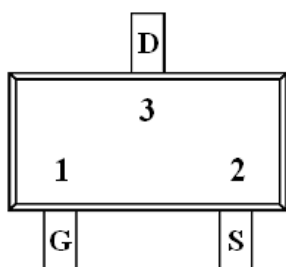

Application

- Portable Equipment
- Battery Powered System
- Net Working System

Pin Define

Pin	Symbol	Description
1	G	Gate
2	S	Source
3	D	Drain

Ordering Information

Part Ordering No.	Part Marking	Package	Unit	Quantity
AFP2343AS23RG	43YW	SOT-23	Tape & Reel	3000 EA

※ 43 parts code

※ Y year code (0 ~ 9)

※ W week code (A ~ Z = 1 ~ 26 / a ~ z = 27 ~ 52)

AFP2343AS23RG : 7" Tape & Reel ; Pb- Free ; Halogen -Free



Absolute Maximum Ratings

(T_A=25°C Unless otherwise noted)

Parameter	Symbol	Value	Unit
Drain-Source Voltage	V _{DSS}	-20	V
Gate –Source Voltage	V _{GSS}	±12	V
Continuous Drain Current(T _J =150°C)	I _D	T _A =25°C	-2.8
		T _A =70°C	-2.4
Pulsed Drain Current	I _{DM}	-10	A
Continuous Source Current(Diode Conduction)	I _S	-1.6	A
Power Dissipation	P _D	T _A =25°C	1.25
		T _A =70°C	0.8
Operating Junction Temperature	T _J	150	°C
Storage Temperature Range	T _{STG}	-55/150	°C
Thermal Resistance-Junction to Ambient	R _{θJA}	120	°C/W

Electrical Characteristics

(T_A=25°C Unless otherwise noted)

Parameter	Symbol	Conditions	Min.	Typ	Max.	Unit
Static						
Drain-Source Breakdown Voltage	V _{(BR)DSS}	V _{GS} =0V, I _D =-250uA	-20			V
Gate Threshold Voltage	V _{GS(th)}	V _{DS} =V _{GS} , I _D =-250uA	-0.4		-1.0	
Gate Leakage Current	I _{GSS}	V _{DS} =0V, V _{GS} =±12V			±100	nA
Zero Gate Voltage Drain Current	I _{DSS}	V _{DS} =-16V, V _{GS} =0V			-1	uA
		V _{DS} =-16V, V _{GS} =0V T _J =85°C			-10	
On-State Drain Current	I _{D(on)}	V _{DS} ≥ -5V, V _{GS} =-4.5V	-6			A
		V _{DS} ≥ -5V, V _{GS} =-2.5V	-4			
Drain-Source On-Resistance	R _{DS(on)}	V _{GS} =-4.5V, I _D =-2.8A		63	70	mΩ
		V _{GS} =-2.5V, I _D =-2.4A		84	92	
		V _{GS} =-1.8V, I _D =-2.0A		165	180	
Forward Transconductance	g _{FS}	V _{DS} =-5V, I _D =-3.6A		10		S
Diode Forward Voltage	V _{SD}	I _S =-1.6A, V _{GS} =0V		-0.85	-1.2	V
Dynamic						
Total Gate Charge	Q _g	V _{DS} =-10V, V _{GS} =-4.5V I _D ≡-4.0A		8.0	12	nC
Gate-Source Charge	Q _{gs}			0.9		
Gate-Drain Charge	Q _{gd}			3.0		
Input Capacitance	C _{iss}	V _{DS} =-10V, V _{GS} =0V f=1MHz		780		pF
Output Capacitance	C _{oss}			115		
Reverse Transfer Capacitance	C _{rss}			55		
Turn-On Time	t _{d(on)}	V _{DD} =-10V, R _L =2.3Ω I _D ≡-4.0A, V _{GEN} =-4.5V R _G =1Ω		0.2	0.3	us
	t _r			1.0	1.5	
Turn-Off Time	t _{d(off)}			4.0	6.0	
	t _f			2.0	3.0	



Typical Characteristics

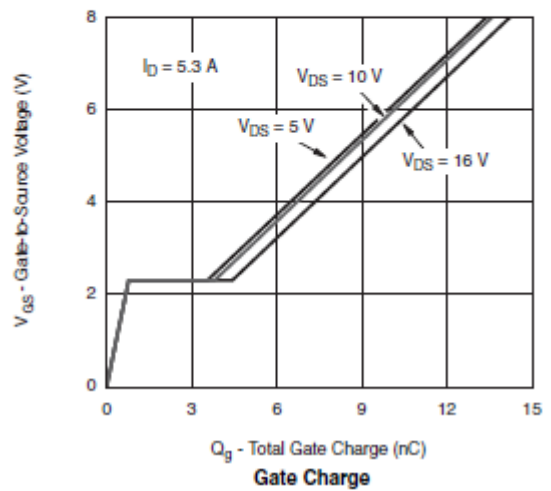
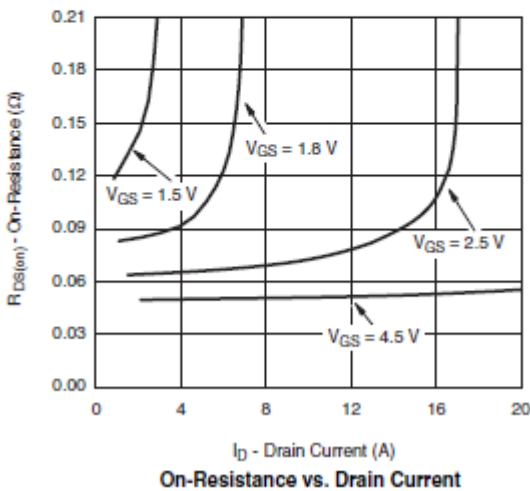
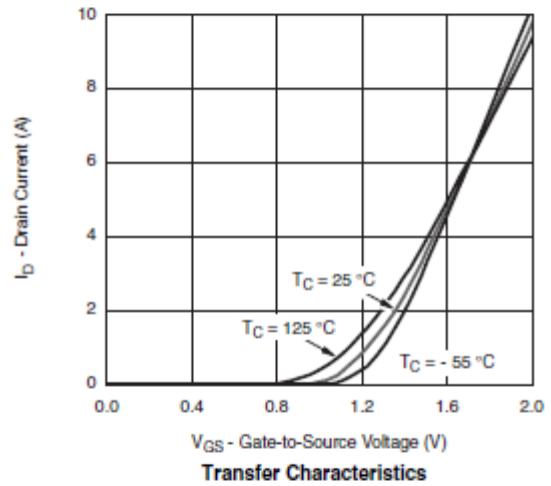
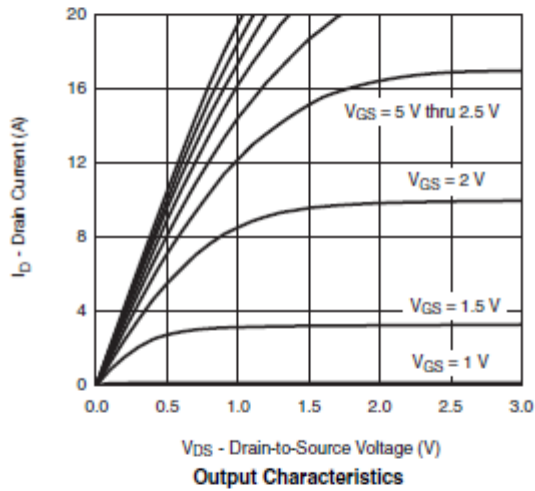
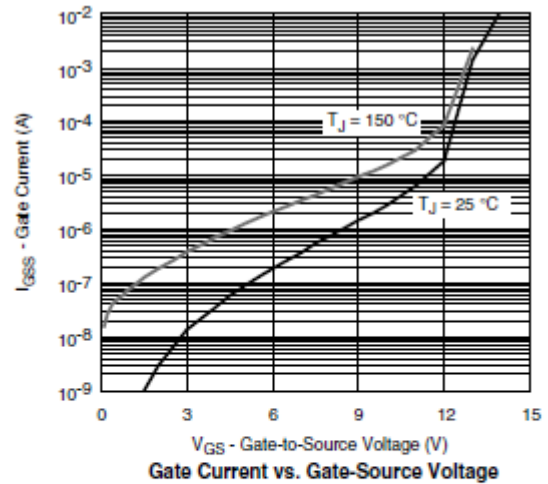
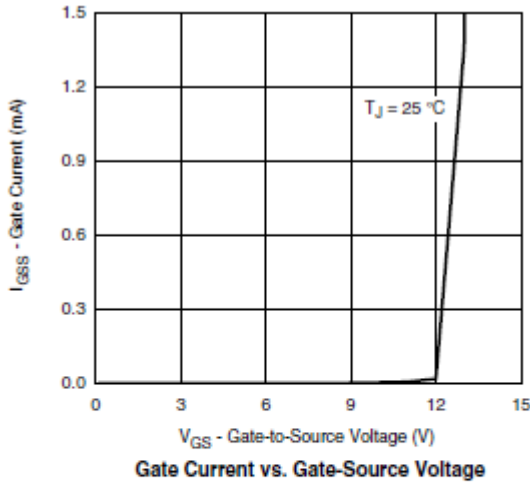



Typical Characteristics

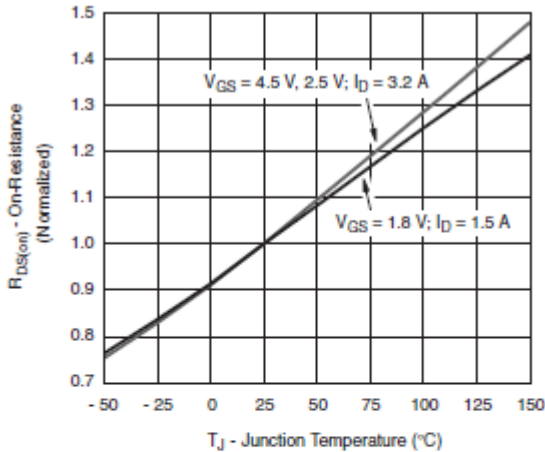

On-Resistance vs. Junction Temperature

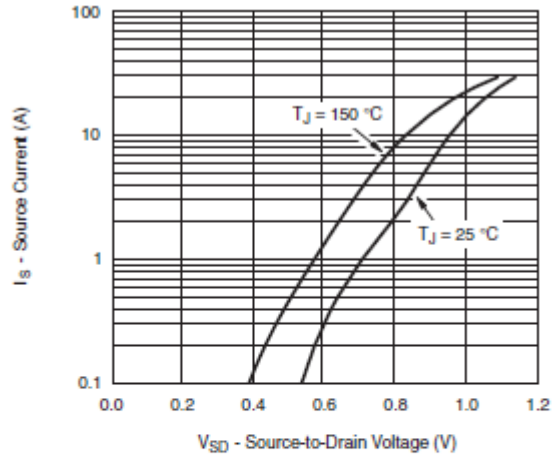

Source-Drain Diode Forward Voltage

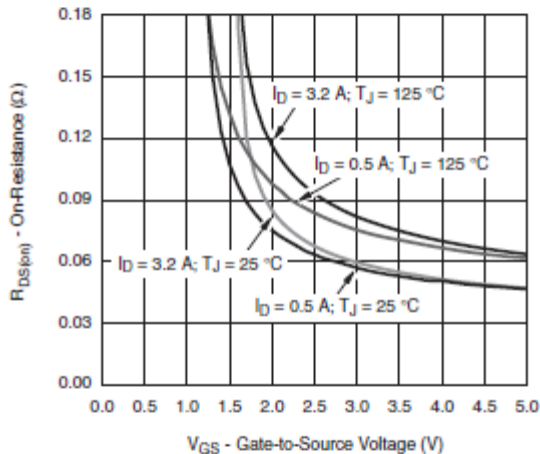

On-Resistance vs. Gate-to-Source Voltage

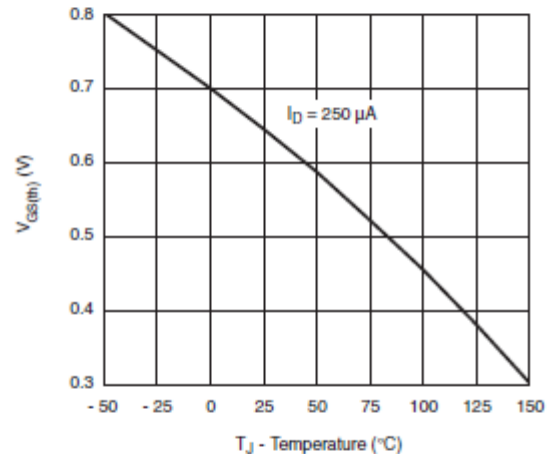

Threshold Voltage

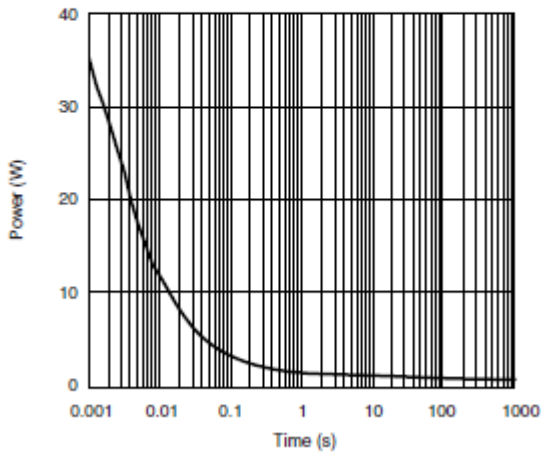

Single Pulse Power, Junction-to-Ambient

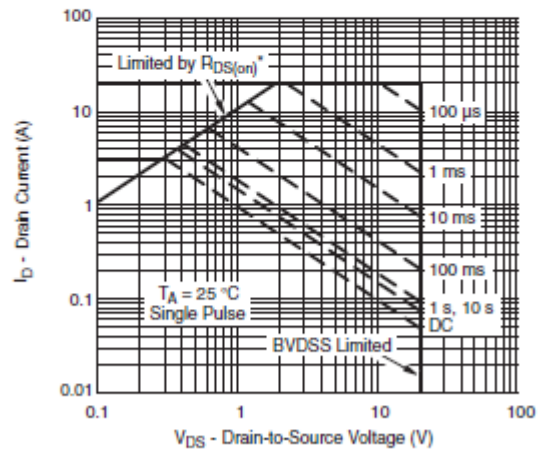

Safe Operating Area, Junction-to-Ambient



Typical Characteristics

Gate Charge Test Circuit & Waveform

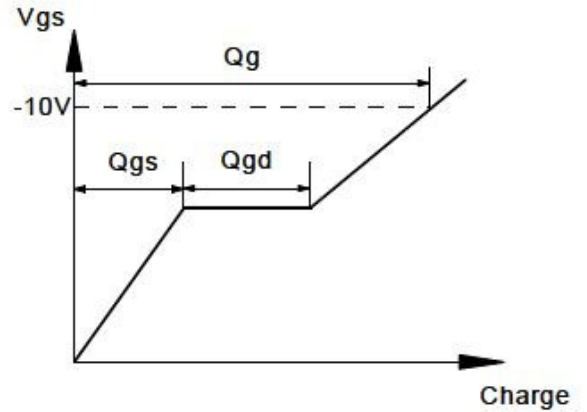
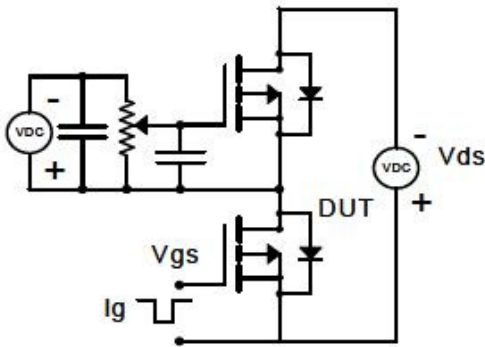

Resistive Switching Test Circuit & Waveforms

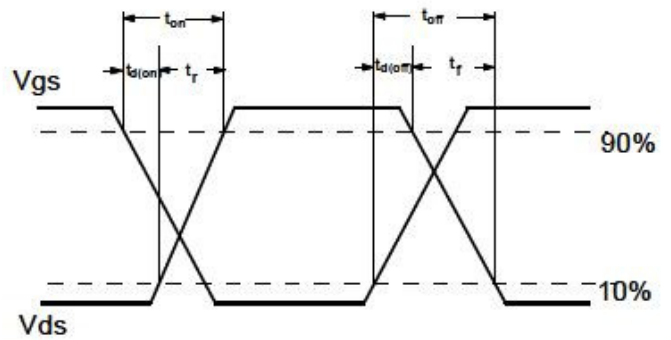
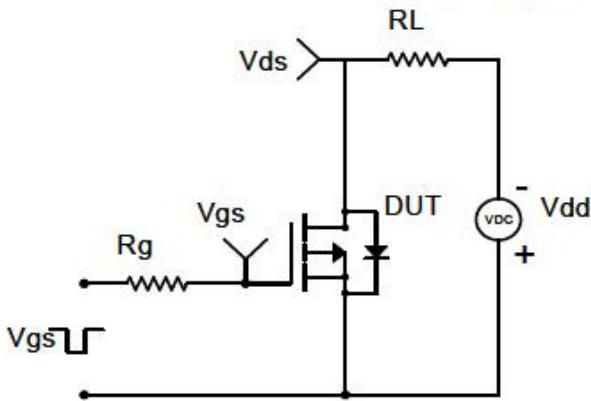

Diode Recovery Test Circuit & Waveforms

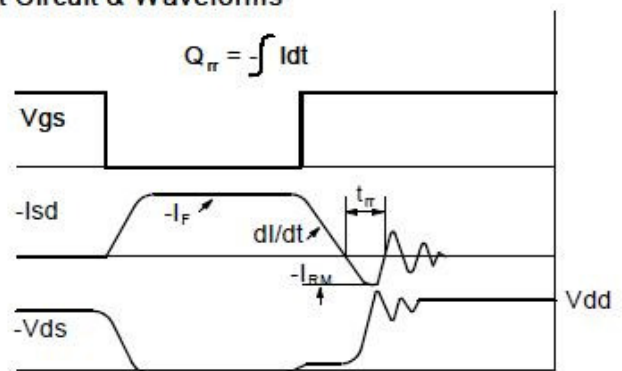
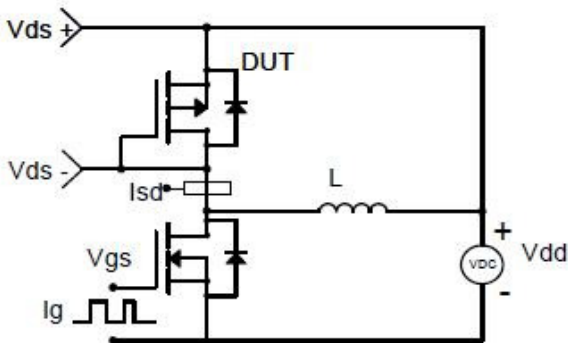



Package Information (SOT-23)

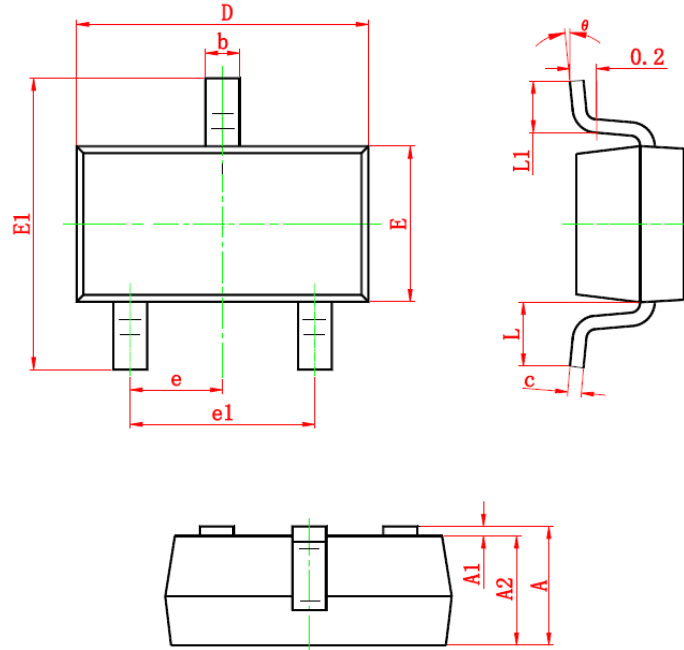

Symbol	Dimensions In Millimeters		Dimensions In Inches	
	Min	Max	Min	Max
A	0.900	1.200	0.035	0.043
A1	0.000	0.100	0.000	0.004
A2	0.900	1.100	0.035	0.039
b	0.300	0.500	0.012	0.020
c	0.080	0.150	0.003	0.006
D	2.800	3.000	0.110	0.118
E	1.200	1.400	0.047	0.055
E1	2.250	2.550	0.089	0.100
e	0.950 TYP		0.037 TYP	
e1	1.800	2.000	0.071	0.079
L	0.550 REF		0.022 REF	
L1	0.300	0.500	0.012	0.020
θ	0°	8°	0°	6°

©2010 Alfa-MOS Technology Corp.
 2F, No.80, Sec.1, Cheng Kung Rd., Nan Kang Dist., Taipei City 115, Taiwan (R.O.C.)
 Tel : 886 2) 2651 3928
 Fax : 886 2) 2786 8483
 ©http://www.alfa-mos.com