



General Description

AFP2421WS, P-Channel enhancement mode MOSFET, uses Advanced Trench Technology to provide excellent $R_{DS(ON)}$, low gate charge.

These devices are particularly suited for low voltage power management, such as smart phone and notebook computer and other battery powered circuits, and low in-line power loss are needed in commercial industrial surface mount applications.

Features

- $I_D = -5.3A, R_{DS(ON)} = 30m\Omega @ V_{GS} = -10V$
- $I_D = -4.2A, R_{DS(ON)} = 40m\Omega @ V_{GS} = -4.5V$
- Super high density cell design for extremely low $R_{DS(ON)}$
- Exceptional on-resistance and maximum DC current capability
- DFN2X2-6L package design

Pin Description (DFN2X2-6L)

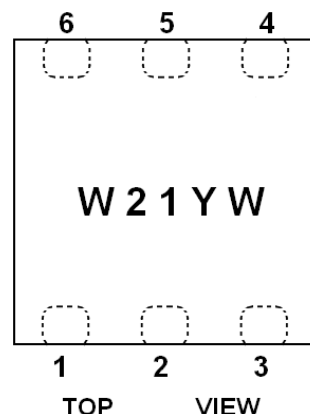
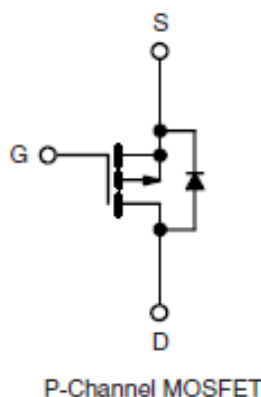
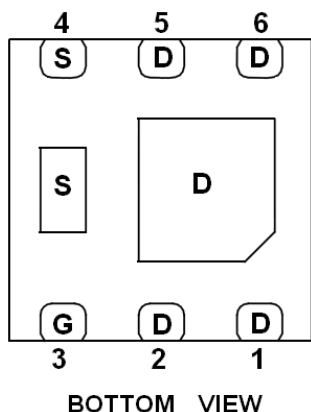

Application

- Load Switch, PA Switch and Battery Switch for Portable Devices

Pin Define

Pin	Symbol	Description
1,2,5,6	D	Drain
4	S	Source
3	G	Gate

Ordering Information

Part Ordering No.	Part Marking	Package	Unit	Quantity
AFP2421WSFN226RG	W21YW	DFN2X2-6L	Tape & Reel	4000 EA

※ W21 parts code

※ Y year code

※ W week code (A ~ Z = 1 ~ 26 / a ~ z = 27 ~ 52)

※ AFP2421WSFN226RG : 7" Tape & Reel ; Pb- Free ; Halogen- Free



Absolute Maximum Ratings

(T_A=25°C Unless otherwise noted)

Parameter	Symbol	Value	Unit
Drain-Source Voltage	V _{DSS}	-30	V
Gate -Source Voltage	V _{GSS}	±20	V
Continuous Drain Current(T _J =150°C)	I _D	T _A =25°C	-7.9
		T _A =70°C	-6.3
Pulsed Drain Current	I _{DM}	-35	A
Continuous Source Current(Diode Conduction)	I _S	-2.9	A
Power Dissipation	P _D	T _A =25°C	3.5
		T _A =70°C	2.2
Operating Junction Temperature	T _J	150	°C
Storage Temperature Range	T _{STG}	-55/150	°C
Thermal Resistance-Junction to Ambient	R _{θJA}	36	°C/W

Electrical Characteristics

(T_A=25°C Unless otherwise noted)

Parameter	Symbol	Conditions	Min.	Typ	Max.	Unit
Static						
Drain-Source Breakdown Voltage	V _{(BR)DSS}	V _{GS} =0V, I _D =-250uA	-30			V
Gate Threshold Voltage	V _{GS(th)}	V _{DS} =V _{GS} , I _D =-250uA	-1.0		-2.0	
Gate Leakage Current	I _{GSS}	V _{DS} =0V, V _{GS} =±20V			±100	nA
Zero Gate Voltage Drain Current	I _{DSS}	V _{DS} =-24V, V _{GS} =0V			-1	uA
		V _{DS} =-24V, V _{GS} =0V T _J =85°C			-30	
On-State Drain Current	I _{D(on)}	V _{DS} ≤ -5V, V _{GS} =-10V	-20			A
Drain-Source On-Resistance	R _{DS(on)}	V _{GS} =-10V, I _D =-5.3A		22	30	mΩ
		V _{GS} =-4.5V, I _D =-4.2A		28	40	
Forward Transconductance	g _{FS}	V _{DS} =-15V, I _D =-5.3A		15		S
Diode Forward Voltage	V _{SD}	I _S =-2.0A, V _{GS} =0V		-0.75	-1.3	V
Dynamic						
Total Gate Charge	Q _g	V _{DS} =-10V, V _{GS} =-4.5V I _D ≡-7.9A		10	15	nC
Gate-Source Charge	Q _{gs}			3		
Gate-Drain Charge	Q _{gd}			4.5		
Input Capacitance	C _{iss}	V _{DS} =-15V, V _{GS} =0V f=1MHz		950		pF
Output Capacitance	C _{oss}			150		
Reverse Transfer Capacitance	C _{rss}			120		
Turn-On Time	t _{d(on)}	V _{DD} =-15V, R _L =2.4Ω I _D ≡-6.3A, V _{GEN} =-10V R _G =1Ω		10	20	ns
	t _r			12	25	
Turn-Off Time	t _{d(off)}			30	55	
	t _f			10	20	



Typical Characteristics

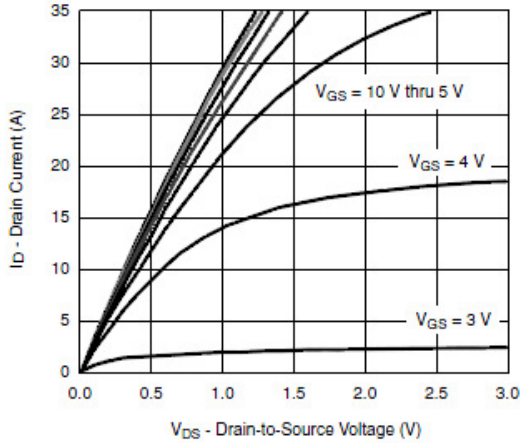

Output Characteristics

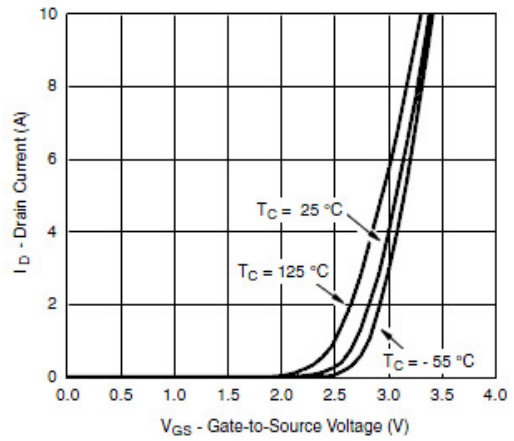

Transfer Characteristics

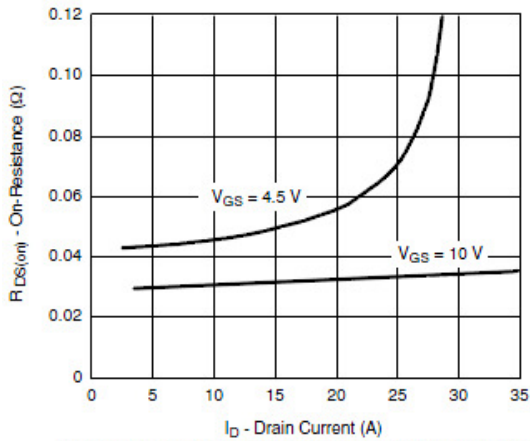

On-Resistance vs. Drain Current and Gate Voltage

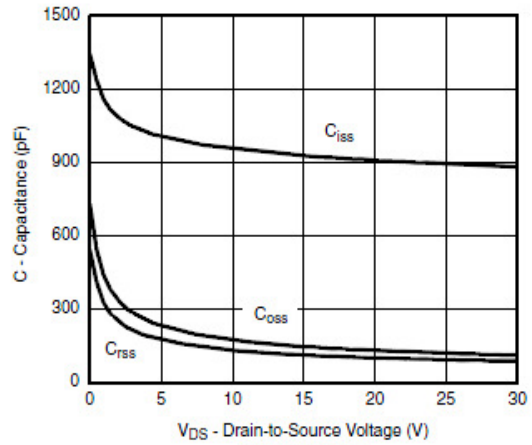

Capacitance

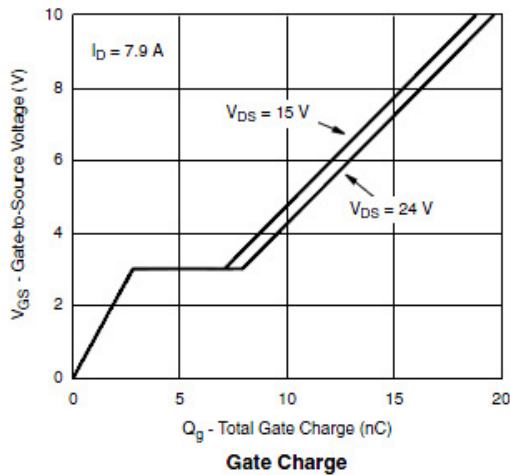

Gate Charge

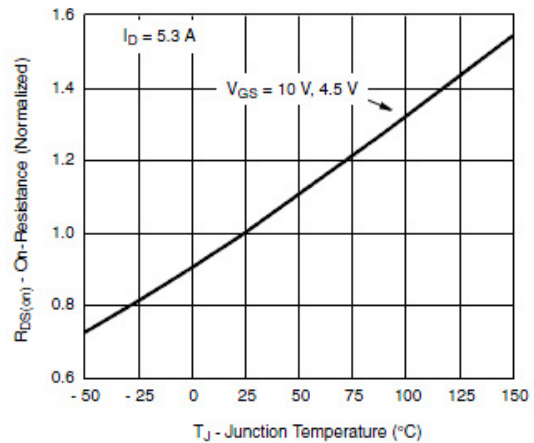

On-Resistance vs. Junction Temperature



Typical Characteristics

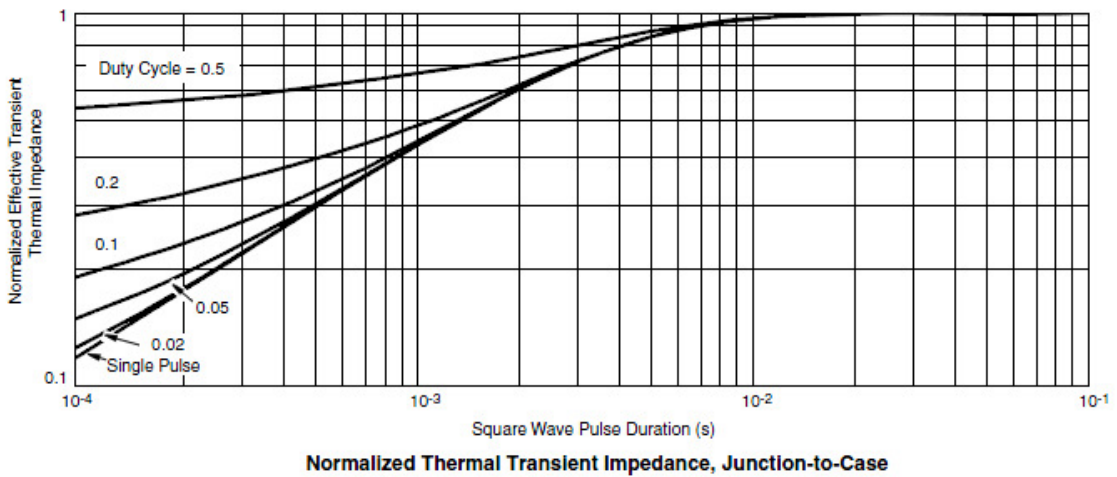
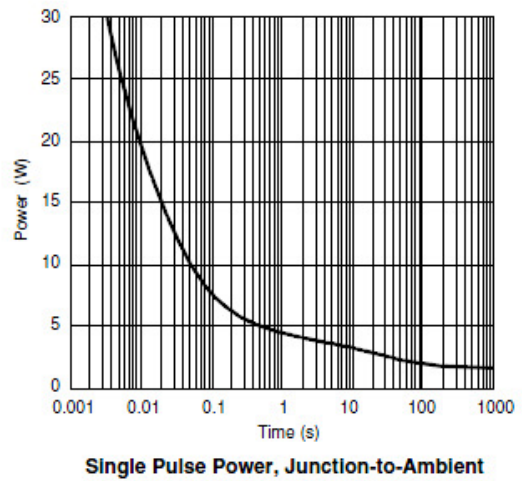
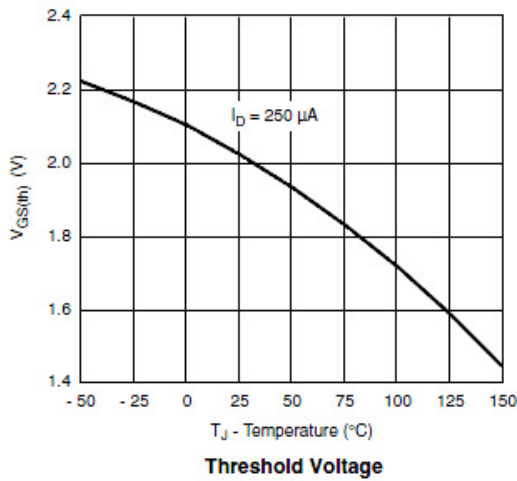
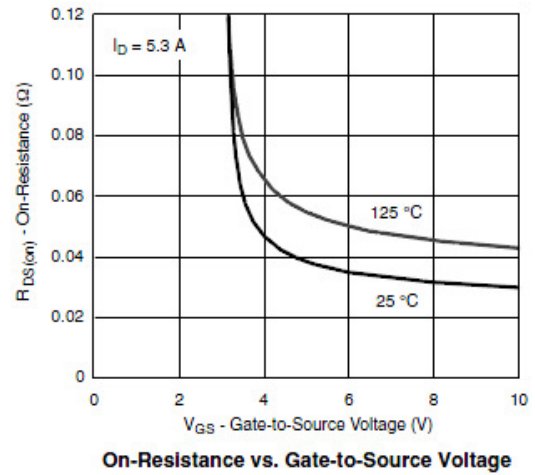
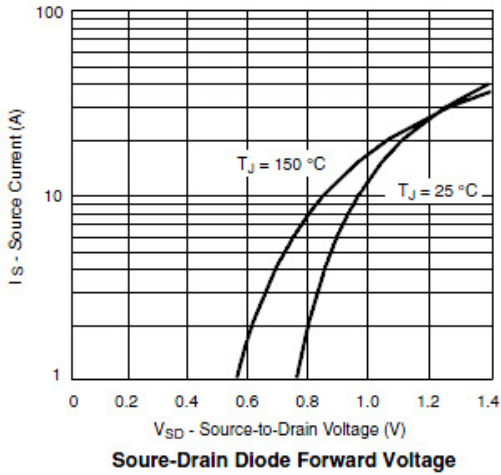



Typical Characteristics

Gate Charge Test Circuit & Waveform

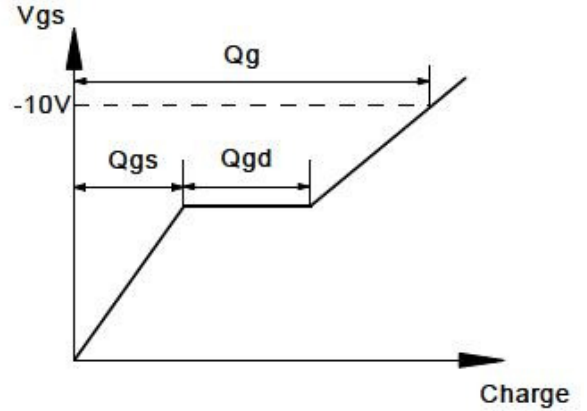
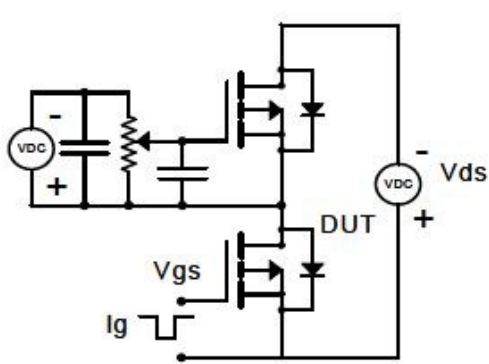

Resistive Switching Test Circuit & Waveforms

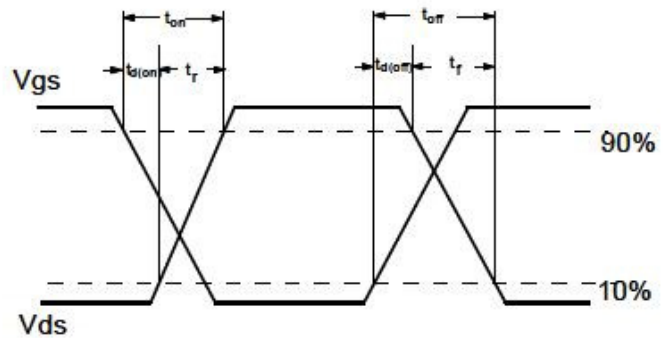
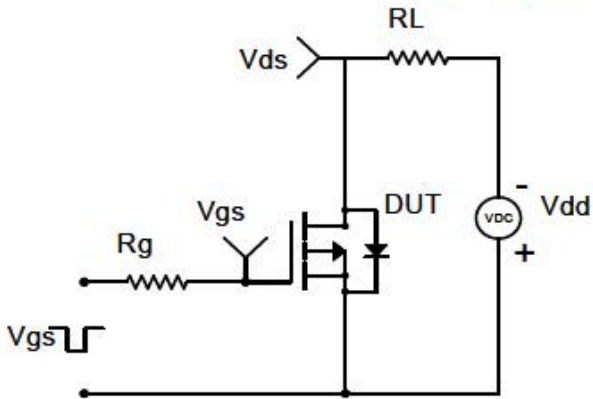

Diode Recovery Test Circuit & Waveforms

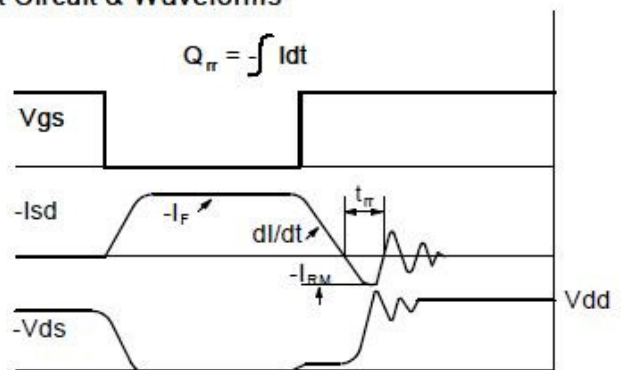
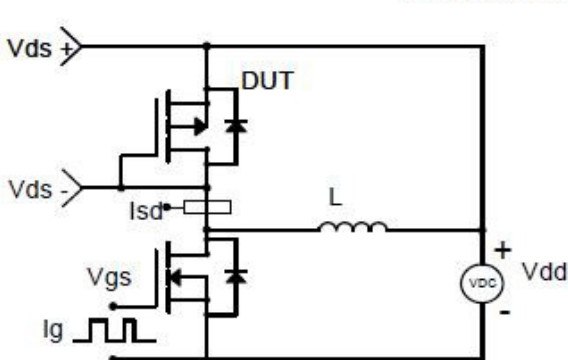



Package Information (DFN2X2-6L)

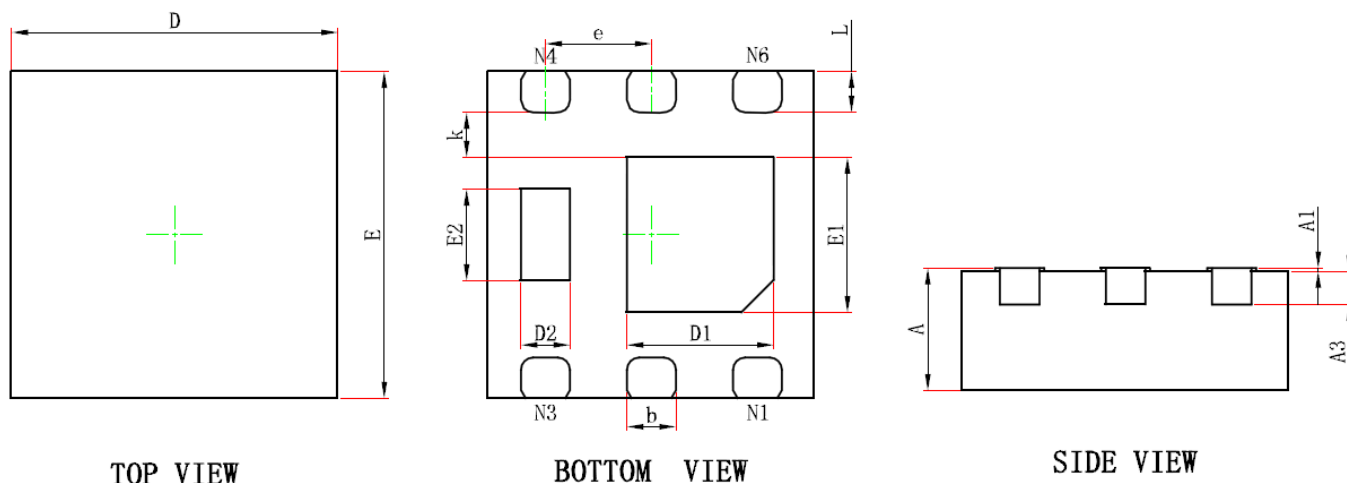

Symbol	Dimensions In Millimeters		Dimensions In Inches	
	Min.	Max.	Min.	Max.
A	0.700	0.800	0.028	0.031
A1	0.000	0.050	0.000	0.002
A3	0.203REF.		0.008REF.	
D	1.924	2.076	0.076	0.082
E	1.924	2.076	0.076	0.082
D1	0.800	1.000	0.031	0.039
E1	0.850	1.050	0.033	0.041
D2	0.200	0.400	0.008	0.016
E2	0.460	0.660	0.018	0.026
k	0.200MIN.		0.008MIN.	
b	0.250	0.350	0.010	0.014
e	0.650TYP.		0.026TYP.	
L	0.174	0.326	0.007	0.013

©2010 Alfa-MOS Technology Corp.
 2F, No.80, Sec.1, Cheng Kung Rd., Nan Kang Dist., Taipei City 115, Taiwan (R.O.C.)
 Tel : 886 2) 2651 3928
 Fax : 886 2) 2786 8483
 ©http://www.alfa-mos.com