



### General Description

AFP3413, P-Channel enhancement mode MOSFET, uses Advanced Trench Technology to provide excellent  $R_{DS(ON)}$ , low gate charge.

These devices are particularly suited for low voltage power management, such as smart phone and notebook computer and other battery powered circuits, and low in-line power loss are needed in commercial industrial surface mount applications.

### Features

- -20V/-3.2A,  $R_{DS(ON)}=95m\Omega@V_{GS}=-4.5V$
- -20V/-2.6A,  $R_{DS(ON)}=125m\Omega@V_{GS}=-2.5V$
- -20V/-1.5A,  $R_{DS(ON)}=205m\Omega@V_{GS}=-1.8V$
- Super high density cell design for extremely low  $R_{DS(ON)}$
- Exceptional on-resistance and maximum DC current capability
- SOT-23-3L package design

### Pin Description ( SOT-23-3L )

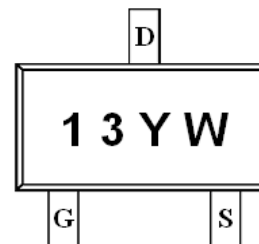
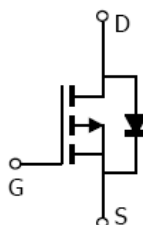
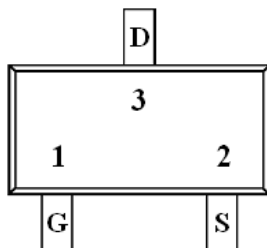

### Application

- Power Management in Note book
- Portable Equipment
- Battery Powered System
- Net Working System

### Pin Define

Pin	Symbol	Description
1	G	Gate
2	S	Source
3	D	Drain

### Ordering Information

Part Ordering No.	Part Marking	Package	Unit	Quantity
AFP3413S23RG	13YW	SOT-23-3L	Tape & Reel	3000 EA

- ※ 13 parts code
- ※ Y year code ( 0 ~ 9 )
- ※ W week code ( A ~ Z = 1 ~ 26 / a ~ z = 27 ~ 52 )
- ※ AFP3413S23RG : 7" Tape & Reel ; Pb- Free ; Halogen -Free



### Absolute Maximum Ratings

( $T_A=25^\circ\text{C}$  Unless otherwise noted)

Parameter	Symbol	Value	Unit
Drain-Source Voltage	$V_{DSS}$	-20	V
Gate-Source Voltage	$V_{GSS}$	$\pm 12$	V
Continuous Drain Current( $T_J=150^\circ\text{C}$ )	$I_D$	$T_A=25^\circ\text{C}$	-3.2
		$T_A=70^\circ\text{C}$	-2.6
Pulsed Drain Current	$I_{DM}$	-10	A
Continuous Source Current(Diode Conduction)	$I_S$	-1.6	A
Power Dissipation	$P_D$	$T_A=25^\circ\text{C}$	1.25
		$T_A=70^\circ\text{C}$	0.8
Operating Junction Temperature	$T_J$	150	$^\circ\text{C}$
Storage Temperature Range	$T_{STG}$	-55/150	$^\circ\text{C}$
Thermal Resistance-Junction to Ambient	$R_{\theta JA}$	120	$^\circ\text{C/W}$

### Electrical Characteristics

( $T_A=25^\circ\text{C}$  Unless otherwise noted)

Parameter	Symbol	Conditions	Min.	Typ	Max.	Unit
<b>Static</b>						
Drain-Source Breakdown Voltage	$V_{(BR)DSS}$	$V_{GS}=0V, I_D=-250\mu\text{A}$	-20			V
Gate Threshold Voltage	$V_{GS(th)}$	$V_{DS}=V_{GS}, I_D=-250\mu\text{A}$	-0.35		-1.0	
Gate Leakage Current	$I_{GSS}$	$V_{DS}=0V, V_{GS}=\pm 12V$			$\pm 100$	nA
Zero Gate Voltage Drain Current	$I_{DSS}$	$V_{DS}=-16V, V_{GS}=0V$			-1	$\mu\text{A}$
		$V_{DS}=-16V, V_{GS}=0V$ $T_J=85^\circ\text{C}$			-30	
On-State Drain Current	$I_{D(on)}$	$V_{DS} \leq -5V, V_{GS}=-4.5V$	-6			A
		$V_{DS} \leq -5V, V_{GS}=-2.5V$	-3			
Drain-Source On-Resistance	$R_{DS(on)}$	$V_{GS}=-4.5V, I_D=-3.2A$		78	95	m $\Omega$
		$V_{GS}=-2.5V, I_D=-2.6A$		114	125	
		$V_{GS}=-1.8V, I_D=-1.5A$		180	205	
Forward Transconductance	$g_{FS}$	$V_{DS}=-5V, I_D=-2.8A$		6.5		S
Diode Forward Voltage	$V_{SD}$	$I_S=-1.25A, V_{GS}=0V$		-0.75	-1.3	V
<b>Dynamic</b>						
Total Gate Charge	$Q_g$	$V_{DS}=-6V, V_{GS}=-4.5V$ $I_D \equiv -2.8A$		5.8	10	nC
Gate-Source Charge	$Q_{gs}$			0.85		
Gate-Drain Charge	$Q_{gd}$			1.7		
Input Capacitance	$C_{iss}$	$V_{DS}=-6V, V_{GS}=0V$ $f=1\text{MHz}$		415		pF
Output Capacitance	$C_{oss}$			223		
Reverse Transfer Capacitance	$C_{rss}$			87		
Turn-On Time	$t_{d(on)}$	$V_{DD}=-6V, R_L=6\Omega$ $I_D \equiv -1.0A, V_{GEN}=-4.5V$ $R_G=6\Omega$		13	25	ns
	$t_r$			36	60	
Turn-Off Time	$t_{d(off)}$			42	70	
	$t_f$			34	60	



## Typical Characteristics

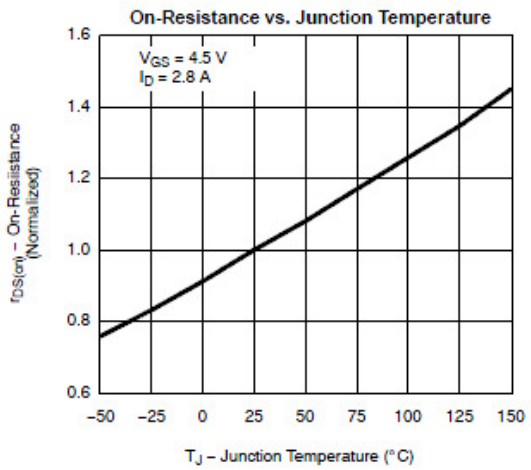
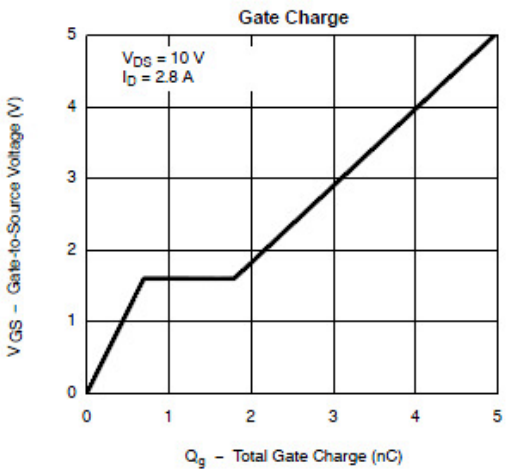
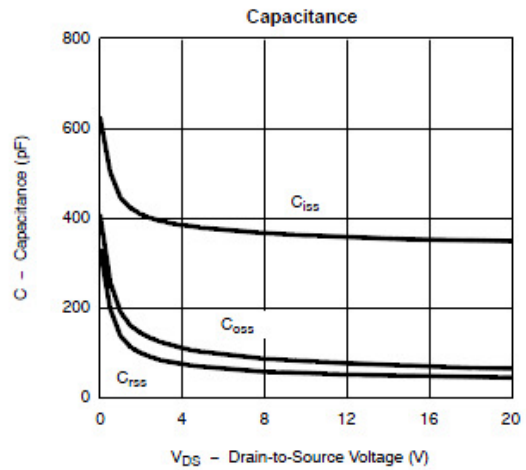
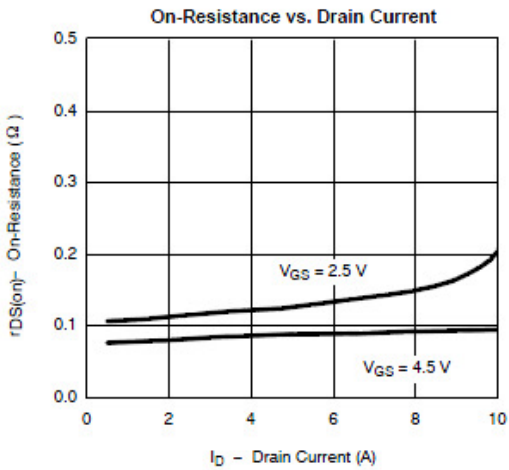
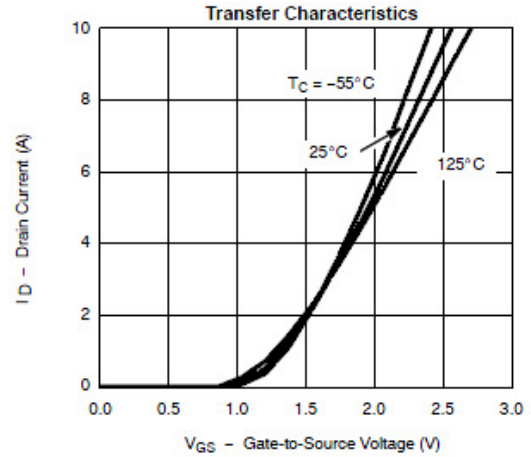
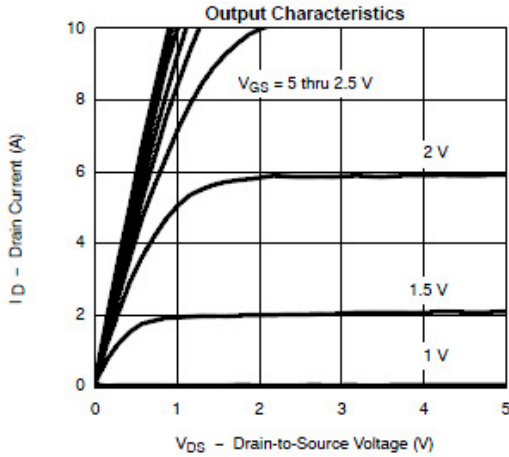



## Typical Characteristics

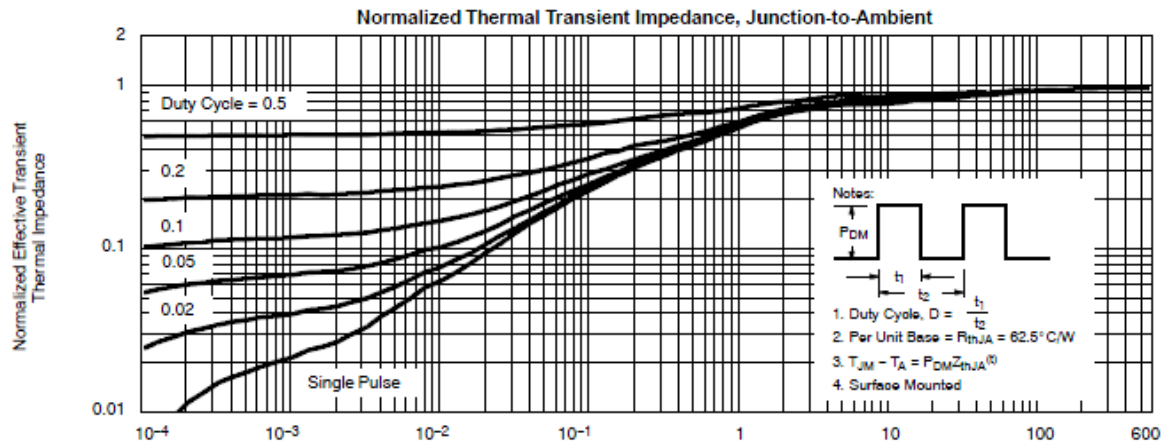
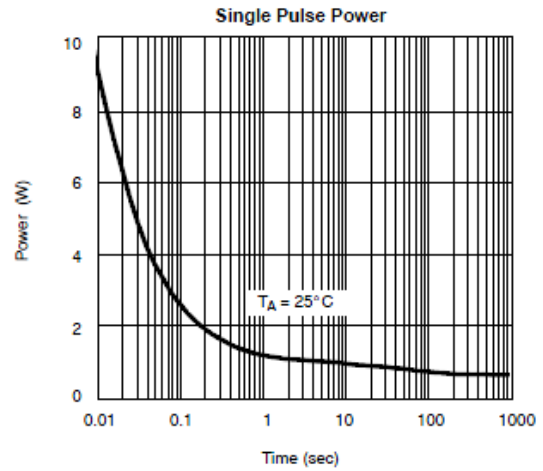
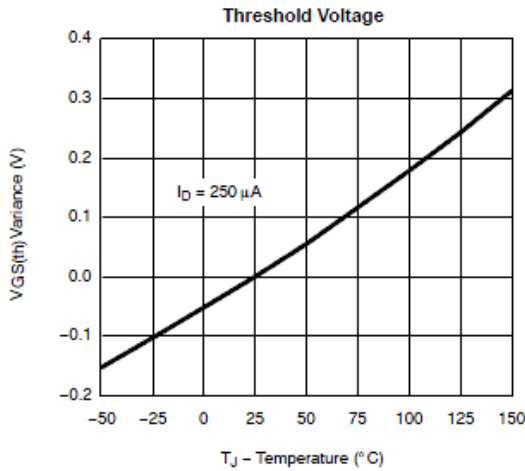
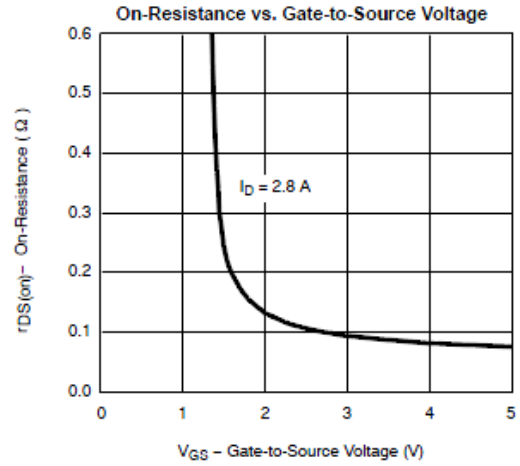
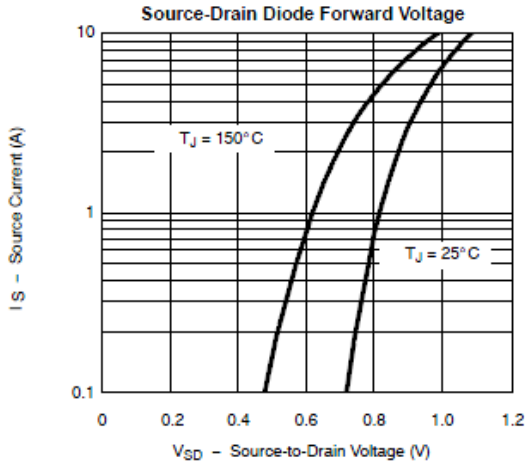



Typical Characteristics

Gate Charge Test Circuit & Waveform

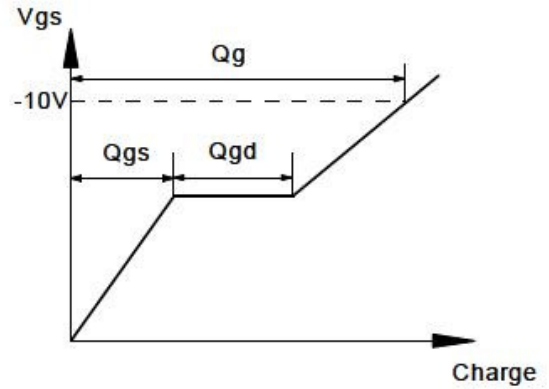
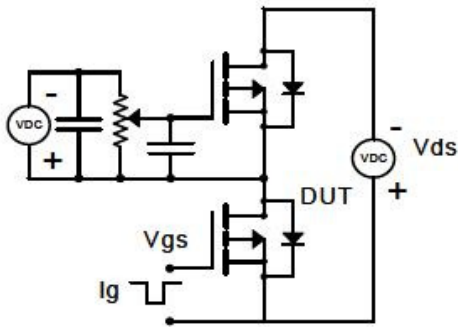

Resistive Switching Test Circuit & Waveforms

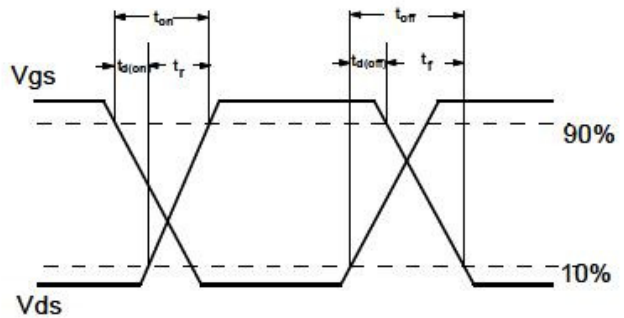
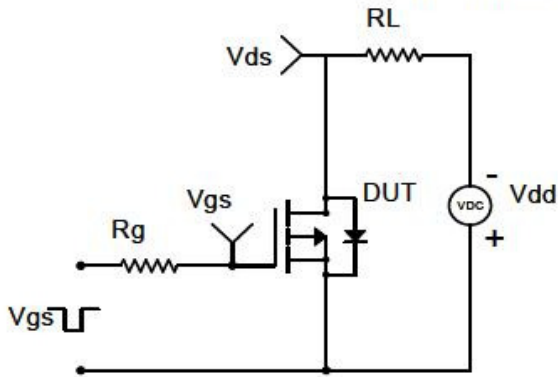

Diode Recovery Test Circuit & Waveforms

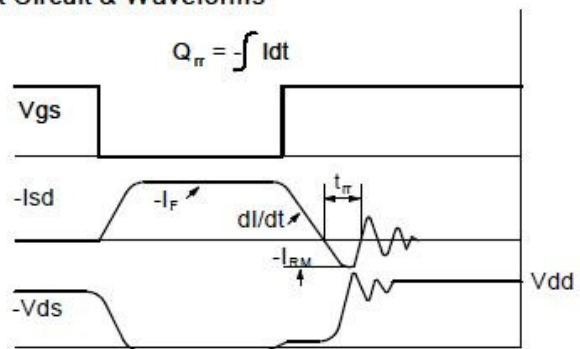
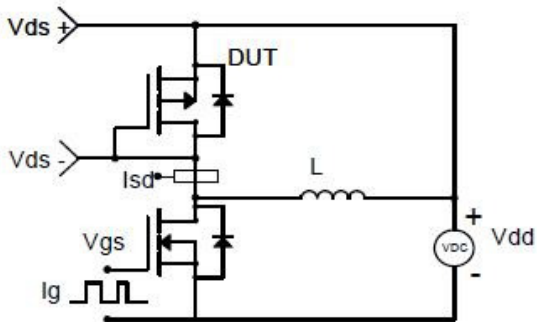



**Package Information ( SOT-23-3L )**

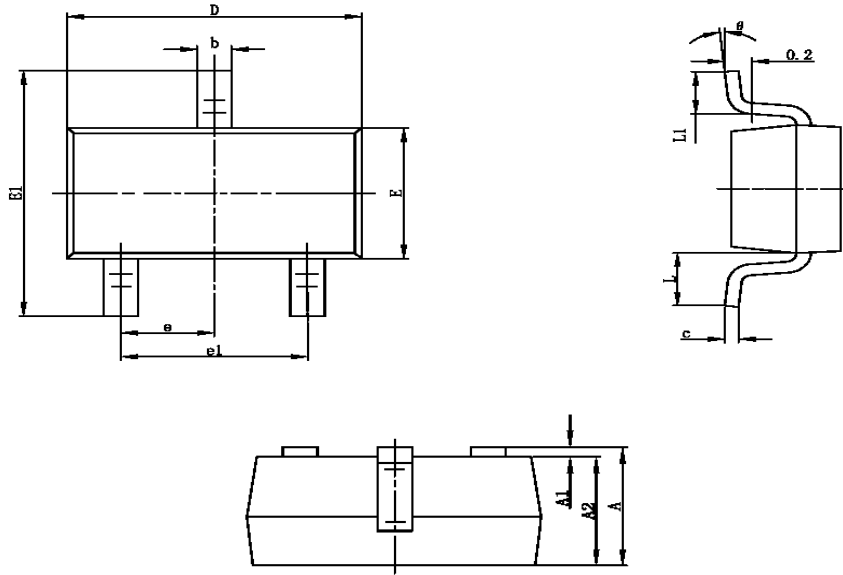

Symbol	Dimensions In Millimeters		Dimensions In Inches	
	Min	Max	Min	Max
A	1.050	1.250	0.041	0.049
A1	0.000	0.100	0.000	0.004
A2	1.050	1.150	0.041	0.045
b	0.300	0.400	0.012	0.016
c	0.100	0.200	0.004	0.008
D	2.820	3.020	0.111	0.119
E	1.500	1.700	0.059	0.067
E1	2.650	2.950	0.104	0.116
e	0.950TYP		0.037TYP	
e1	1.800	2.000	0.071	0.079
L	0.700REF		0.028REF	
L1	0.300	0.600	0.012	0.024
θ	0°	8°	0°	8°

©2010 Alfa-MOS Technology Corp.  
 2F, No.80, Sec.1, Cheng Kung Rd., Nan Kang Dist., Taipei City 115, Taiwan (R.O.C.)  
 Tel : 886 2) 2651 3928  
 Fax : 886 2) 2786 8483  
 ©http://www.alfa-mos.com