



General Description

AFP3447W, P-Channel enhancement mode MOSFET, uses Advanced Trench Technology to provide excellent $R_{DS(ON)}$, low gate charge.

These devices are particularly suited for low voltage power management, and low in-line power loss are needed in commercial industrial surface mount applications.

Features

- $I_D = -1.0A, R_{DS(ON)} = 1500m\Omega @ V_{GS} = -10V$
- $I_D = -0.5A, R_{DS(ON)} = 1700m\Omega @ V_{GS} = -4.5V$
- Super high density cell design for extremely low $R_{DS(ON)}$
- Exceptional on-resistance and maximum DC current capability
- ESD Protection Design
- SOT-23-6L package design

Pin Description (SOT-23-6L)

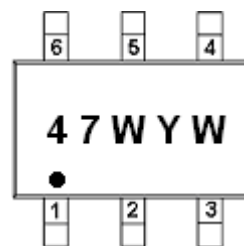
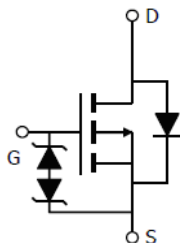
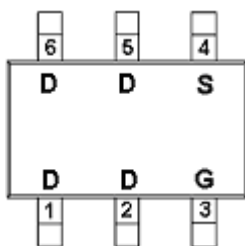

Application

- Active Clamp Circuits in DC/DC Power Supplies

Pin Define

Pin	Symbol	Description
1	D	Drain
2	D	Drain
3	G	Gate
4	S	Source
5	D	Drain
6	D	Drain

Ordering Information

Part Ordering No.	Part Marking	Package	Unit	Quantity
AFP3447WS26RG	47WYW	SOT-23-6L	Tape & Reel	3000 EA

※ 47W parts code

※ Y year code (0 ~ 9)

※ W week code (A ~ Z = 1 ~ 26 / a ~ z = 27 ~ 52)

※ AFP3447WS26RG : 7" Tape & Reel ; Pb- Free ; Halogen -Free



Absolute Maximum Ratings

(T_A=25°C Unless otherwise noted)

Parameter	Symbol	Value	Unit
Drain-Source Voltage	V _{DSS}	-120	V
Gate –Source Voltage	V _{GSS}	±20	V
Continuous Drain Current(T _J =150°C)	I _D	T _c =25°C	-1.0
		T _c =70°C	-0.5
Pulsed Drain Current	I _{DM}	-1.2	A
Continuous Source Current(Diode Conduction)	I _S	-1.2	A
Power Dissipation	P _D	T _A =25°C	2.0
		T _A =70°C	1.3
Operating Junction Temperature	T _J	150	°C
Storage Temperature Range	T _{STG}	-55/150	°C
Thermal Resistance-Junction to Ambient	R _{θJA}	120	°C/W

Electrical Characteristics

(T_A=25°C Unless otherwise noted)

Parameter	Symbol	Conditions	Min.	Typ	Max.	Unit
Static						
Drain-Source Breakdown Voltage	V _{(BR)DSS}	V _{GS} =0V, I _D =-250uA	-120			V
Gate Threshold Voltage	V _{GS(th)}	V _{DS} =V _{GS} , I _D =-250uA	-1.0		-2.0	
Gate Leakage Current	I _{GSS}	V _{DS} =0V, V _{GS} =±20V			±10	uA
Zero Gate Voltage Drain Current	I _{DSS}	V _{DS} =-100V, V _{GS} =0V			-1	uA
		V _{DS} =-100V, V _{GS} =0V T _J =85°C			-30	
On-State Drain Current	I _{D(on)}	V _{DS} ≥ -10V, V _{GS} =-10V	-1.2			A
Drain-Source On-Resistance	R _{DS(on)}	V _{GS} =-10V, I _D =-1.0A		1250	1500	mΩ
		V _{GS} =-4.5V, I _D =-0.5A		1400	1700	
Forward Transconductance	g _{FS}	V _{DS} =-10V, I _D =-1.0A		4.5		S
Diode Forward Voltage	V _{SD}	I _S =-1.0A, V _{GS} =0V		-0.75	-1.2	V
Dynamic						
Total Gate Charge	Q _g	V _{DS} =-75V, V _{GS} =-6V I _D ≡-1.0A		8	12	nC
Gate-Source Charge	Q _{gs}			2		
Gate-Drain Charge	Q _{gd}			4		
Input Capacitance	C _{iss}	V _{DS} =250V, V _{GS} =0V f=1MHz		380		pF
Output Capacitance	C _{oss}			30		
Reverse Transfer Capacitance	C _{rss}			20		
Turn-On Time	t _{d(on)}	V _{DD} =-75V, R _L =75Ω I _D ≡-1.0A, V _{GEN} =-10V R _G =1.0Ω		10	20	ns
	t _r			12	25	
Turn-Off Time	t _{d(off)}			25	50	
	t _f			12	25	



Typical Characteristics

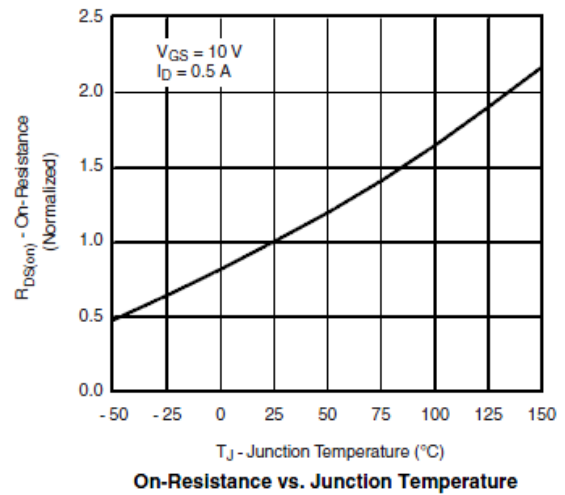
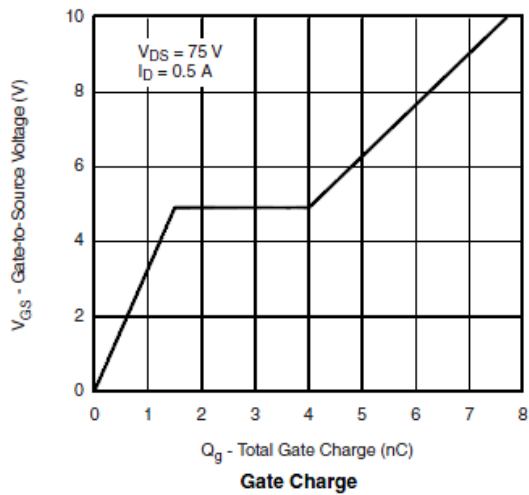
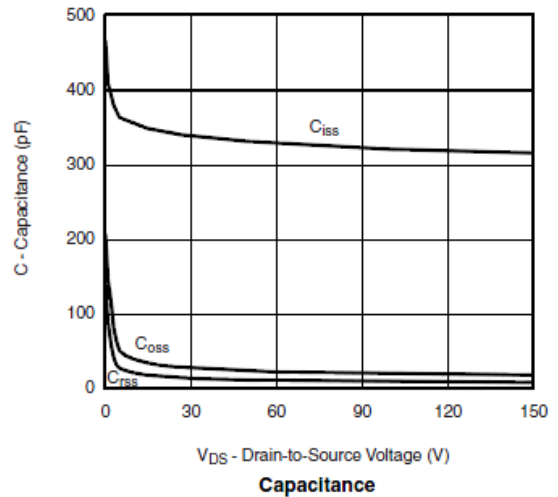
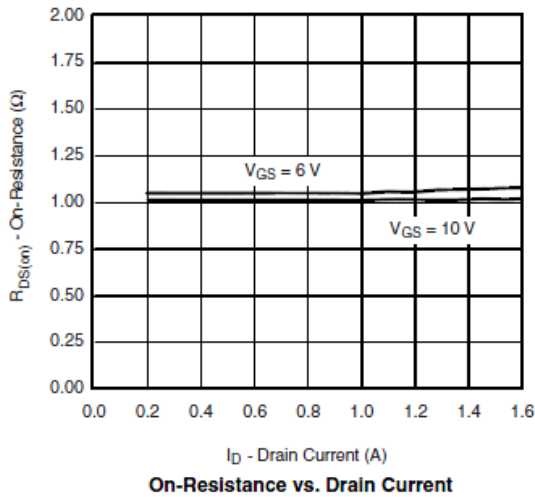
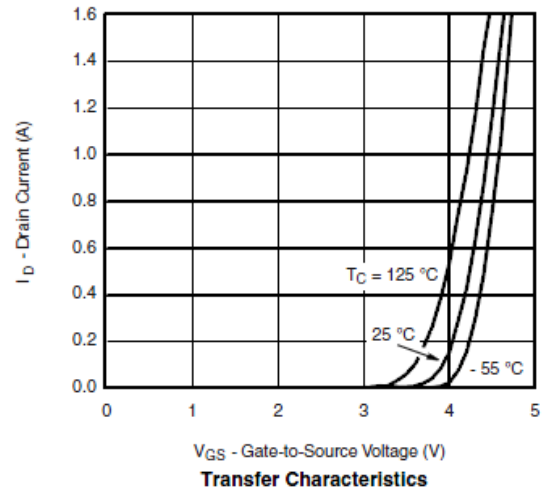
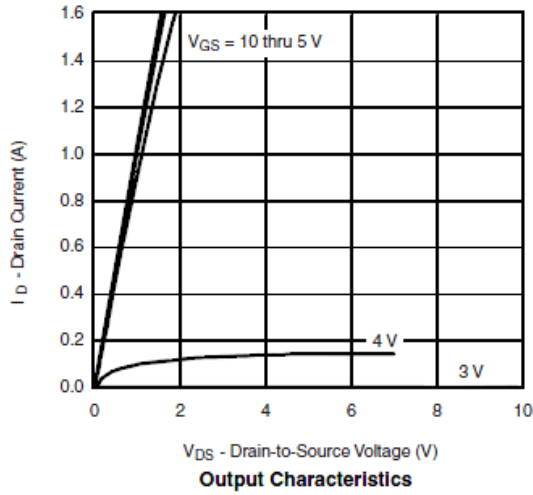



Typical Characteristics

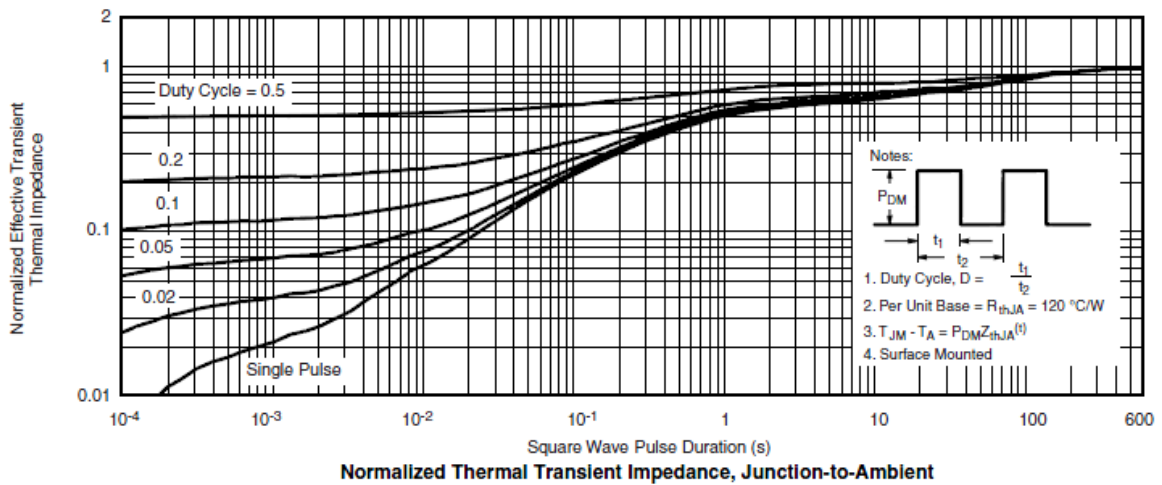
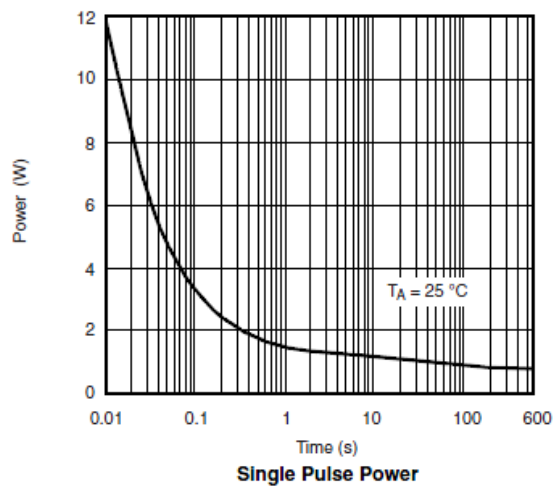
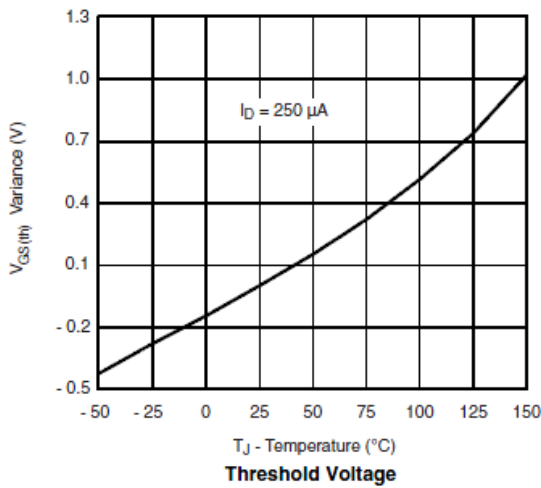
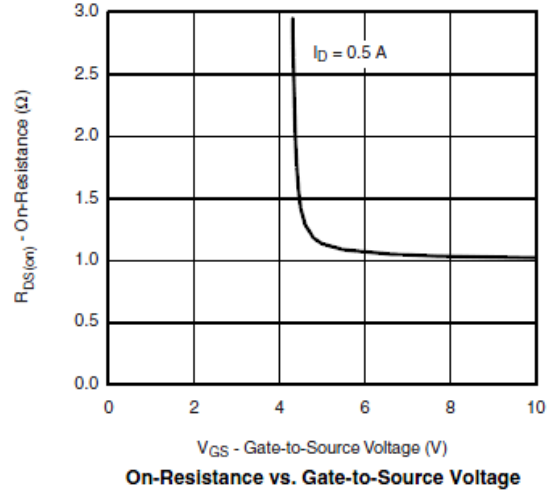
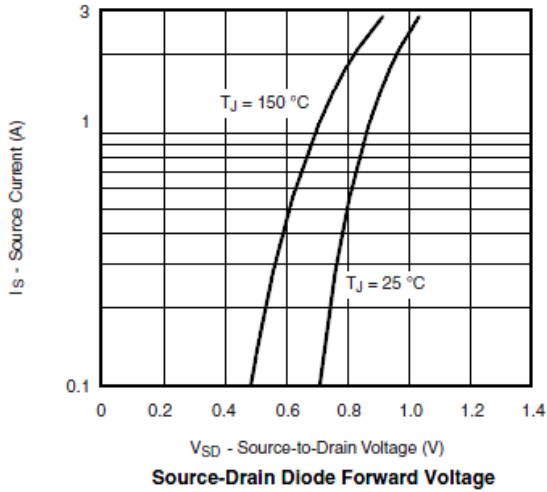



Typical Characteristics

Gate Charge Test Circuit & Waveform

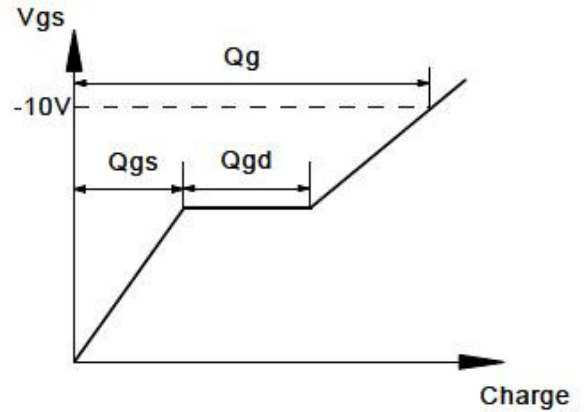
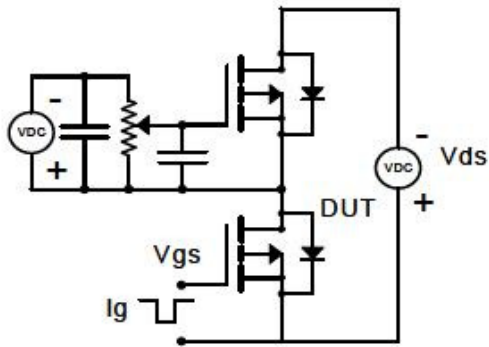

Resistive Switching Test Circuit & Waveforms

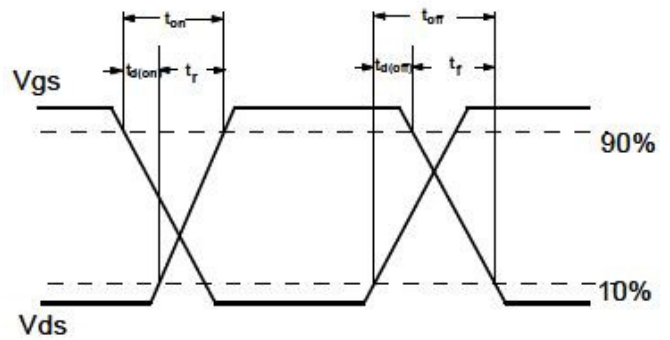
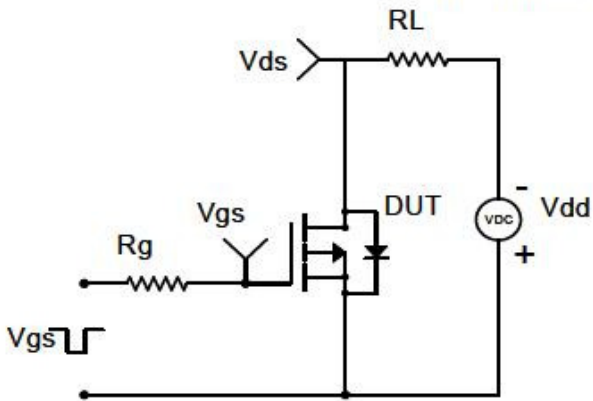

Diode Recovery Test Circuit & Waveforms

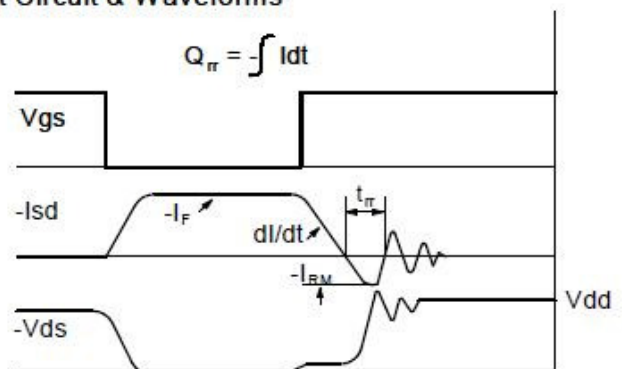
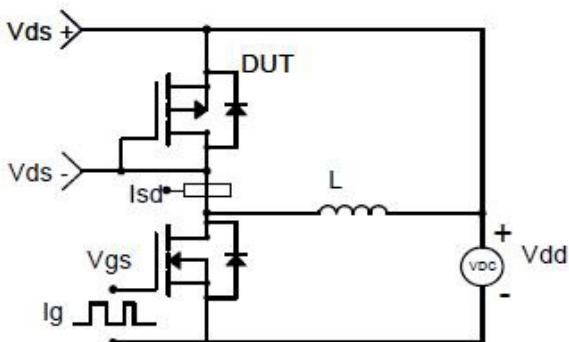



Package Information (SOT-23-6L)

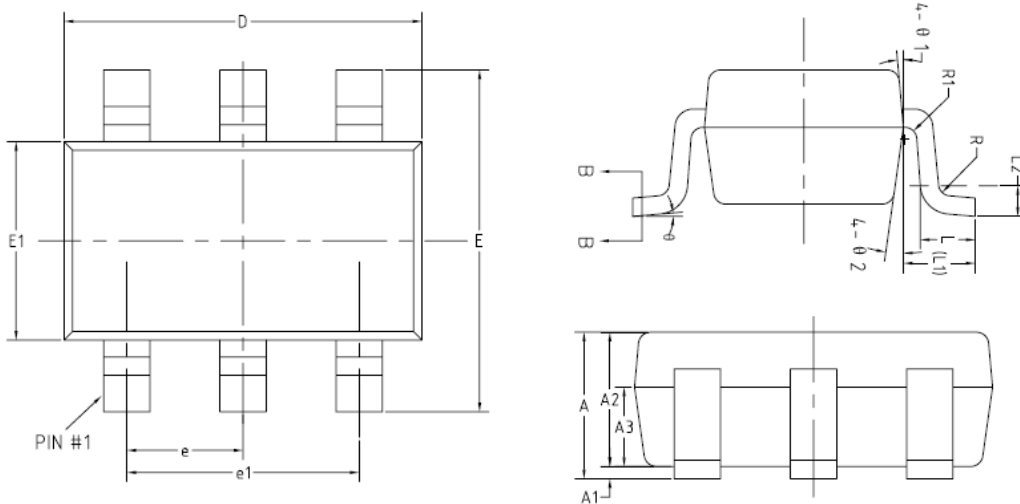

(UNITS OF MEASURE=MILLIMETER)

SYMBOL	MIN	NOM	MAX
A	—	—	1.45
A1	0	—	0.15
A2	0.90	1.10	1.30
A3	0.60	0.65	0.70
b	0.39	—	0.49
b1	0.38	0.40	0.45
c	0.12	—	0.19
c1	0.11	0.13	0.15
D	2.85	2.95	3.05
E	2.60	2.80	3.00
E1	1.55	1.65	1.75
e	0.85	0.95	1.05
e1	1.80	1.90	2.00
L	0.35	0.45	0.60
L1	0.59REF		
L2	0.25BSC		
R	0.05	—	—
R1	0.05	—	0.20
θ	0°	—	8°
θ 1	8°	10°	12°
θ 2	8°	10°	12°

©2010 Alfa-MOS Technology Corp.
2F, No.80, Sec.1, Cheng Kung Rd., Nan Kang Dist., Taipei City 115, Taiwan (R.O.C.)
Tel : 886 2) 2651 3928
Fax : 886 2) 2786 8483
©http://www.alfa-mos.com