



General Description

AFP5625S, P-Channel enhancement mode MOSFET, uses Advanced Trench Technology to provide excellent $R_{DS(ON)}$, low gate charge.

These devices are particularly suited for low voltage power management, and low in-line power loss are needed in commercial industrial surface mount applications.

Features

- $I_D = -25A, R_{DS(ON)} = 26m\Omega @ V_{GS} = -10V$
- $I_D = -15A, R_{DS(ON)} = 36m\Omega @ V_{GS} = -4.5V$
- Super high density cell design for extremely low $R_{DS(ON)}$
- DFN5X6-8L package design

Pin Description (DFN5X6-8L)

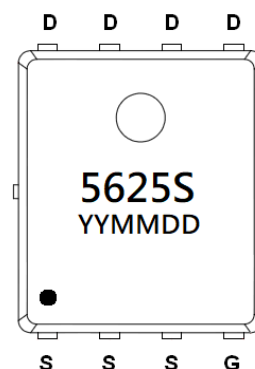
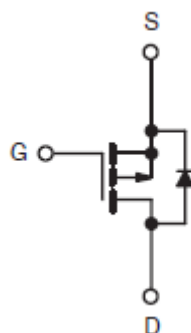
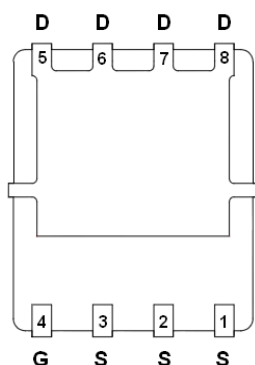

Application

- Load Switch
- Adaptor Switch
- Notebook PC

Pin Define

Pin	Symbol	Description
4	G	Gate
1~3	S	Source
5~8	D	Drain

Ordering Information

Part Ordering No.	Part Marking	Package	Unit	Quantity
AFP5625SFN568RG	5625S	DFN5X6-8L	Tape & Reel	2500 EA

- ※ 5625S : Parts Code
- ※ YYMMDD : Date Code
- ※ AFP5625SFN568RG : 13" Tape & Reel ; Pb- Free ; Halogen- Free



Absolute Maximum Ratings ($T_A=25^\circ\text{C}$ Unless otherwise noted)

Parameter	Symbol	Typical	Unit
Drain-Source Voltage	V_{DSS}	-60	V
Gate -Source Voltage	V_{GSS}	± 20	V
Continuous Drain Current ($T_J=150^\circ\text{C}$)	I_{DSM}	$T_c=25^\circ\text{C}$	-35
		$T_c=70^\circ\text{C}$	-20
		$T_A=25^\circ\text{C}$	-7.8
		$T_A=75^\circ\text{C}$	-6.2
Pulsed Drain Current	I_{DM}	-40	
Continuous Source Current (Diode Conduction)	I_S	-4.3	
Single Pulse Avalanche Current	I_{AS}	-25	
Power Dissipation	P_{DSM}	$T_A=25^\circ\text{C}$	5.2
		$T_A=75^\circ\text{C}$	3.3
Operating Junction Temperature	T_J	150	$^\circ\text{C}$
Storage Temperature Range	T_{STG}	-55/150	$^\circ\text{C}$
Thermal Resistance-Junction to Ambient	$t \leq 10 \text{ s}$	$R_{\theta JA}$	19
Thermal Resistance-Junction to Case	Steady-State	$R_{\theta JC}$	1.2

Electrical Characteristics

($T_A=25^\circ\text{C}$ Unless otherwise noted)

Parameter	Symbol	Conditions	Min.	Typ	Max.	Unit
Static						
Drain-Source Breakdown Voltage	$V_{(BR)DSS}$	$V_{GS}=0V, I_D = -250\mu\text{A}$	-60			V
Gate Threshold Voltage	$V_{GS(th)}$	$V_{DS}=V_{GS}, I_D = -250\mu\text{A}$	-1.0		-2.0	
Gate Leakage Current	I_{GSS}	$V_{DS}=0V, V_{GS} = \pm 20V$			± 100	nA
Zero Gate Voltage Drain Current	I_{DSS}	$V_{DS} = -48V, V_{GS}=0V$			-1	uA
		$V_{DS} = -48V, V_{GS}=0V$ $T_J=85^\circ\text{C}$			-20	
On-State Drain Current	$I_{D(on)}$	$V_{DS} \geq -5V, V_{GS} = -10V$	-40			A
Drain-Source On-Resistance	$R_{DS(on)}$	$V_{GS} = -10V, I_D = -25A$		20	26	m Ω
		$V_{GS} = -4.5V, I_D = -15A$		28	36	
Forward Transconductance	g_{FS}	$V_{DS} = -15V, I_D = -15A$		45		S
Diode Forward Voltage	V_{SD}	$I_S = -3A, V_{GS}=0V$		-0.8	-1.3	V
Dynamic						
Total Gate Charge	Q_g	$V_{DS} = -30V, V_{GS} = -4.5V$ $I_D = -15.0A$		50	95	nC
Gate-Source Charge	Q_{gs}			15		
Gate-Drain Charge	Q_{gd}			25		
Input Capacitance	C_{iss}	$V_{DS} = -30V, V_{GS} = 0V$ $f = 1\text{MHz}$		4200		pF
Output Capacitance	C_{oss}			300		
Reverse Transfer Capacitance	C_{rss}			210		
Turn-On Time	$t_{d(on)}$	$V_{DD} = -30V, R_L = 3.8\Omega$ $I_D = -15.0A, V_{GEN} = -10V$ $R_G = 1.0\Omega$		45	80	ns
	t_r			220	380	
Turn-Off Time	$t_{d(off)}$			95	185	
	t_f			110	200	



Typical Characteristics

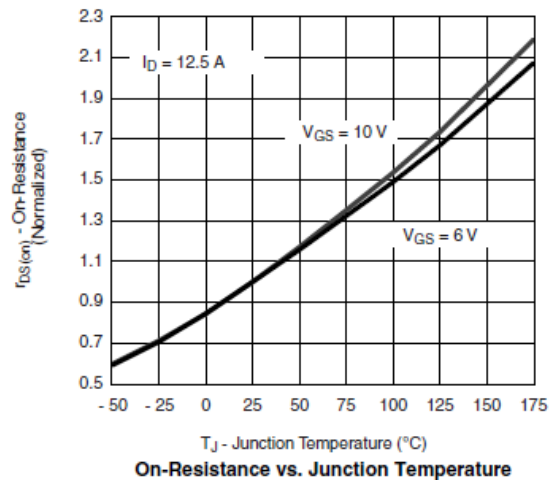
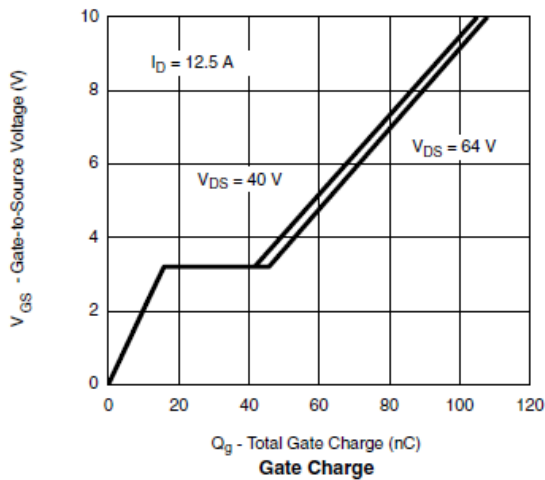
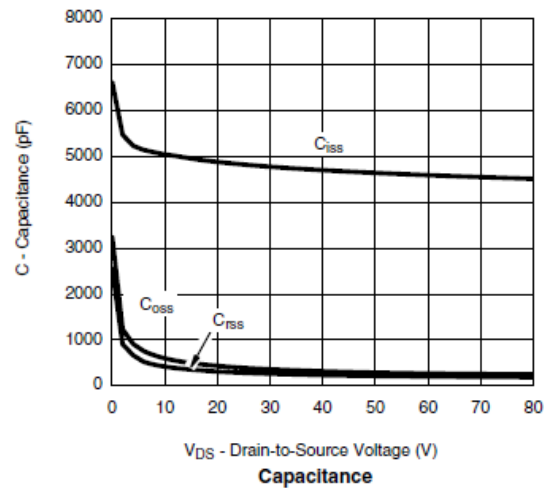
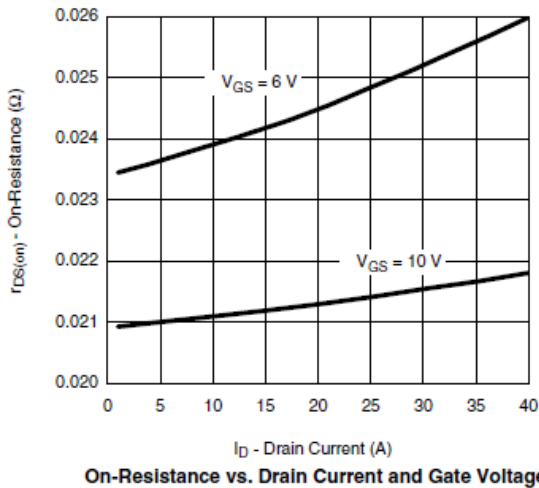
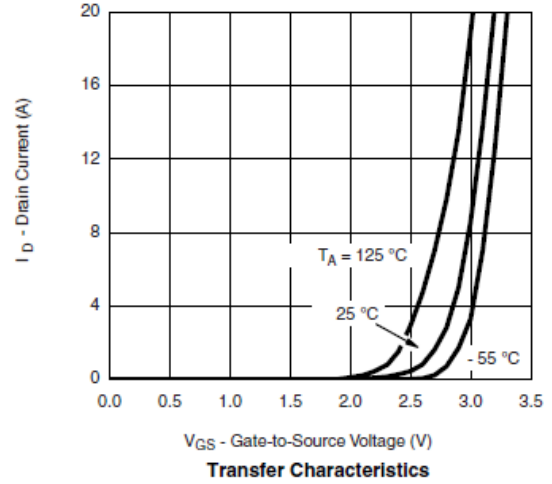
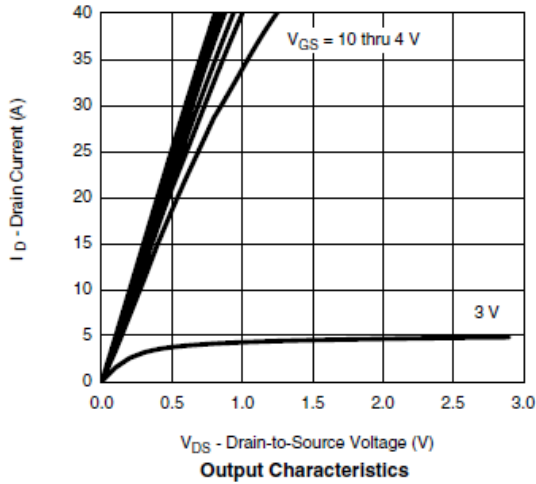



Typical Characteristics

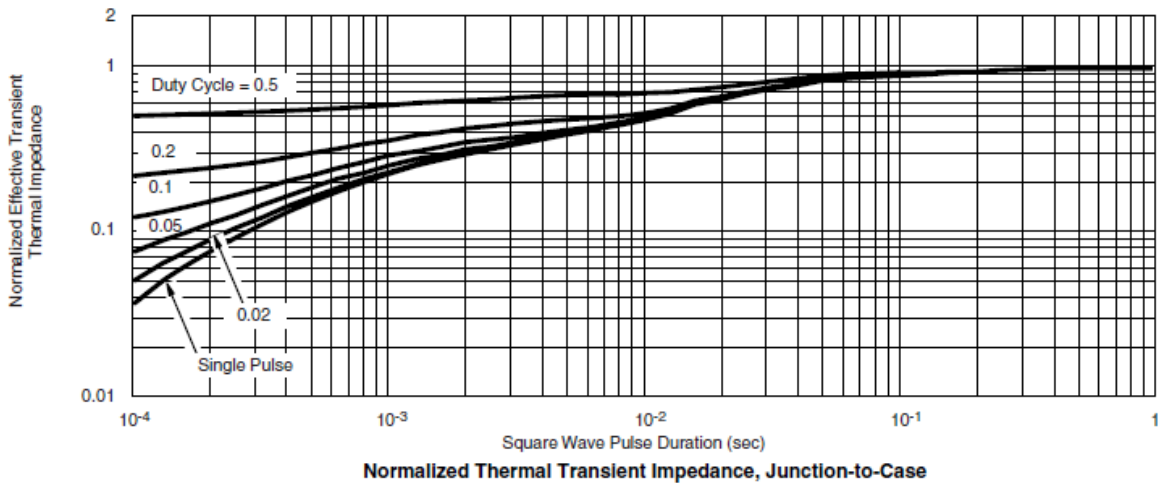
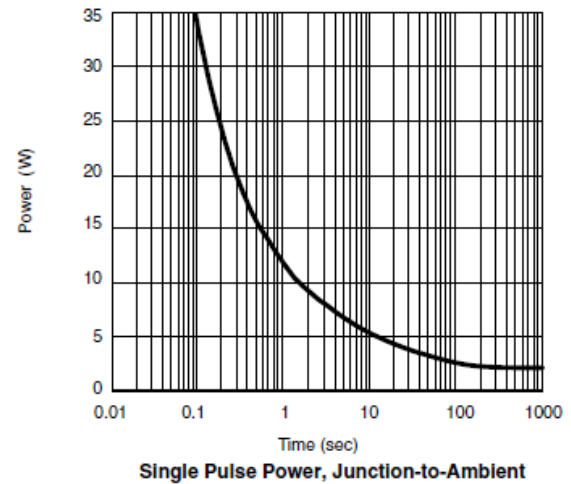
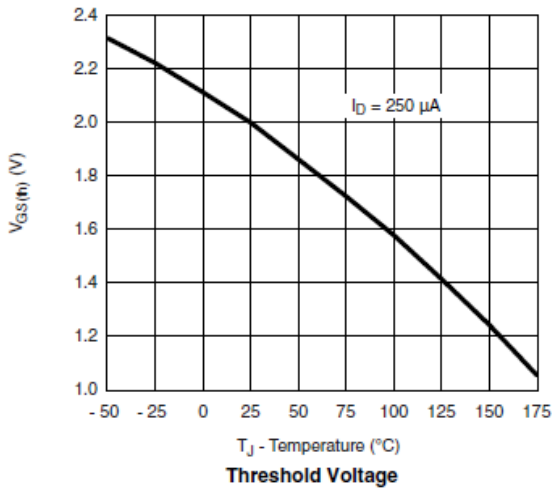
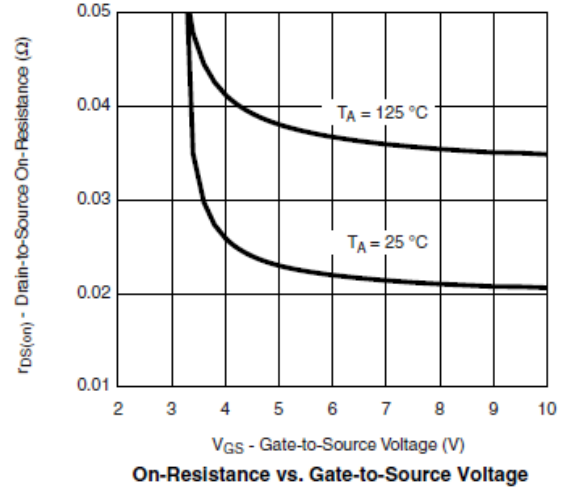
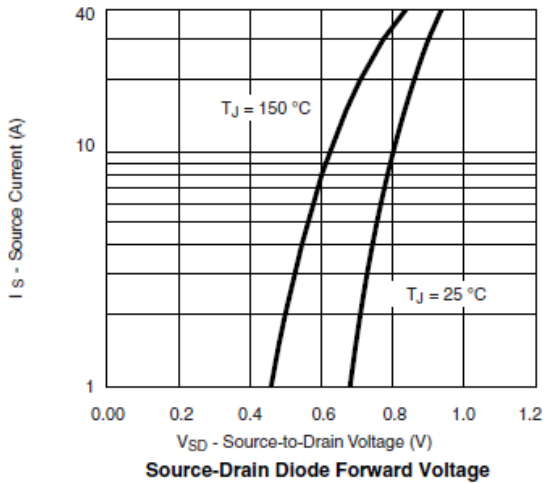



Typical Characteristics

Gate Charge Test Circuit & Waveform

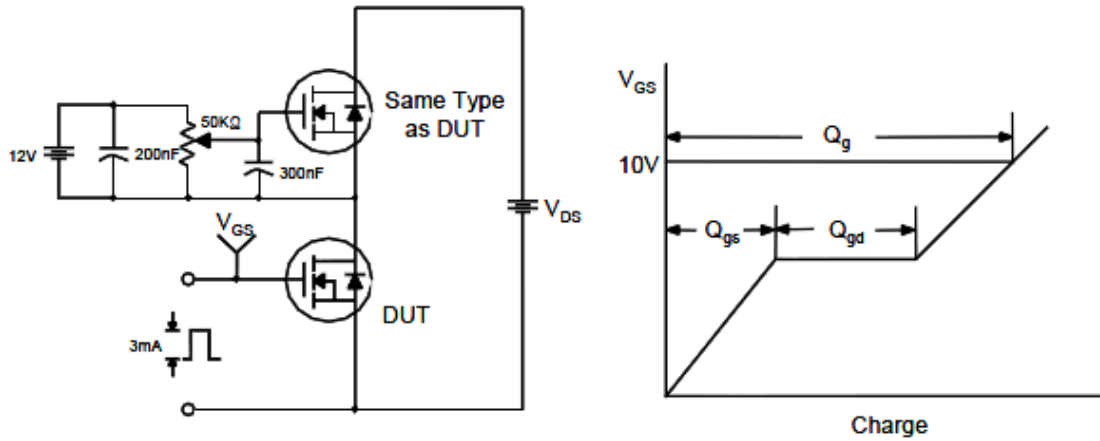

Resistive Switching Test Circuit & Waveforms

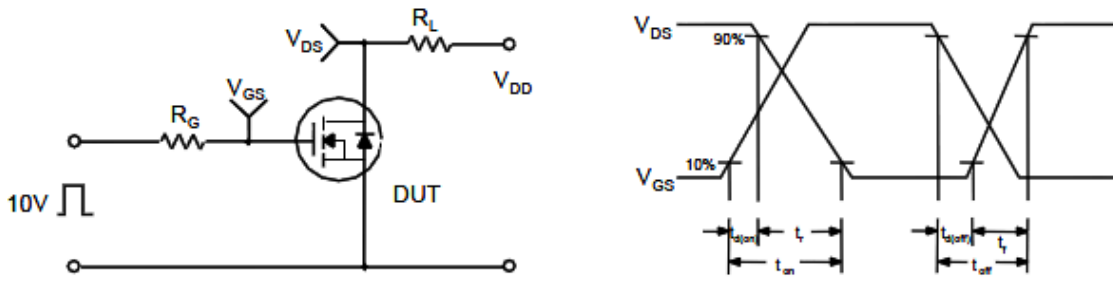

Unclamped Inductive Switching Test Circuit & Waveforms

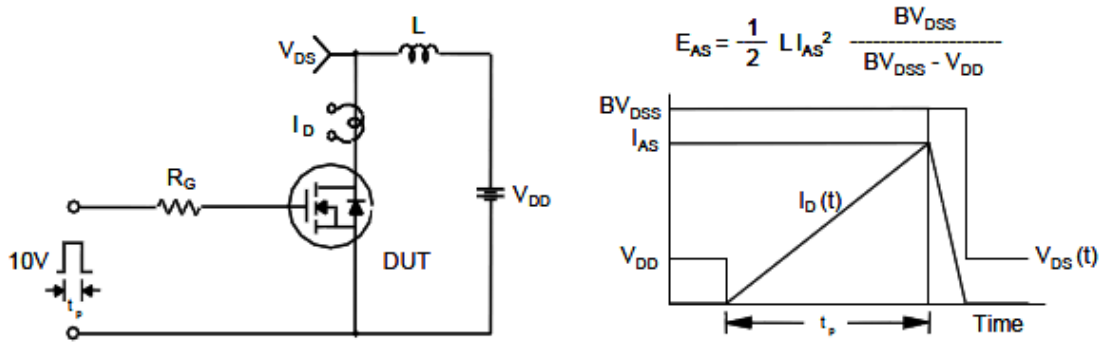



Package Information (DFN5X6-8L)

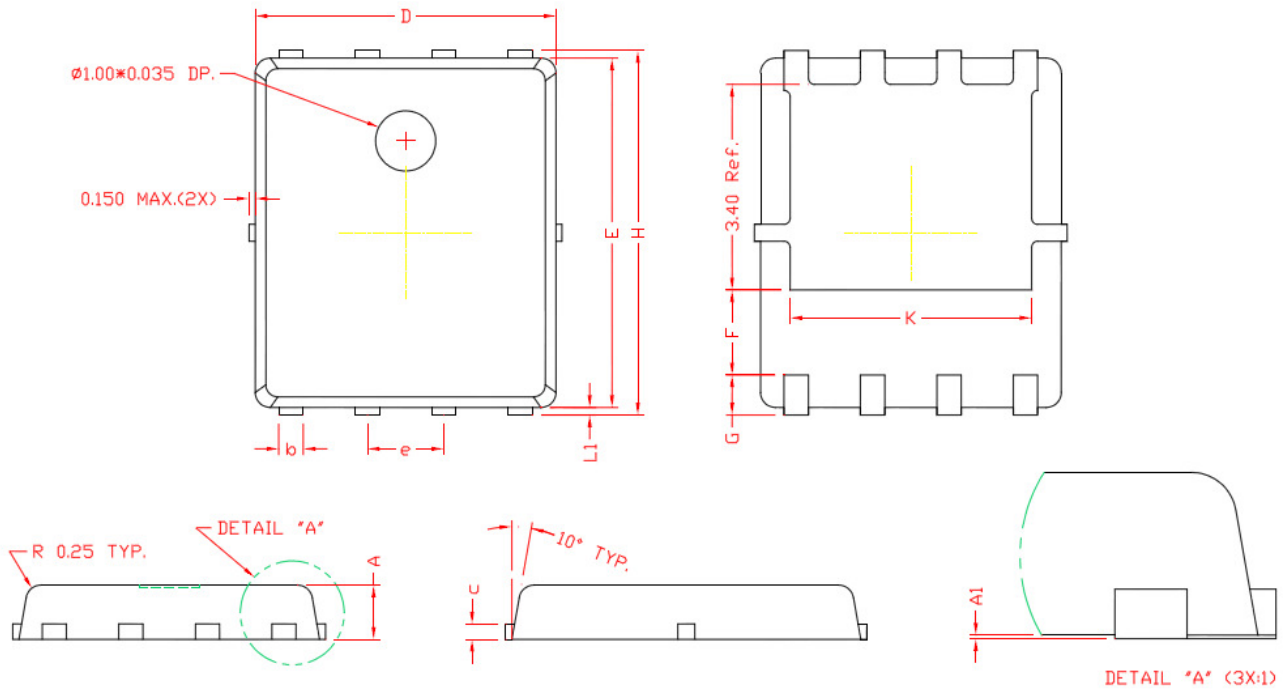

DIMENSIONS

REF.	Millimeters		REF.	Millimeters	
	Min.	Max.		Min.	Max.
A	0.80	1.00	E	5.70	5.90
A1	0.00	0.05	e	1.27 BSC.	
b	0.35	0.49	H	5.95	6.20
c	0.254 Ref.		L1	0.10	0.18
D	4.90	5.10	G	0.60 Ref.	
F	1.40 Ref.		K	4.00 Ref.	

©2010 Alfa-MOS Technology Corp.
 2F, No.80, Sec.1, Cheng Kung Rd., Nan Kang Dist., Taipei City 115, Taiwan (R.O.C.)
 Tel : 886 2) 2651 3928
 Fax : 886 2) 2786 8483
 ©http://www.alfa-mos.com