



### General Description

AFP7001KAS, P-Channel enhancement mode MOSFET, uses Advanced Trench Technology to provide excellent  $R_{DS(ON)}$ , low gate charge.

These devices are particularly suited for low voltage power management, and low in-line power loss are needed in commercial industrial surface mount applications.

### Features

- $I_D = -0.5A, R_{DS(ON)} = 5\Omega @ V_{GS} = -10V$
- $I_D = -0.1A, R_{DS(ON)} = 6\Omega @ V_{GS} = -4.5V$
- Super high density cell design for extremely low  $R_{DS(ON)}$
- Exceptional on-resistance and maximum DC current capability
- ESD Protection Diode design-in
- SOT-23 package design

### Pin Description ( SOT-23 )

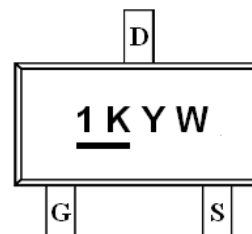
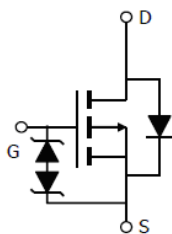
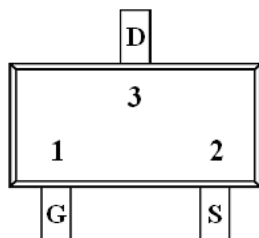

### Application

- Drivers: Relays, Solenoids, Lamps, Hammers, Display, Memories, Transistors, etc.
- Battery Operated Systems
- Power Supply Converter Circuits
- Solid-State Relays

### Pin Define

Pin	Symbol	Description
1	G	Gate
2	S	Source
3	D	Drain

### Ordering Information

Part Ordering No.	Part Marking	Package	Unit	Quantity
AFP7001KASS23RG	<u>1</u> KYW	SOT-23	Tape & Reel	3000 EA

※ 1K parts code

※ Y year code ( 0 ~ 9 )

※ W week code ( A ~ Z = 1 ~ 26 / a ~ z = 27 ~ 52 )

※ AFP7001KASS23RG : 7" Tape & Reel ; Pb- Free ; Halogen -Free



### Absolute Maximum Ratings

(T<sub>A</sub>=25°C Unless otherwise noted)

Parameter	Symbol	Value	Unit
Drain-Source Voltage	V <sub>DSS</sub>	-60	V
Gate –Source Voltage	V <sub>GSS</sub>	±20	V
Continuous Drain Current(T <sub>J</sub> =150°C)	I <sub>D</sub>	T <sub>A</sub> =25°C	-0.185
		T <sub>A</sub> =70°C	-0.115
Pulsed Drain Current	I <sub>DM</sub>	-0.8	A
Power Dissipation	P <sub>D</sub>	T <sub>A</sub> =25°C	0.35
		T <sub>A</sub> =70°C	0.14
Operating Junction Temperature	T <sub>J</sub>	150	°C
Storage Temperature Range	T <sub>STG</sub>	-55/150	°C
Thermal Resistance-Junction to Ambient	R <sub>θJA</sub>	120	°C/W

### Electrical Characteristics

(T<sub>A</sub>=25°C Unless otherwise noted)

Parameter	Symbol	Conditions	Min.	Typ	Max.	Unit
<b>Static</b>						
Drain-Source Breakdown Voltage	V <sub>(BR)DSS</sub>	V <sub>GS</sub> =0V, I <sub>D</sub> =-250uA	-60			V
Gate Threshold Voltage	V <sub>GS(th)</sub>	V <sub>DS</sub> =V <sub>GS</sub> , I <sub>D</sub> =-250uA	-1.0		-2.0	
Gate Leakage Current	I <sub>GSS</sub>	V <sub>DS</sub> =0V, V <sub>GS</sub> =±20V			±10	uA
Zero Gate Voltage Drain Current	I <sub>DSS</sub>	V <sub>DS</sub> =-48V, V <sub>GS</sub> =0V			-1	uA
		V <sub>DS</sub> =-48V, V <sub>GS</sub> =0V T <sub>J</sub> =85°C			-30	
On-State Drain Current	I <sub>D(on)</sub>	V <sub>DS</sub> ≤ -10V, V <sub>GS</sub> =-10V	-0.6			A
Drain-Source On-Resistance	R <sub>DS(on)</sub>	V <sub>GS</sub> =-10V, I <sub>D</sub> =-0.5A		2.2	5	Ω
		V <sub>GS</sub> =-4.5V, I <sub>D</sub> =-0.1A		2.5	6	
Forward Transconductance	g <sub>FS</sub>	V <sub>DS</sub> =-10V, I <sub>D</sub> =-1.0A		2.8		S
Diode Forward Voltage	V <sub>SD</sub>	I <sub>S</sub> =-0.2A, V <sub>GS</sub> =0V		-0.75	-1.4	V
<b>Dynamic</b>						
Total Gate Charge	Q <sub>g</sub>	V <sub>DS</sub> =-30V, V <sub>GS</sub> =-15V I <sub>D</sub> =-0.5A		2		nC
Gate-Source Charge	Q <sub>gs</sub>			0.53		
Gate-Drain Charge	Q <sub>gd</sub>			0.72		
Input Capacitance	C <sub>iss</sub>	V <sub>DS</sub> =-25V, V <sub>GS</sub> =0V f=1MHz		25		pF
Output Capacitance	C <sub>oss</sub>			13		
Reverse Transfer Capacitance	C <sub>rss</sub>			7.3		
Turn-On Time	t <sub>d(on)</sub>	V <sub>DD</sub> =-25V, R <sub>L</sub> =150Ω		20		ns
Turn-Off Time	t <sub>d(off)</sub>	I <sub>D</sub> =-0.2A, V <sub>GEN</sub> =-10V, R <sub>G</sub> =10Ω		35		



## Typical Characteristics

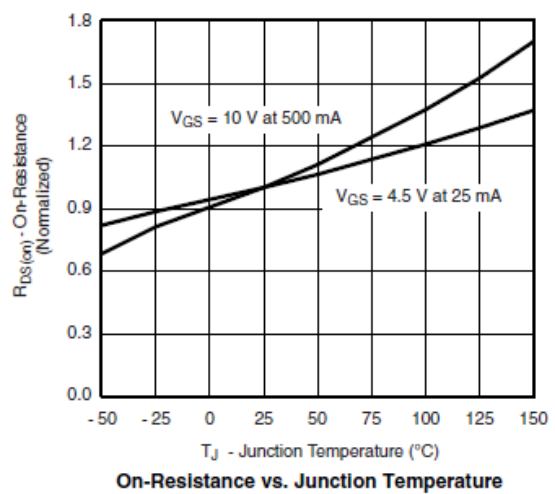
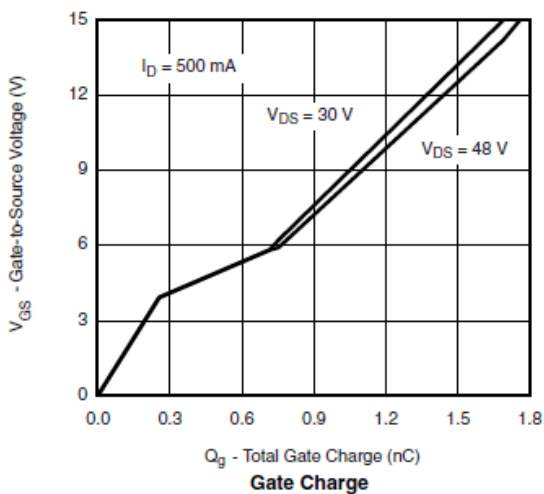
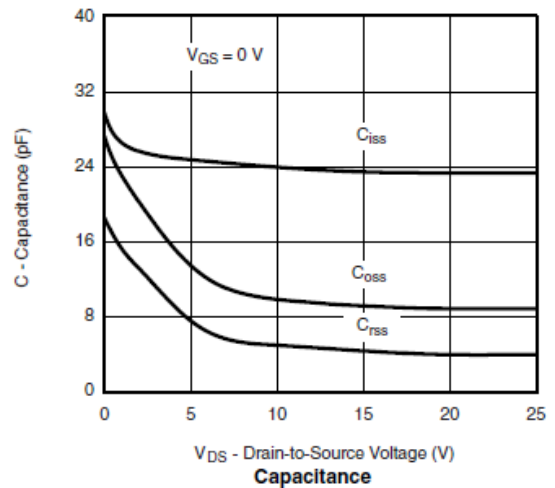
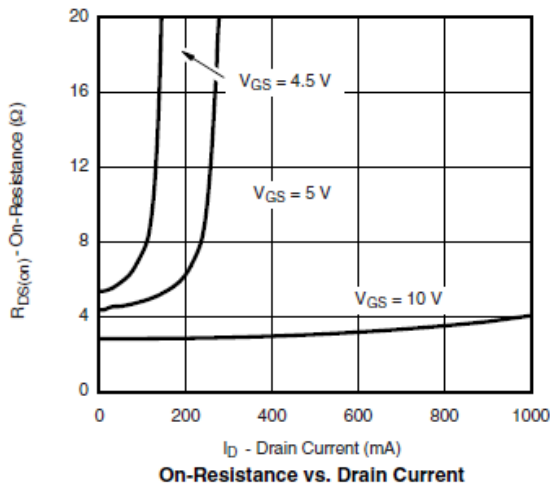
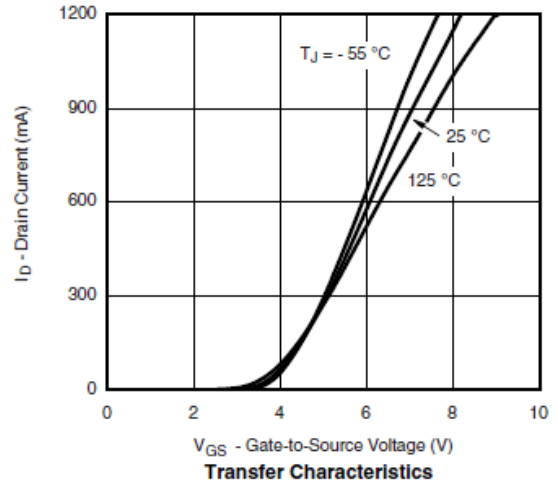
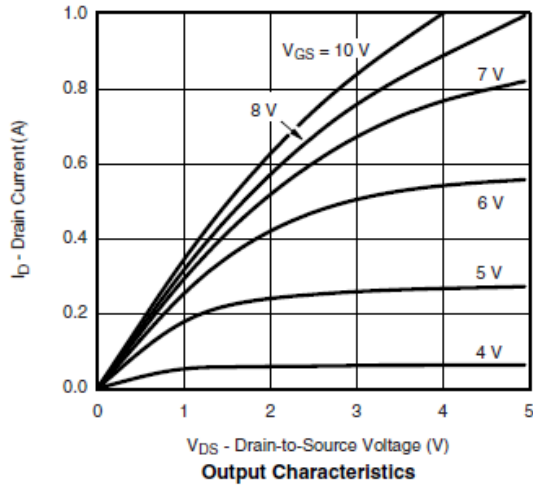



## Typical Characteristics

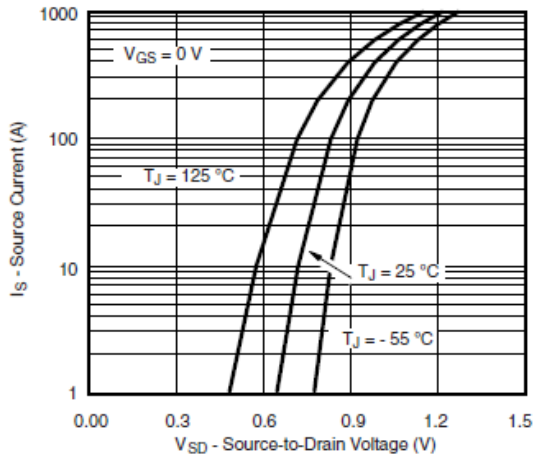

Source-Drain Diode Forward Voltage

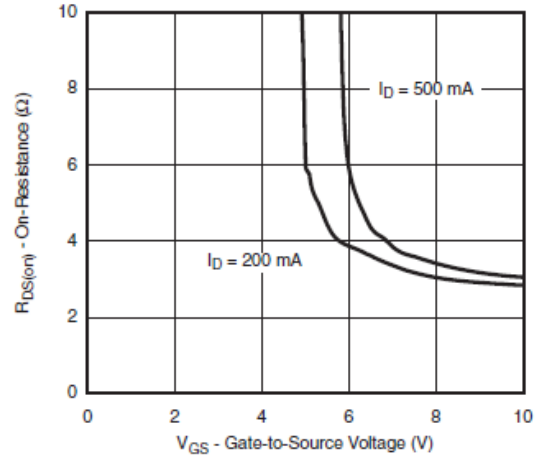

On-Resistance vs. Gate-Source Voltage

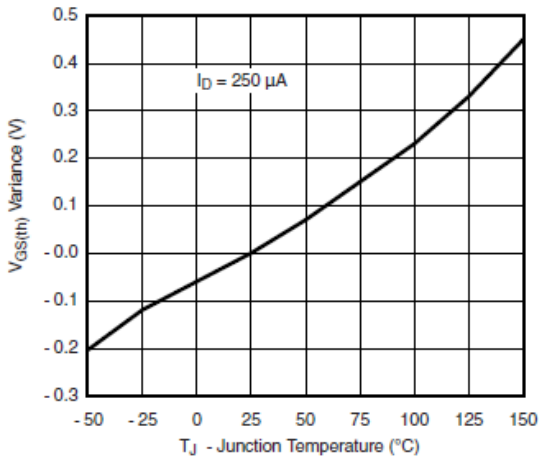

Threshold Voltage Variance Over Temperature

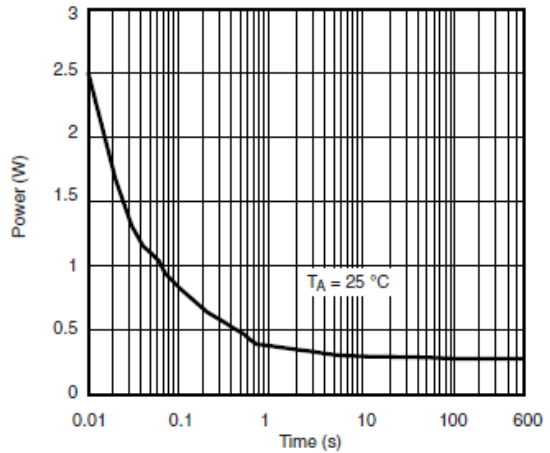

Single Pulse Power, Junction-to-Ambient

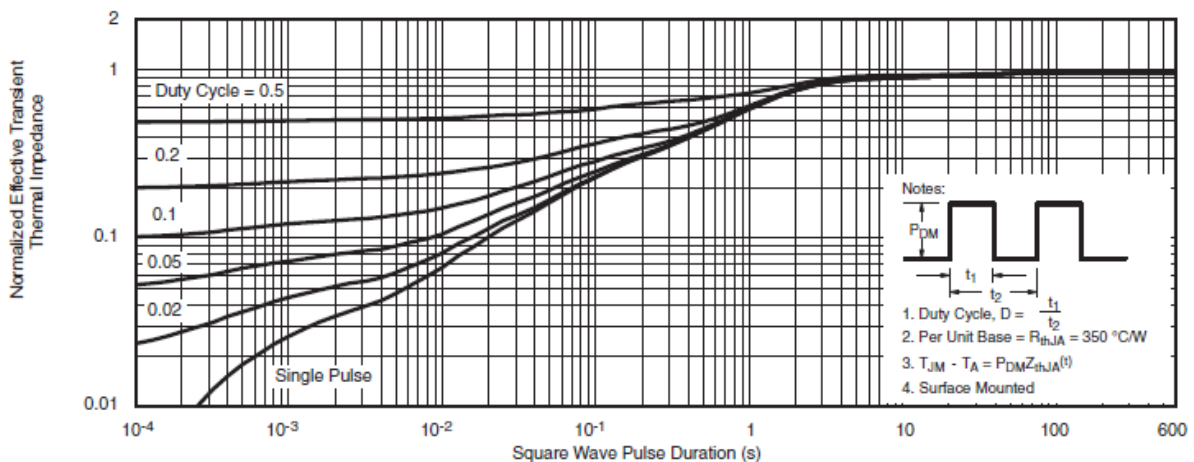

Normalized Thermal Transient Impedance, Junction-to-Ambient



**Typical Characteristics**

Gate Charge Test Circuit & Waveform

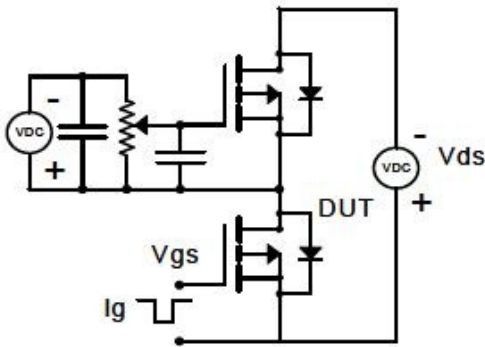

Resistive Switching Test Circuit & Waveforms

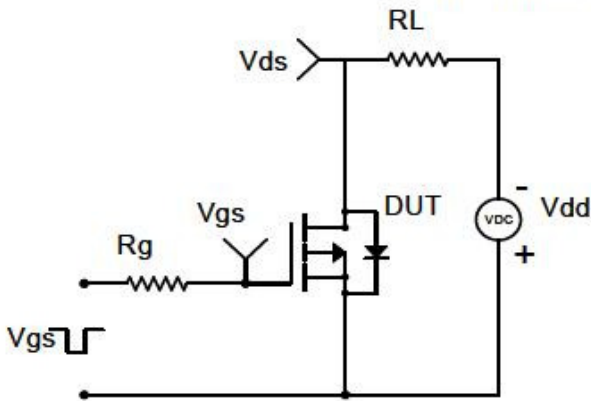

Diode Recovery Test Circuit & Waveforms

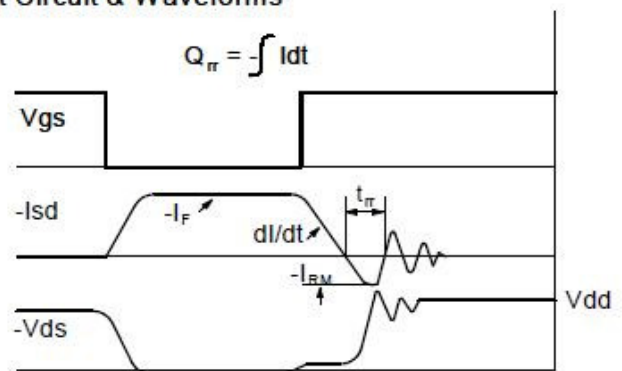
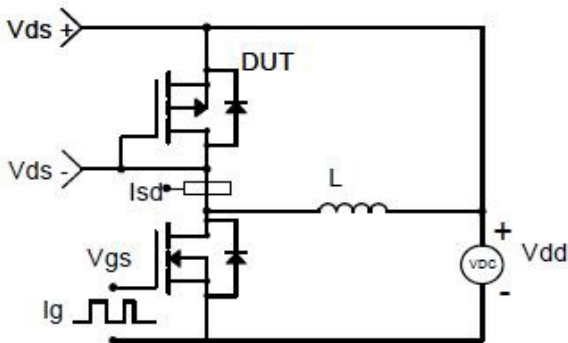



**Package Information ( SOT-23 )**

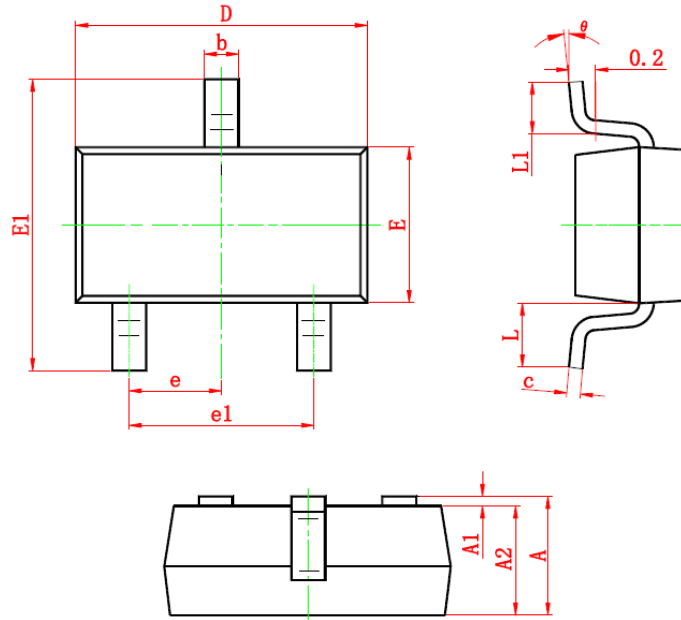

Symbol	Dimensions In Millimeters		Dimensions In Inches	
	Min	Max	Min	Max
A	0.900	1.200	0.035	0.043
A1	0.000	0.100	0.000	0.004
A2	0.900	1.100	0.035	0.039
b	0.300	0.500	0.012	0.020
c	0.080	0.150	0.003	0.006
D	2.800	3.000	0.110	0.118
E	1.200	1.400	0.047	0.055
E1	2.250	2.550	0.089	0.100
e	0.950 TYP		0.037 TYP	
e1	1.800	2.000	0.071	0.079
L	0.550 REF		0.022 REF	
L1	0.300	0.500	0.012	0.020
θ	0°	8°	0°	6°

©2010 Alfa-MOS Technology Corp.  
 2F, No.80, Sec.1, Cheng Kung Rd., Nan Kang Dist., Taipei City 115, Taiwan (R.O.C.)  
 Tel : 886 2) 2651 3928  
 Fax : 886 2) 2786 8483  
 ©http://www.alfa-mos.com