



General Description

AFP7939AS, Dual P-Channel enhancement mode MOSFET, uses Advanced Trench Technology to provide excellent $R_{DS(ON)}$, low gate charge.

These devices are particularly suited for low voltage power management, and low in-line power loss are needed in commercial industrial surface mount applications.

Features

- $I_D = -15A, R_{DS(ON)} = 13m\Omega @ V_{GS} = -10V$
- $I_D = -10A, R_{DS(ON)} = 16m\Omega @ V_{GS} = -4.5V$ Super high density cell design for extremely low $R_{DS(ON)}$
- DFN 5X6-8L package design

Pin Description (DFN5X6-8L)

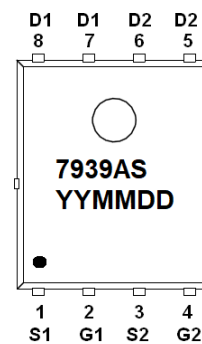
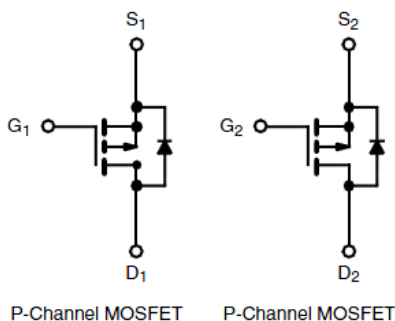
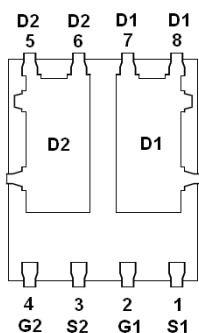

Application

- Motor and Load Control
- Backlight Inverter for LCD Display
- Full Bridge DC/DC Converter

Pin Define

Pin	Symbol	Description
1	S1	Source 1
2	G1	Gate 1
3	S2	Source 2
4	G2	Gate 2
5	D2	Drain 2
6	D2	Drain 2
7	D1	Drain 1
8	D1	Drain 1

Ordering Information

Part Ordering No.	Part Marking	Package	Unit	Quantity
AFP7939ASFN568RG	7939AS	DFN 5X6-8L	Tape & Reel	2500 EA

※ 7939AS : Parts Code

※ YYMMDD : Date Code

※ AFP7939ASFN568RG : 13" Tape & Reel ; Pb- Free ; Halogen -Free



Absolute Maximum Ratings

(T_A=25°C Unless otherwise noted)

Parameter	Symbol	Typical	Unit
Drain-Source Voltage	V _{DSS}	-40	V
Gate –Source Voltage	V _{GSS}	±20	V
Continuous Drain Current(T _J =150°C)	I _D	T _A =25°C	-15
		T _A =85°C	-10
Pulsed Drain Current	I _{DM}	-40	A
Continuous Source Current(Diode Conduction)	I _S	-2.9	A
Power Dissipation	P _D	T _A =25°C	3.5
		T _A =70°C	2.2
Operating Junction Temperature	T _J	150	°C
Storage Temperature Range	T _{STG}	-55/150	°C
Thermal Resistance-Junction to Ambient	R _{θJA}	62.5	°C/W

Electrical Characteristics

(T_A=25°C Unless otherwise noted)

Parameter	Symbol	Conditions	Min.	Typ	Max.	Unit
Static						
Drain-Source Breakdown Voltage	V _{(BR)DSS}	V _{GS} =0V, I _D = -250uA	-40			V
Gate Threshold Voltage	V _{GS(th)}	V _{DS} =V _{GS} , I _D = -250uA	-1.0		-2.0	
Gate Leakage Current	I _{GSS}	V _{DS} =0V, V _{GS} = ±20V			±100	nA
Zero Gate Voltage Drain Current	I _{DSS}	V _{DS} = -32V, V _{GS} =0V			-1	uA
		V _{DS} = -32V, V _{GS} =0V T _J =85°C			-20	
On-State Drain Current	I _{D(on)}	V _{DS} ≥ -10V, V _{GS} = -10V	-15			A
Drain-Source On-Resistance	R _{DS(on)}	V _{GS} = -10V, I _D = -15A		10	13	mΩ
		V _{GS} = -4.5V, I _D = -10A		13	16	
Forward Transconductance	g _{FS}	V _{DS} = -10V, I _D = -15A		40		S
Diode Forward Voltage	V _{SD}	I _S = -1A, V _{GS} =0V		-0.8	-1.3	V
Dynamic						
Total Gate Charge	Q _g	V _{DS} =-20V, V _{GS} =-4.5V I _D = -10A		45	90	nC
Gate-Source Charge	Q _{gs}			10		
Gate-Drain Charge	Q _{gd}			20		
Input Capacitance	C _{iss}	V _{DS} =-20V, V _{GS} =0V f=1MHz		4150		pF
Output Capacitance	C _{oss}			435		
Reverse Transfer Capacitance	C _{rss}			400		
Turn-On Time	t _{d(on)}	V _{DD} =-20V, R _L =2Ω I _D ≡ -10A, V _{GEN} =-10V R _G =1Ω		15	30	ns
	t _r			15	30	
Turn-Off Time	t _{d(off)}			55	110	
	t _f			12	25	



Typical Characteristics

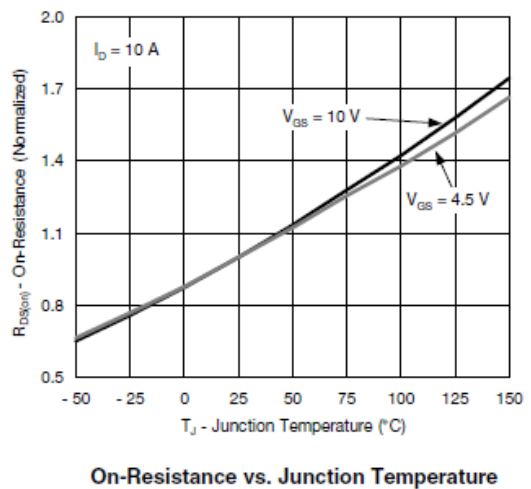
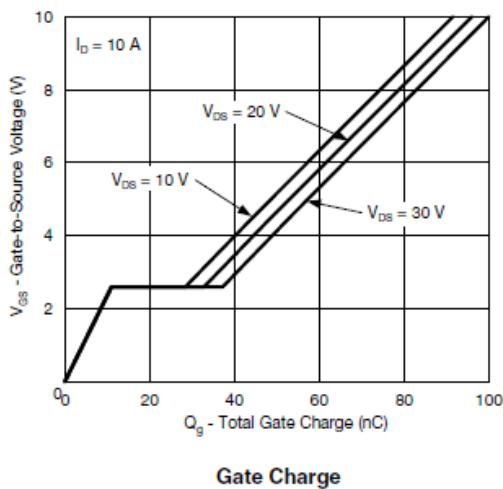
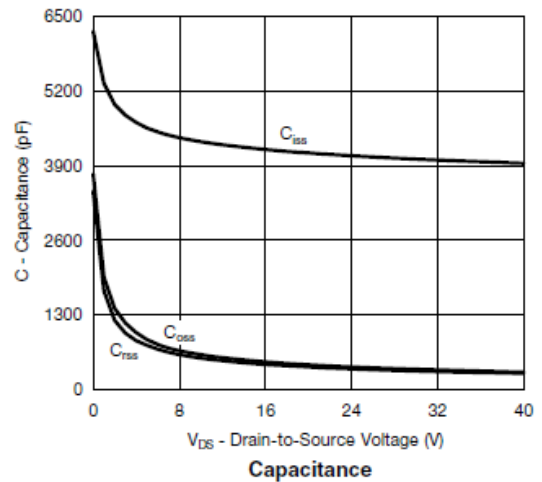
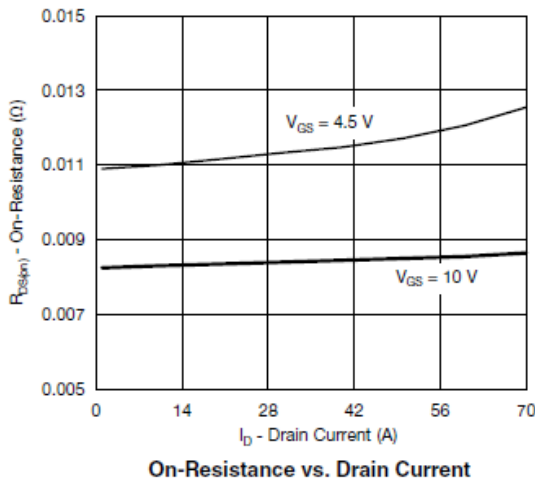
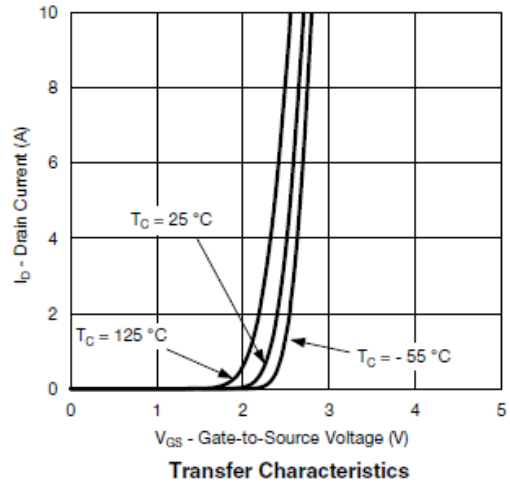
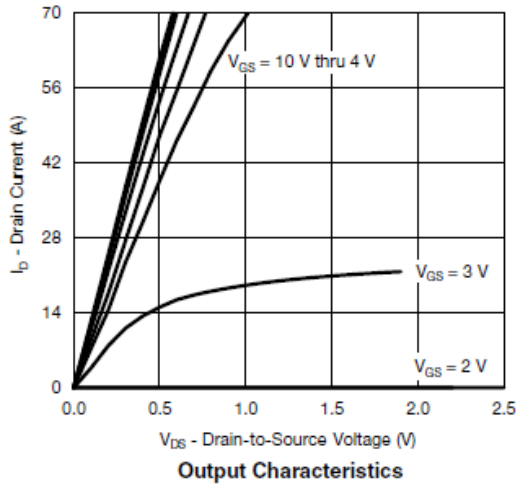



Typical Characteristics

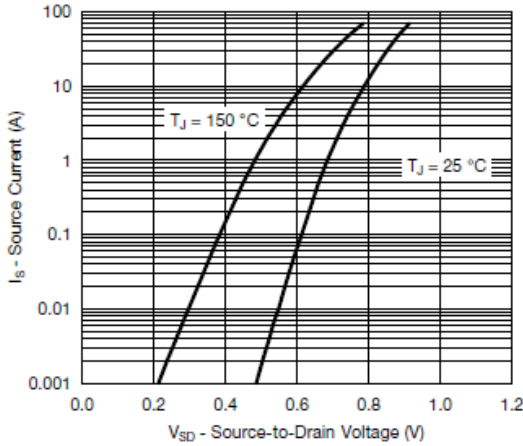

Source-Drain Diode Forward Voltage

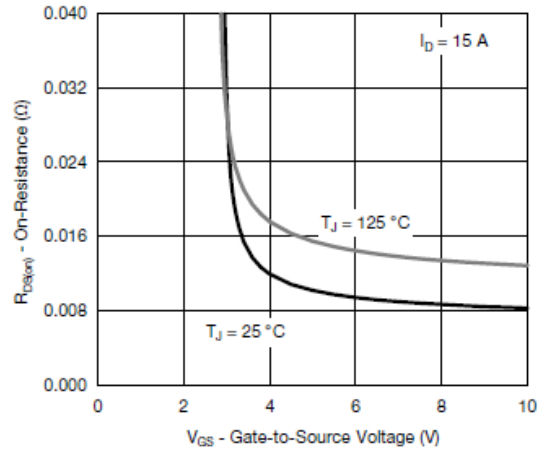

On-Resistance vs. Gate-to-Source Voltage

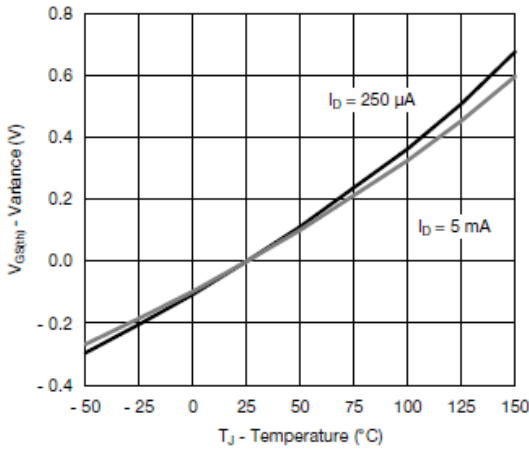

Threshold Voltage

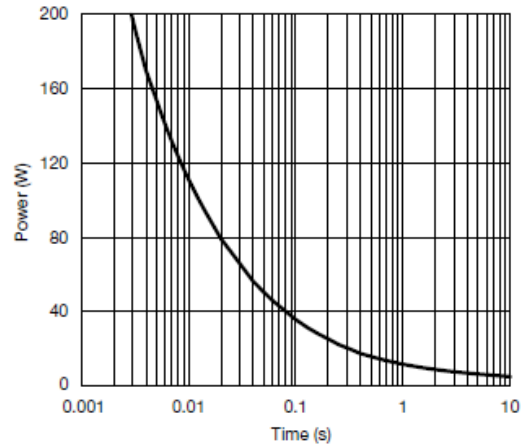

Single Pulse Power, Junction-to-Ambient

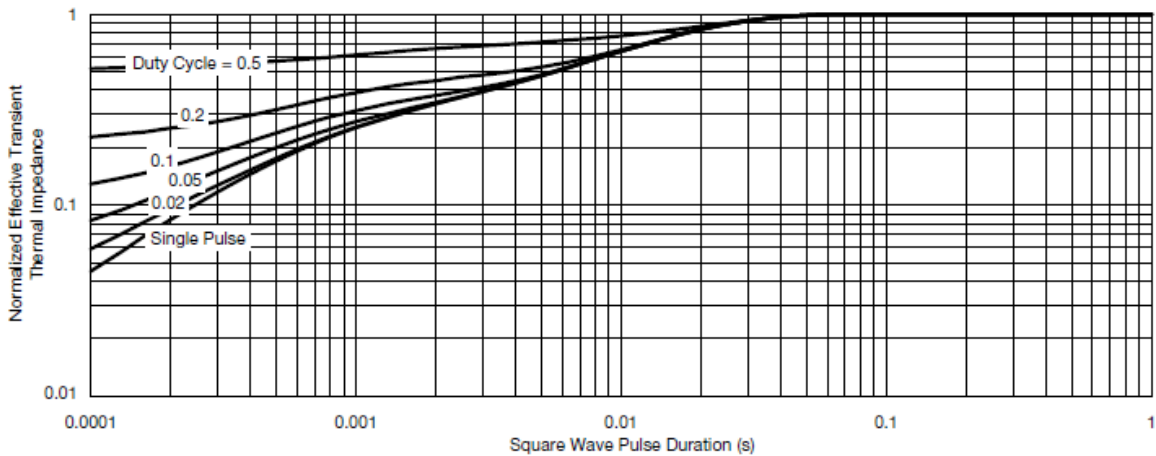

Normalized Thermal Transient Impedance, Junction-to-Case



Typical Characteristics

Gate Charge Test Circuit & Waveform

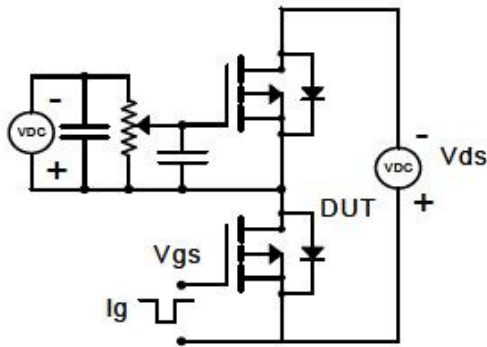

Resistive Switching Test Circuit & Waveforms

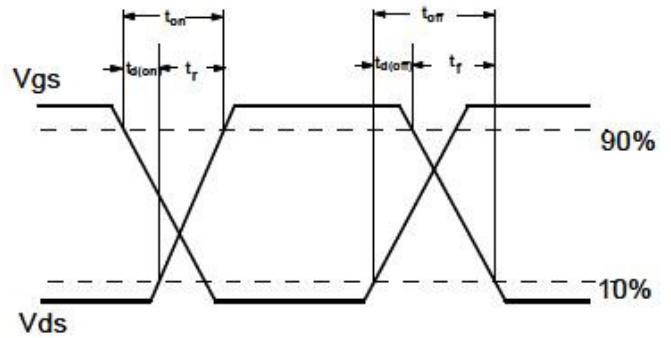
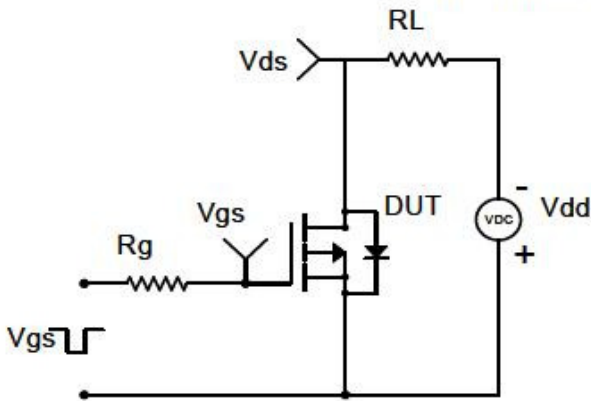

Diode Recovery Test Circuit & Waveforms

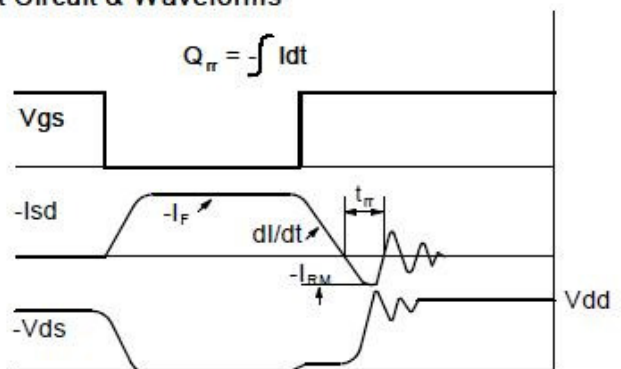
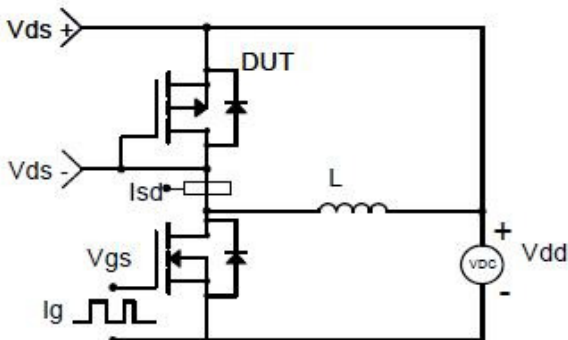



Package Information (DFN 5X6-8L)

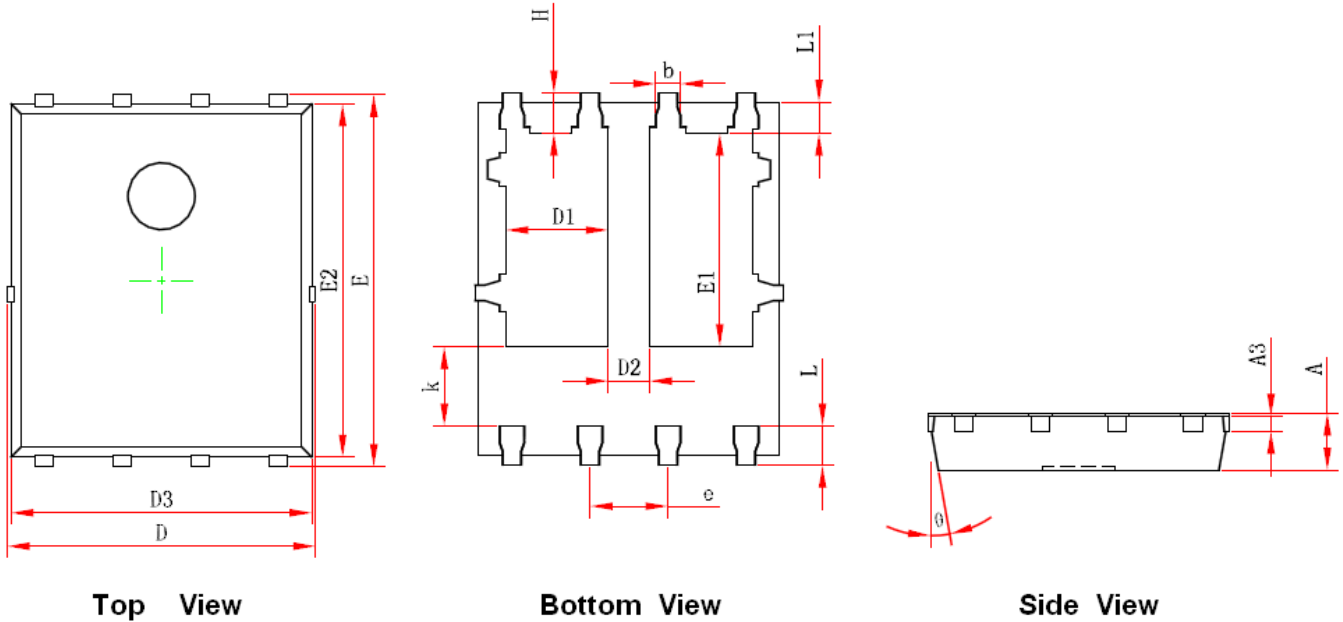

Symbol	Dimensions In Millimeters		Dimensions In Inches	
	Min.	Max.	Min.	Max.
A	0.900	1.000	0.035	0.039
A3	0.254 REF.		0.010REF.	
D	4.944	5.096	0.195	0.201
E	5.974	6.126	0.235	0.241
D1	1.470	1.870	0.058	0.074
D2	0.470	0.870	0.019	0.034
E1	3.375	3.575	0.133	0.141
D3	4.824	4.976	0.190	0.196
E2	5.674	5.826	0.223	0.229
k	1.190	1.390	0.047	0.055
b	0.350	0.450	0.014	0.018
e	1.270TYP.		0.050TYP.	
L	0.559	0.711	0.022	0.028
L1	0.424	0.576	0.017	0.023
H	0.574	0.726	0.023	0.029
θ	10°	12°	10°	12°

©2010 Alfa-MOS Technology Corp.
 2F, No.80, Sec.1, Cheng Kung Rd., Nan Kang Dist., Taipei City 115, Taiwan (R.O.C.)
 Tel : 886 2) 2651 3928
 Fax : 886 2) 2786 8483
 ©http://www.alfa-mos.com